

MATLAB®

Data Import and Export



MATLAB®

R2022b



How to Contact MathWorks



Latest news: www.mathworks.com
Sales and services: www.mathworks.com/sales_and_services
User community: www.mathworks.com/matlabcentral
Technical support: www.mathworks.com/support/contact_us



Phone: 508-647-7000



The MathWorks, Inc.
1 Apple Hill Drive
Natick, MA 01760-2098

MATLAB® Data Import and Export

© COPYRIGHT 2009–2022 by The MathWorks, Inc.

The software described in this document is furnished under a license agreement. The software may be used or copied only under the terms of the license agreement. No part of this manual may be photocopied or reproduced in any form without prior written consent from The MathWorks, Inc.

FEDERAL ACQUISITION: This provision applies to all acquisitions of the Program and Documentation by, for, or through the federal government of the United States. By accepting delivery of the Program or Documentation, the government hereby agrees that this software or documentation qualifies as commercial computer software or commercial computer software documentation as such terms are used or defined in FAR 12.212, DFARS Part 227.72, and DFARS 252.227-7014. Accordingly, the terms and conditions of this Agreement and only those rights specified in this Agreement, shall pertain to and govern the use, modification, reproduction, release, performance, display, and disclosure of the Program and Documentation by the federal government (or other entity acquiring for or through the federal government) and shall supersede any conflicting contractual terms or conditions. If this License fails to meet the government's needs or is inconsistent in any respect with federal procurement law, the government agrees to return the Program and Documentation, unused, to The MathWorks, Inc.

Trademarks

MATLAB and Simulink are registered trademarks of The MathWorks, Inc. See www.mathworks.com/trademarks for a list of additional trademarks. Other product or brand names may be trademarks or registered trademarks of their respective holders.

Patents

MathWorks products are protected by one or more U.S. patents. Please see www.mathworks.com/patents for more information.

Revision History

September 2009	Online only	New for MATLAB 7.9 (Release 2009b)
March 2010	Online only	Revised for MATLAB 7.10 (Release 2010a)
September 2010	Online only	Revised for MATLAB 7.11 (Release 2010b)
April 2011	Online only	Revised for MATLAB 7.12 (Release 2011a)
September 2011	Online only	Revised for MATLAB 7.13 (Release 2011b)
March 2012	Online only	Revised for MATLAB 7.14 (Release 2012a)
September 2012	Online only	Revised for MATLAB 8.0 (Release 2012b)
March 2013	Online only	Revised for MATLAB 8.1 (Release 2013a)
September 2013	Online only	Revised for MATLAB 8.2 (Release 2013b)
March 2014	Online only	Revised for MATLAB 8.3 (Release 2014a)
October 2014	Online only	Revised for MATLAB 8.4 (Release 2014b)
March 2015	Online only	Revised for MATLAB 8.5 (Release 2015a)
September 2015	Online only	Revised for MATLAB 8.6 (Release 2015b)
October 2015	Online only	Rereleased for MATLAB 8.5.1 (Release 2015aSP1)
March 2016	Online only	Revised for MATLAB 9.0 (Release 2016a)
September 2016	Online only	Revised for MATLAB 9.1 (Release 2016b)
March 2017	Online only	Revised for MATLAB 9.2 (Release 2017a)
September 2017	Online only	Revised for MATLAB 9.3 (Release 2017b)
March 2018	Online only	Revised for MATLAB 9.4 (Release 2018a)
September 2018	Online only	Revised for MATLAB 9.5 (Release 2018b)
March 2019	Online only	Revised for MATLAB 9.6 (Release 2019a)
September 2019	Online only	Revised for MATLAB 9.7 (Release 2019b)
March 2020	Online only	Revised for MATLAB 9.8 (Release 2020a)
September 2020	Online only	Revised for MATLAB 9.9 (Release 2020b)
March 2021	Online only	Revised for MATLAB 9.10 (Release 2021a)
September 2021	Online only	Revised for MATLAB 9.11 (Release 2021b)
March 2022	Online only	Revised for MATLAB 9.12 (Release 2022a)
September 2022	Online only	Revised for MATLAB 9.13 (Release 2022b)

1

File Opening, Loading, and Saving

Supported File Formats for Import and Export	1-2
Importing Files Programmatically	1-2
Workflows for Specialized Data Formats	1-5
Import Images, Audio, and Video Interactively	1-7
Viewing the Contents of a File	1-7
Specifying Variables	1-7
Generating Reusable MATLAB Code	1-9
Import or Export a Sequence of Files	1-10
MATLAB Example Data Sets	1-11
Observational Data	1-11
Image Data	1-12
Geographic Data	1-15
Video and Audio Data	1-16
Save and Load Parts of Variables in MAT-Files	1-18
Save and Load Using the matfile Function	1-18
Load Parts of Variables Dynamically	1-19
Avoid Inadvertently Loading Entire Variables	1-20
Partial Loading and Saving Requires Version 7.3 MAT-Files	1-20
MAT-File Versions	1-22
Overview of MAT-File Versions	1-22
Save to Nondefault MAT-File Version	1-23
Data Compression	1-23
Accelerate Save and Load Operations for Version 7.3 MAT-Files	1-24
Growing Arrays Using matfile Function	1-25
Unexpected Results When Loading Variables Within a Function	1-27
Create Temporary Files	1-29

Text Files

2

Import Text Files	2-2
Import Data as Tables	2-2
Import Data as Timetables	2-2

Import Data as Matrices	2-3
Import Data as Cell Arrays	2-3
Import Data as String Arrays	2-4
Import Data with Import Options for Additional Control	2-4
Import Data Interactively	2-4
Read Text File Data Using Import Tool	2-6
Select Data Interactively	2-6
Import Data from Multiple Text Files	2-8
Import Dates and Times from Text Files	2-10
Import Numeric Data from Text Files into Matrix	2-14
Import Comma-Separated Data	2-14
Import Delimited Numeric Data	2-14
Import Mixed Data from Text File into Table	2-16
Import Block of Mixed Data from Text File into Table or Cell Array	2-19
Write Data to Text Files	2-22
Export Table to Text File	2-22
Export Cell Array to Text File	2-23
Export Numeric Array to Text File	2-24
Write to a Diary File	2-26
Read Collection or Sequence of Text Files	2-27
Import Block of Numeric Data from Text File	2-30

Spreadsheets

3

Import Spreadsheets	3-2
Import Spreadsheet Data Using the Import Tool	3-2
Import Spreadsheet Data Using readtable	3-2
Import Spreadsheet Data as Other Data Types	3-3
Read Spreadsheet Data Using Import Tool	3-4
Select Data Interactively	3-4
Import Data from Multiple Spreadsheets	3-5
Paste Data from Clipboard	3-6
Read Spreadsheet Data into Array or Individual Variables	3-7
Read Spreadsheet Data into Table	3-9
Read Collection or Sequence of Spreadsheet Files	3-12

Write Data to Excel Spreadsheets	3-15
Write Tabular Data to Spreadsheet File	3-15
Write Numeric and Text Data to Spreadsheet File	3-15
Disable Warning When Adding New Worksheet	3-16
Format Cells in Excel Files	3-16
Define Import Options for Tables	3-18

Low-Level File I/O

4

Import Text Data Files with Low-Level I/O	4-2
Overview	4-2
Reading Data in a Formatted Pattern	4-2
Reading Data Line-by-Line	4-4
Testing for End of File (EOF)	4-5
Opening Files with Different Character Encodings	4-7
Import Binary Data with Low-Level I/O	4-8
Low-Level Functions for Importing Data	4-8
Reading Binary Data in a File	4-8
Reading Portions of a File	4-10
Reading Files Created on Other Systems	4-12
Export to Text Data Files with Low-Level I/O	4-13
Write to Text Files Using fprintf	4-13
Append to or Overwrite Existing Text Files	4-14
Open Files with Different Character Encodings	4-17
Export Binary Data with Low-Level I/O	4-18
Low-Level Functions for Exporting Data	4-18
Write Binary Data to a File	4-18
Overwrite or Append to an Existing Binary File	4-19
Create a File for Use on a Different System	4-20
Write and Read Complex Numbers	4-21

Internet of Things (IoT) Data

5

Aggregate Data in ThingSpeak Channel	5-2
Regularize Irregularly Sampled Data	5-3
Plot Data Read from ThingSpeak Channel	5-4
Read ThingSpeak Data and Predict Battery Discharge Time with Linear Fit	5-6

6

Importing Images	6-2
Getting Information About Image Files	6-2
Reading Image Data and Metadata from TIFF Files	6-3
Exporting to Images	6-5
Exporting Image Data and Metadata to TIFF Files	6-5

Scientific Data

7

Import CDF Files Using Low-Level Functions	7-2
Represent CDF Time Values	7-4
Import CDF Files Using High-Level Functions	7-5
Export to CDF Files	7-8
Map NetCDF API Syntax to MATLAB Syntax	7-11
Import NetCDF Files and OPeNDAP Data	7-13
MATLAB NetCDF Capabilities	7-13
Security Considerations When Connecting to an OPeNDAP Server	7-13
Read from NetCDF File Using High-Level Functions	7-13
Find All Unlimited Dimensions in NetCDF File	7-15
Read from NetCDF File Using Low-Level Functions	7-16
Resolve Errors Reading OPeNDAP Data	7-20
Export to NetCDF Files	7-21
MATLAB NetCDF Capabilities	7-21
Create New NetCDF File from Existing File or Template	7-21
Merge Two NetCDF Files	7-22
Write Data to NetCDF File Using Low-Level Functions	7-24
Importing Flexible Image Transport System (FITS) Files	7-27
Import HDF5 Files	7-28
Overview	7-28
Import Data Using High-Level HDF5 Functions	7-28
Import Data Using Low-Level HDF5 Functions	7-33
Read HDF5 Data Set Using Dynamically Loaded Filters	7-33
Export to HDF5 Files	7-34
Overview	7-34
Export Data Using MATLAB High-Level HDF5 Functions	7-34
Export Data Using MATLAB Low-Level HDF5 Functions	7-35
Write HDF5 Data Set Using Dynamically Loaded Filters	7-40

Work with Non-ASCII Characters in HDF5 Files	7-41
Create Data Set and Attribute Names Containing Non-ASCII Characters	7-41
Create Variable-Length String Data Containing Non-ASCII Characters ..	7-42
Import HDF4 Files Programmatically	7-44
Overview	7-44
Using the MATLAB HDF4 High-Level Functions	7-44
Read and Write Data Concurrently Using Single-Writer/Multiple-Reader (SWMR)	7-47
Overview	7-47
Requirements and Limitations	7-47
Enable SWMR Access for HDF5 File	7-47
Write to HDF5 File While Two Processes Read	7-48
Work with HDF5 Virtual Datasets (VDS)	7-52
Overview	7-52
Create a Virtual Dataset	7-52
Work with Remotely Stored Virtual Datasets	7-52
Create Virtual Dataset from Datasets of Varying Sizes	7-53
Read and Write HDF5 Datasets Using Dynamically Loaded Filters	7-59
Install Filter Plugins	7-59
Read Datasets Compressed with Third-Party Filters	7-60
Write Datasets Compressed with Third-Party Filters	7-60
Map HDF4 to MATLAB Syntax	7-64
Import HDF4 Files Using Low-Level Functions	7-65
About HDF4 and HDF-EOS	7-68
Export to HDF4 Files	7-69
Write MATLAB Data to HDF4 File	7-69
Manage HDF4 Identifiers	7-70

Audio and Video

8

Read and Write Audio Files	8-2
Record and Play Audio	8-4
Record Audio	8-4
Play Audio	8-6
Record or Play Audio within a Function	8-6
Read Video Files	8-8
Supported Video and Audio File Formats	8-12
Video Data in MATLAB	8-12
Audio Data in MATLAB	8-14

Convert Between Image Sequences and Video	8-16
--	-------------

XML Documents

9

Import an XML File into a Document Object Model	9-2
The XML Document Object Model	9-2
Read an XML File Using the MAXP Parser	9-3
Read an XML File Using xmlread	9-4
Export a Document Object Model to an XML File	9-6
Create a DOM Document	9-6
Write a DOM Document Node to an XML File Using a MAXP DOMWriter Object	9-6
Write a DOM Document Node to an XML File Using xmlwrite	9-8
Update an Existing XML File	9-8

Memory-Mapping Data Files

10

Overview of Memory-Mapping	10-2
What Is Memory-Mapping?	10-2
Benefits of Memory-Mapping	10-2
When to Use Memory-Mapping	10-3
Maximum Size of a Memory Map	10-4
Byte Ordering	10-4
Map File to Memory	10-5
Create a Simple Memory Map	10-5
Specify Format of Your Mapped Data	10-6
Map Multiple Data Types and Arrays	10-6
Select File to Map	10-8
Read from Mapped File	10-9
Write to Mapped File	10-14
Write to Memory Mapped as Numeric Array	10-14
Write to Memory Mapped as Scalar Structure	10-15
Write to Memory Mapped as Nonscalar Structure	10-15
Syntaxes for Writing to Mapped File	10-16
Work with Copies of Your Mapped Data	10-17
Delete Memory Map	10-19
Ways to Delete a Memory Map	10-19
The Effect of Shared Data Copies On Performance	10-19
Share Memory Between Applications	10-20

Server Authentication	11-2
Server Authentication For RESTful Web Services	11-2
Server Authentication For HTTP Web Services	11-2
Proxy Server Authentication	11-4
RESTful Web Services	11-4
HTTP Web Services	11-4
Use MATLAB Web Preferences For Proxy Server Settings	11-4
Use System Settings For Proxy Server Settings	11-5
MATLAB and Web Services Security	11-6
MATLAB Does Not Verify Certificate Chains	11-6
Download Data from Web Service	11-7
Convert Data from Web Service	11-10
Download Web Page and Files	11-13
Example — Use the webread Function	11-13
Example — Use the websave Function	11-13
Call Web Services from Functions	11-14
Error Messages Concerning Web Service Options	11-15
Send Email	11-16
Perform FTP File Operations	11-17
Display Hyperlinks in the Command Window	11-19
Create Hyperlinks to Web Pages	11-19
Transfer Files Using FTP	11-19
Customize JSON Encoding for MATLAB Classes	11-20

Serial Port Overview	12-2
What Is Serial Communication?	12-2
Serial Port Interface Standard	12-2
Supported Platforms	12-3
Connecting Two Devices with a Serial Cable	12-3
Serial Port Signals and Pin Assignments	12-3
Serial Data Format	12-6
Find Serial Port Information for Your Platform	12-9
Create Serial Port Object	12-13
Create a Serial Port Object	12-13

Serial Port Object Display	12-13
Configure Serial Port Communication Settings	12-15
Write and Read Serial Port Data	12-17
Rules for Completing Write and Read Operations	12-17
Writing and Reading Text Data	12-17
Writing and Reading Binary Data	12-19
Use Callbacks for Serial Port Communication	12-21
Callback Properties	12-21
Using Callbacks	12-21
Use Serial Port Control Pins	12-22
Control Pins	12-22
Signaling the Presence of Connected Devices	12-22
Controlling the Flow of Data: Handshaking	12-24
Transition Your Code to serialport Interface	12-26
Removed Functionality	12-26
Discover Serial Port Devices	12-27
Connect to Serial Port Device	12-27
Read and Write	12-27
Send a Command	12-28
Read a Terminated String	12-28
Flush Data from Memory	12-29
Set Terminator	12-30
Set Up a Callback Function	12-30
Read Serial Pin Status	12-30
Set Serial DTR and RTS Pin States	12-31
Read Streaming Data from Arduino Using Serial Port Communication	12-32
Troubleshooting Serial Port Interface	12-35
Issue	12-35
Possible Solutions	12-35
Resolve Serial Port Connection Errors	12-38
Issue	12-38
Possible Solutions	12-38
Serialport Warning - Unable to Read All Data	12-40
Serialport Warning - Unable to Read Any Data	12-41

Large Data

13

Getting Started with MapReduce	13-3
What Is MapReduce?	13-3
MapReduce Algorithm Phases	13-3

Example MapReduce Calculation	13-4
Write a Map Function	13-9
Role of Map Function in MapReduce	13-9
Requirements for Map Function	13-10
Sample Map Functions	13-10
Write a Reduce Function	13-13
Role of the Reduce Function in MapReduce	13-13
Requirements for Reduce Function	13-14
Sample Reduce Functions	13-14
Speed Up and Deploy MapReduce Using Other Products	13-17
Execution Environment	13-17
Running in Parallel	13-17
Application Deployment	13-17
Build Effective Algorithms with MapReduce	13-18
Debug MapReduce Algorithms	13-20
Set Breakpoint	13-20
Execute mapreduce	13-20
Step Through Map Function	13-21
Step Through Reduce Function	13-22
Analyze Big Data in MATLAB Using MapReduce	13-25
Find Maximum Value with MapReduce	13-33
Compute Mean Value with MapReduce	13-36
Compute Mean by Group Using MapReduce	13-39
Create Histograms Using MapReduce	13-44
Simple Data Subsetting Using MapReduce	13-51
Using MapReduce to Compute Covariance and Related Quantities ...	13-57
Compute Summary Statistics by Group Using MapReduce	13-62
Using MapReduce to Fit a Logistic Regression Model	13-69
Tall Skinny QR (TSQR) Matrix Factorization Using MapReduce	13-75
Compute Maximum Average HSV of Images with MapReduce	13-80
Getting Started with Datastore	13-86
What Is a Datastore?	13-86
Create and Read from a Datastore	13-87
Select Datastore for File Format or Application	13-90
Datastores for Standard File Formats	13-90
Datastores for Specific Applications	13-90

Custom File Formats	13-92
Nondeterministic Datastores	13-92
Work with Remote Data	13-93
Amazon S3	13-93
Azure Blob Storage	13-94
Hadoop Distributed File System	13-96
Read and Analyze Large Tabular Text File	13-98
Read and Analyze Image Files	13-100
Read and Analyze MAT-File with Key-Value Data	13-104
Read and Analyze Hadoop Sequence File	13-107
Develop Custom Datastore	13-109
Overview	13-109
Implement Datastore for Serial Processing	13-110
Add Support for Parallel Processing	13-112
Add Support for Hadoop	13-113
Add Support for Shuffling	13-114
Add Support for Writing Data	13-115
Validate Custom Datastore	13-117
Testing Guidelines for Custom Datastores	13-118
Unit Tests	13-118
Workflow Tests	13-124
Next Steps	13-125
Develop Custom Datastore for DICOM Data	13-126
Developing Custom Datastores	13-126
Class Definition	13-126
Using the DICOMDatastore Class	13-130
Set Up Datastore for Processing on Different Machines or Clusters .	13-132
Save Datastore and Load on Different File System Platform	13-132
Process Datastore Using Parallel and Distributed Computing	13-133
Apache Parquet Data Type Mappings	13-135
Numeric Data Types	13-135
Binary Data Types	13-138
Date and Time Data Types	13-140
Nested Data	13-143
Tall Arrays for Out-of-Memory Data	13-146
What is a Tall Array?	13-146
Benefits of Tall Arrays	13-146
Creating Tall Tables	13-146
Creating Tall Timetables	13-147
Creating Tall Arrays	13-148
Deferred Evaluation	13-148
Evaluation with gather	13-149
Saving, Loading, and Checkpointing Tall Arrays	13-150
Supporting Functions	13-151

Deferred Evaluation of Tall Arrays	13-152
Display of Unevaluated Tall Arrays	13-152
Evaluation with gather	13-153
Resolve Errors with gather	13-153
Example: Calculate Size of Tall Array	13-153
Example: Multi-pass Calculations with Tall Arrays	13-154
Summary of Behavior and Recommendations	13-156
Index and View Tall Array Elements	13-157
Extract Top Rows of Array	13-157
Extract Bottom Rows of Array	13-157
Indexing Tall Arrays	13-158
Extract Tall Table Variables	13-160
Concatenation with Tall Arrays	13-161
Assignment and Deletion with Tall Arrays	13-162
Extract Specified Number of Rows in Sorted Order	13-162
Summarize Tall Array Contents	13-163
Return Subset of Calculation Results	13-164
Histograms of Tall Arrays	13-166
Visualization of Tall Arrays	13-171
Tall Array Plotting Examples	13-172
Grouped Statistics Calculations with Tall Arrays	13-179
Extend Tall Arrays with Other Products	13-185
Statistics and Machine Learning	13-185
Control Where Your Code Runs	13-185
Work with Databases	13-186
Analyze Big Data in MATLAB Using Tall Arrays	13-187
Develop Custom Tall Array Algorithms	13-196
Reasons to Implement Custom Algorithms	13-196
Supported APIs	13-196
Background: Tall Array Blocks	13-197
Single-Step Transformation Operation	13-198
Two-Step Reduction Operation	13-200
Sliding-Window Operations	13-203
Control Output Data Type	13-208
Coding and Performance Tips	13-208

TCP/IP Support in MATLAB

14

TCP/IP Communication Overview	14-2
Create TCP/IP Client and Configure Settings	14-3
Create Object Using Host Name	14-3
Create Object Using IP Address	14-3
Set Timeout Property	14-4

Set Connect Timeout Property	14-4
Set Transfer Delay Property	14-5
View TCP/IP Object Properties	14-5
Write and Read Data over TCP/IP Interface	14-7
Write Data	14-7
Read Data	14-7
Acquire Data from Weather Station Server	14-8
Read Page from Website	14-8
Use Callbacks for TCP/IP Communication	14-10
Configure Connection in TCP/IP Explorer	14-11
Communicate Binary and ASCII Data to an Echo Server Using TCP/IP	14-12
Troubleshooting TCP/IP Client Interface	14-15
Issue	14-15
Possible Solutions	14-15
Resolve TCP/IP Client Connection Errors	14-17
Issue	14-17
Possible Solutions	14-17
Resolve TCP/IP Client Warning: Unable to Read Any Data	14-19
Issue	14-19
Possible Solutions	14-19

Bluetooth Low Energy Communication

15

Bluetooth Low Energy Communication Overview	15-2
Prerequisites and Setup	15-2
Bluetooth Low Energy Concepts	15-2
Services, Characteristics, and Descriptors	15-3
Find Your Bluetooth Low Energy Peripheral Devices	15-4
Scan for Devices	15-4
Connect to a Device	15-5
Work with Device Characteristics and Descriptors	15-7
Access Device Characteristics	15-7
Access Device Descriptors	15-10
Collect Data from Fitness Monitoring Devices	15-12
Track Orientation of Bluetooth Low Energy Device	15-18
Troubleshooting Bluetooth Low Energy	15-23
Issue	15-23
Possible Solutions	15-23

Bluetooth Communication Overview	16-2
Bluetooth Communication	16-2
Supported Platforms	16-2
Configure Bluetooth Communication Settings	16-3
Discover Your Device	16-3
Connect to Your Device and View Properties	16-4
Transmit Data Using Bluetooth Communication	16-6
Use Callbacks for Bluetooth Communication	16-8
Callback Properties	16-8
Using Callbacks	16-8
Troubleshooting Bluetooth Communication	16-10
Issue	16-10
Possible Solutions	16-10
Resolve Bluetooth Connection Errors	16-12
Issue	16-12
Possible Solutions	16-12
Resolve Bluetooth Warning: Unable to Read Any Data	16-14
Issue	16-14
Possible Solutions	16-14
Resolve Bluetooth Warning: Unable to Read All Data	16-15
Issue	16-15
Possible Solutions	16-15
Communicate with HC-06 over Bluetooth	16-16
Transition Your Code to bluetooth Interface	16-19
Removed Functionality	16-19
Discover Bluetooth Devices	16-20
Connect to Bluetooth Device	16-20
Write and Read	16-20
Read Terminated String	16-21
Send Command	16-22
Write and Read Back Data	16-23
Read and Parse String Data	16-23
Flush Data from Memory	16-23
Set Terminator	16-24
Set Up Callback Function	16-24

Get Started with Hardware Manager	17-2
Discover Hardware	17-2
Add Hardware	17-4

File Opening, Loading, and Saving

- “Supported File Formats for Import and Export” on page 1-2
- “Import Images, Audio, and Video Interactively” on page 1-7
- “Import or Export a Sequence of Files” on page 1-10
- “MATLAB Example Data Sets” on page 1-11
- “Save and Load Parts of Variables in MAT-Files” on page 1-18
- “MAT-File Versions” on page 1-22
- “Growing Arrays Using matfile Function” on page 1-25
- “Unexpected Results When Loading Variables Within a Function” on page 1-27
- “Create Temporary Files” on page 1-29

Supported File Formats for Import and Export

In this section...

“Importing Files Programmatically” on page 1-2

“Workflows for Specialized Data Formats” on page 1-5

The ideal workflow to import data into MATLAB depends on how your data is formatted as well as your personal preferences. You can import data programmatically or use a specialized workflow. The most common solution is to import data programmatically using a function tailored for your data.

When you import data into the MATLAB workspace, the new variables you create overwrite any existing variables in the workspace that have the same name.

Importing Files Programmatically

MATLAB includes functions tailored to import specific file formats. Consider using format-specific functions when you want to import an entire file or only a portion of a file. Many of the format-specific functions provide options for selecting ranges or portions of data. Some format-specific functions allow you to request multiple optional outputs.

This table shows the file formats that you can import and export from the MATLAB application.

File Content	Extension	Description	Import Function	Export Function
MATLAB formatted data	MAT	Saved MATLAB workspace	load	save
		Partial access of variables in MATLAB workspace	matfile	matfile
Text	any, including: CSV TXT	Delimited numbers	readmatrix	writematrix
		Delimited numbers, or a mix of text and numbers	textscan	none
		Column-oriented delimited numbers or a mix of text and numbers	readtable readcell readvars	writetable writecell
		Plain text	readlines	writelines

File Content	Extension	Description	Import Function	Export Function
Spreadsheet	XLS XLSX XLSM XLSB (Systems with Microsoft® Excel® for Windows® only) XLTM (import only) XLTX (import only) ODS (Systems with Microsoft Excel for Windows only)	Column-oriented data in worksheet or range of spreadsheet	readmatrix readtable readcell readvars	writematrix writetable writecell
Extensible Markup Language	XML	XML-formatted text	readstruct readtable readtimetable	writestruct writetable writetimetable
Parquet formatted data	PARQUET	Column-oriented data in Parquet format	parquetread	parquetwrite
Data Acquisition Toolbox™ file	DAQ	Data Acquisition Toolbox	daqread	none
Scientific data	CDF	Common Data Format	See “Common Data Format”	See cdflib
	FITS	Flexible Image Transport System	See “FITS Files”	See “FITS Files”
	HDF	HDF4 or HDF-EOS2	See “HDF4 Files”	See “HDF4 Files”
	H5	HDF5	See “HDF5 Files”	See “HDF5 Files”
	NC	Network Common Data Form (netCDF)	See “NetCDF Files”	See “NetCDF Files”
Image data	BMP	Windows Bitmap	imread	imwrite
	GIF	Graphics Interchange Format		
	HDF	Hierarchical Data Format		
	JPEG JPG	Joint Photographic Experts Group		
	JP2 JPF JPX J2C J2K	JPEG 2000		

File Content	Extension	Description	Import Function	Export Function
	PBM	Portable Bitmap		
	PCX	Paintbrush		
	PGM	Portable Graymap		
	PNG	Portable Network Graphics		
	PNM	Portable Any Map		
	PPM	Portable Pixmap		
	RAS	Sun™ Raster		
	TIFF TIF	Tagged Image File Format		
	XWD	X Window Dump		
	CUR	Windows cursor resources		
	ICO	Windows icon resources		
Audio (all platforms)	AU SND	NeXT/Sun sound	audioread	audiowrite
	AIFF	Audio Interchange File Format		
	AIFC	Audio Interchange File Format, with compression codecs		
	FLAC	Free Lossless Audio Codec		
	OGG	Ogg Vorbis		
	OPUS	Ogg Opus		
	WAV	Microsoft WAVE sound		
Audio (Windows)	M4A MP4	MPEG-4	audioread	audiowrite
	any	Formats supported by Microsoft Media Foundation	audioread	none
Audio (Mac)	M4A MP4	MPEG-4	audioread	audiowrite
Audio (Linux®)	any	Formats supported by GStreamer	audioread	none
Video (all platforms)	AVI	Audio Video Interleave	VideoReader	VideoWriter
	MJ2	Motion JPEG 2000		
Video (Windows)	MPG	MPEG-1	VideoReader	none
	ASF ASX WMV	Windows Media®		
	any	Formats supported by Microsoft DirectShow®		

File Content	Extension	Description	Import Function	Export Function
Video (Windows 7 or later)	MP4 M4V	MPEG-4	VideoReader	VideoWriter
	MOV	QuickTime	VideoReader	none
	any	Formats supported by Microsoft Media Foundation		
Video (Mac)	MP4 M4V	MPEG-4	VideoReader	VideoWriter
	MPG	MPEG-1	VideoReader	none
	MOV	QuickTime		
	any	Formats supported by QuickTime, including .3gp, .3g2, and .dv		
Video (Linux)	any	Formats supported by your installed GStreamer plug-ins, including .ogg	VideoReader	none
Triangulation	STL	Stereolithography	stlread	stlwrite
Low-level files	any text format	Low-level binary text data	fread	fwrite
	any	Low-level binary	fscanf	fprintf
	any text format	Formatted data from a text file or string	textscan	none

Workflows for Specialized Data Formats

Memory-Mapping for Binary Data

For binary data files, consider the “Overview of Memory-Mapping” on page 10-2. Memory-mapping enables you to access file data using standard MATLAB indexing operations. Memory-mapping is a mechanism that maps a portion of a file, or an entire file, on disk to a range of addresses within an application's address space. The application can then access files on disk in the same way it accesses dynamic memory. The principal benefits of memory-mapping are efficiency, faster file access, the ability to share memory between applications, and more efficient coding.

Specialized Importing with MATLAB Toolboxes

MATLAB toolboxes perform specialized import operations. For example, use Database Toolbox™ software for importing data from relational databases. Refer to the documentation on specific toolboxes to see the available import features.

Web Services for Reading and Writing Data

You can use web services such as a RESTful or WSDL to read and write data in an internet media type format such as JSON, XML, image, or text. For more information, see:

- “Web Services”
- “Use WSDL with MATLAB”

Reading Data with Low-Level IO

If the format-specific functions cannot read your data and the specialized workflows do not fit your needs, use *low-level I/O functions* such as `fscanf` or `fread`. Low-level functions allow the most control over reading from a file, but they require detailed knowledge of the structure of your data. This workflow is not commonly used.

See Also

Related Examples

- “Standard File Formats”

Import Images, Audio, and Video Interactively

Import data interactively into MATLAB workspace.

In this section...

“Viewing the Contents of a File” on page 1-7

“Specifying Variables” on page 1-7

“Generating Reusable MATLAB Code” on page 1-9

Note For information on importing text files, see “Read Text File Data Using Import Tool” on page 2-6. For information on importing spreadsheets, see “Read Spreadsheet Data Using Import Tool” on page 3-4.

Viewing the Contents of a File

Start the Import Wizard by clicking the **Import Data**  button or calling `uiimport`.

To view images or video, or to listen to audio, click the **< Back** button on the first window that the Import Wizard displays.

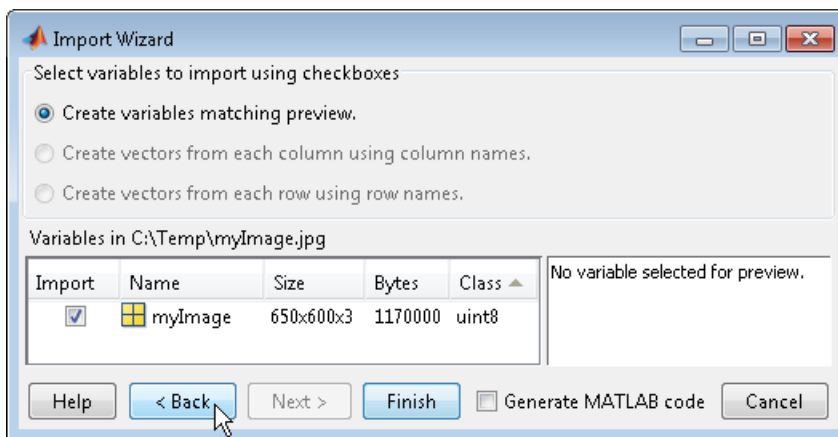

The right pane of the new window includes a preview tab. Click the button in the preview tab to show an image or to play audio or video.

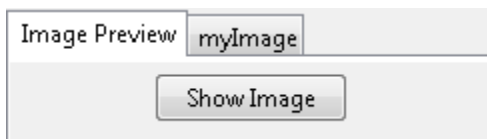

Specifying Variables

The Import Wizard generates default variable names based on the format and content of your data. You can change the variables in any of the following ways:

- “Renaming or Deselecting Variables” on page 1-8
- “Importing to a Structure Array” on page 1-8

The default variable name for data imported from the system clipboard is `A_pastespecial`.

If the Import Wizard detects a single variable in a file, the default variable name is the file name. Otherwise, the Import Wizard uses default variable names that correspond to the output fields of the `importdata` function. For more information on the output fields, see the `importdata` function reference page.

Renaming or Deselecting Variables

To override the default variable name, select the name and type a new one.

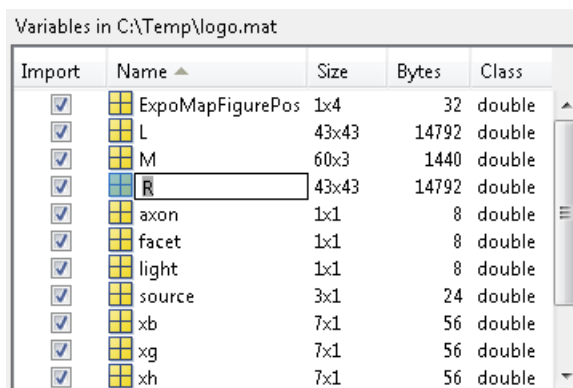

Import	Name	Size	Bytes	Class
<input checked="" type="checkbox"/>	ExpoMapFigurePos	1x4	32	double
<input checked="" type="checkbox"/>	L	43x43	14792	double
<input checked="" type="checkbox"/>	M	60x3	1440	double
<input checked="" type="checkbox"/>	R	43x43	14792	double
<input checked="" type="checkbox"/>	axon	1x1	8	double
<input checked="" type="checkbox"/>	facet	1x1	8	double
<input checked="" type="checkbox"/>	light	1x1	8	double
<input checked="" type="checkbox"/>	source	3x1	24	double
<input checked="" type="checkbox"/>	xb	7x1	56	double
<input checked="" type="checkbox"/>	xg	7x1	56	double
<input checked="" type="checkbox"/>	xh	7x1	56	double

To avoid importing a particular variable, clear the check box in the **Import** column.

Importing to a Structure Array

To import data into fields of a structure array rather than as individual variables, start the Import Wizard by calling `uiimport` with an output argument. For example, the sample file `durer.mat` contains three variables: `X`, `caption`, and `map`. If you issue the command

```
durerStruct = uiimport('durer.mat')
```

and click the **Finish** button, the Import Wizard returns a scalar structure with three fields:

```
durerStruct =  
    X: [648x509 double]  
   map: [128x3 double]  
 caption: [2x28 char]
```

To access a particular field, use dot notation. For example, view the `caption` field:

```
disp(durerStruct.caption)
```

MATLAB returns:

```
Albrecht Durer's Melancholia.  
Can you find the matrix?
```

For more information, see “Structure Arrays”.

Generating Reusable MATLAB Code

To create a function that reads similar files without restarting the Import Wizard, select the **Generate MATLAB code** check box. When you click **Finish** to complete the initial import operation, MATLAB opens an Editor window that contains an unsaved function. The default function name is `importfile.m` or `importfileN.m`, where *N* is an integer.

The function in the generated code includes the following features:

- For text files, if you request vectors from rows or columns, the generated code also returns vectors.
- When importing from files, the function includes an input argument for the name of the file to import, `fileToRead1`.
- When importing into a structure array, the function includes an output argument for the name of the structure, `newData1`.

However, the generated code has the following limitations:

- If you rename or deselect any variables in the Import Wizard, the generated code does not reflect those changes.
- If you do not import into a structure array, the generated function creates variables in the base workspace. If you plan to call the generated function from within your own function, your function cannot access these variables. To allow your function to access the data, start the Import Wizard by calling `uiimport` with an output argument. Call the generated function with an output argument to create a structure array in the workspace of your function.

MATLAB does not automatically save the function. To save the file, select **Save**. For best results, use the function name with a `.m` extension for the file name.

See Also

`imread` | `VideoReader` | `audioread`

More About

- “Read Video Files” on page 8-8
- “Read and Write Audio Files” on page 8-2
- “Importing Images” on page 6-2

Import or Export a Sequence of Files

To import or export multiple files, create a control loop to process one file at a time. When constructing the loop:

- To build sequential file names, use `sprintf`.
- To find files that match a pattern, use `dir`.
- Use *function syntax* to pass the name of the file to the import or export function. (For more information, see “Choose Command Syntax or Function Syntax”.)

For example, to read files named `file1.txt` through `file20.txt` with `importdata`:

```
numfiles = 20;
mydata = cell(1, numfiles);

for k = 1:numfiles
    myfilename = sprintf('file%d.txt', k);
    mydata{k} = importdata(myfilename);
end
```

To read all files that match `*.jpg` with `imread`:

```
jpegFiles = dir('*.jpg');
numfiles = length(jpegFiles);
mydata = cell(1, numfiles);

for k = 1:numfiles
    mydata{k} = imread(jpegFiles(k).name);
end
```

MATLAB Example Data Sets

MATLAB has hundreds of data sets included in the software installation spanning a variety of file formats and sizes. These data sets are used in documentation examples and to demo software capabilities. This topic summarizes useful data sets in a variety of formats, but it is not a comprehensive list.





Observational Data

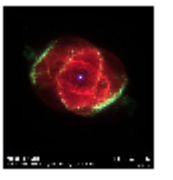

Filename	Description	How to Load
accidents.mat	Data on US traffic accidents and fatalities in 2004 from the US Department of Transportation. The data covers all 50 states and the District of Columbia. File Size: 8 KB Data Size: 51 rows, 17 variables	load <code>accidents.mat</code>
census.mat	US population data from 1790 - 1990. File Size: 1 KB Data Size: Two column vectors with 21 elements	load <code>census.mat</code>
airlinesmall.csv	US domestic airline flight data from 1987 - 2008. File Size: 11,747 KB Data Size: 123,523 rows, 29 variables	See “Analyze Big Data in MATLAB Using Tall Arrays” on page 13-187 for an example that loads and processes this data.
patients.mat	Medical patient information for 100 fictional patients. File Size: 3 KB Data Size: 100 rows, 10 variables	load <code>patients.mat</code>
outages.csv	Data on electric utility outages in the US. File Size: 99 KB Data Size: 1,468 rows, 6 variables	Load the CSV data as a table: <code>T = readtable('outages.csv');</code>

Filename	Description	How to Load
penny.mat	<p>A detailed 3-D image of the surface of a US penny.</p> <p>File Size: 2 KB</p> <p>Data Size: 128-by-128 matrix</p>	<p>To view a surface plot of the penny, use the command:</p> <pre>penny</pre> <p>For more information, read the script:</p> <pre>edit penny.m</pre>
seamount.mat	<p>A <i>seamount</i> is an underwater mountain. The data set consists of a set of longitude (x) and latitude (y) locations, and corresponding seamount elevations (z) measured at those coordinates.</p> <p>File Size: 2 KB</p> <p>Data Size: Three column vectors with 294 elements.</p>	<pre>load seamount.mat</pre>
wind.mat	<p>3-D data on air currents over North America. The data consists of (x, y, z) position components and (u, v, w) velocity components.</p> <p>File Size: 142 KB</p> <p>Data Size: Six matrices of size 35-by-41-by-15</p>	<pre>load wind.mat</pre>

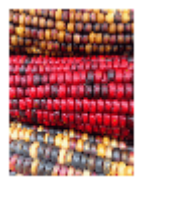
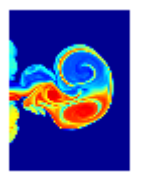

Image Data

Filename	Description	How to Load
ngc6543a.jpg 	<p>This NASA Hubble Space Telescope image shows one of the most complex planetary nebulae ever seen, NGC 6543, nicknamed the "Cat's Eye Nebula." Hubble reveals surprisingly intricate structures including concentric gas shells, jets of high-speed gas and unusual shock-induced knots of gas.</p> <p>File Size: 27 KB</p> <p>Image Size: 600 x 650</p>	<pre>I = imread('ngc6543a.jpg'); imshow(I)</pre>

Filename	Description	How to Load
street1.jpg 	A picture of a city street including cars, pedestrians, signs, and buildings. File Size: 37 KB Image Size: 640 x 480	<pre>I = imread('street1.jpg'); imshow(I)</pre>
street2.jpg 	A picture of a busy city intersection. File Size: 39 KB Image Size: 640 x 480	<pre>I = imread('street2.jpg'); imshow(I)</pre>
mri.mat 	An MRI data set that contains 27 image slices of a human head. The images are arranged into a 4-D array of size 128-by-128-by-1-by-27. File Size: 130 KB Image Size: 302 x 221	<pre>load mri.mat imshow(D(:,:,:,1),map)</pre> <p>For more information, see “Techniques for Visualizing Scalar Volume Data”.</p>
durer.mat 	An image of Albrecht Dürer's <i>Melancholia</i> . Can you find the magic square matrix? File Size: 273 KB Image Size: 683 x 741	<pre>load durer.mat imshow(X,map)</pre>
peppers.png 	A colorful picture of several varieties of peppers. File Size: 281 KB Image Size: 512 x 384	<pre>I = imread('peppers.png'); imshow(I)</pre>

Filename	Description	How to Load
<p>corn.tif</p> 	<p>A TIF file containing three images of corn (indexed, RGB, and grayscale).</p> <p>File Size: 226 KB</p> <p>Image Size: 312 x 415</p>	<p>View the indexed version of the image.</p> <pre>[corn_indexed,map] = imread('corn.tif',1); imshow(corn_indexed,map)</pre> <p>View the RGB version of the image.</p> <pre>corn_rgb = imread('corn.tif',2); imshow(corn_rgb)</pre> <p>View the grayscale version of the image.</p> <pre>corn_gray = imread('corn.tif',3); imshow(corn_gray)</pre>
<p>flujet.mat</p> 	<p>An image of a simulation of an astrophysical jet experiencing turbulence.</p> <p>File Size: 21 KB</p> <p>Image Size: 474 x 493</p>	<pre>load flujet.mat imshow(X,map)</pre>
<p>spine.mat</p> 	<p>An X-ray image of a human spine.</p> <p>File Size: 33 KB</p> <p>Image Size: 664 x 460</p>	<pre>load spine.mat imshow(X,map)</pre>
<p>mandrill.mat</p> 	<p>A colorful picture of a mandrill.</p> <p>File Size: 184 KB</p> <p>Image Size: 674 x 573</p>	<pre>load mandrill.mat imshow(X,map)</pre>

Geographic Data

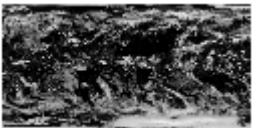
Filename	Description	How to Load
earth.mat 	A picture of earth. File Size: 32 KB Image Size: 424 x 350	load <code>earth.mat</code> <code>imshow(X,map)</code>
cape.mat 	NOAA altitude data for New England, including Cape Cod. File Size: 37 KB Image Size: 534 x 453	load <code>cape.mat</code> <code>imshow(X,map)</code>
landOcean.jpg 	An image of the earth. This image can be combined with <code>cloudCombined.jpg</code> to view a map of the earth with cloud cover. File Size: 261 KB Image Size: 2048 x 1024	View the earth image: <code>E = imread('landOcean.jpg');</code> <code>imshow(E)</code> View the cloud cover image: <code>C = imread('cloudCombined.jpg');</code> <code>imshow(C)</code>
cloudCombined.jpg 	An image of cloud coverage on the earth. This image can be combined with <code>landOcean.jpg</code> to view a map of the earth with cloud cover. File Size: 810 KB Image Size: 2048 x 1024	See “Changing Transparency of Images, Patches or Surfaces” for an example that overlays both images with transparency.
tsunamis.xlsx	Data on tsunami occurrences, including locations. File Size: 25 KB Data Size: 162 rows, 20 variables	<code>T = readtable('tsunamis.xlsx');</code> <code>geobubble(T.Latitude,T.Longitude,T.MaxH</code>
topo.mat	Earth topography data, courtesy of the NOAA. File Size: 115 KB Data Size: Altitude data is a 180-by-360 matrix	See “Displaying Topographic Data”.

Filename	Description	How to Load
usapolygon.mat	<p>Latitude and longitude data for the perimeter of the contiguous United States.</p> <p>File Size: 17 KB</p> <p>Data Size: Two vectors with 4,205 elements</p>	load <code>usapolygon.mat</code>
usastates.mat	<p>Latitude and longitude data for each state in the contiguous United States. The data contains a structure array with three fields: Lat, Lon, and Name.</p> <p>File Size: 45 KB</p> <p>Data Size: Structure array of size 49-by-1</p>	load <code>usastates.mat</code>

Video and Audio Data

Filename	Description	How to Load
shuttle.avi	<p>Video of a space shuttle launch without audio, courtesy of NASA.</p> <p>File Size: 1,648 KB</p> <p>Video Length: 4 s</p>	<p>To watch the video on your computer:</p> <pre>winopen('shuttle.avi')</pre>
xylophone.mp4 xylophone.mpg	<p>Video of a xylophone being played. The MPG version has audio.</p> <p>File Size: 465 KB (mp4) and 645 KB (mpg)</p> <p>Video Length: 4 s</p>	<p>To watch the videos on your computer:</p> <pre>winopen('xylophone.mp4')</pre> <p>or</p> <pre>winopen('xylophone.mpg')</pre>
handel.mat	<p>An excerpt of the Hallelujah chorus from Handel's <i>Messiah</i>.</p> <p>File Size: 137 KB</p> <p>Audio Length: 8.9 s</p>	load <code>handel.mat</code> sound(y, Fs)
chirp.mat	<p>Birds chirping.</p> <p>File Size: 25 KB</p> <p>Audio Length: 1.6 s</p>	load <code>chirp.mat</code> sound(y, Fs)

Filename	Description	How to Load
gong.mat	A gong ringing. File Size: 90 KB Audio Length: 5.1 s	load <code>gong.mat</code> sound(y,Fs)
laughter.mat	Hearty laughter. File Size: 121 KB Audio Length: 6.4 s	load <code>laughter.mat</code> sound(y,Fs)
mtlb.mat	A person saying "MATLAB". File Size: 32 KB Audio Length: 0.5 s	load <code>mtlb.mat</code> sound(mtlb,Fs)
splat.mat	A comical splat sound. File Size: 18 KB Audio Length: 1.2 s	load <code>splat.mat</code> sound(y,Fs)
train.mat	A train whistle. File Size: 30 KB Audio Length: 1.6 s	load <code>train.mat</code> sound(y,Fs)

See Also

load | save | imshow | sound | table

More About

- “Data Sets for Deep Learning” (Deep Learning Toolbox)
- “Sample Data Sets” (Statistics and Machine Learning Toolbox)
- “Data Sets and Examples” (Econometrics Toolbox)

Save and Load Parts of Variables in MAT-Files

In this section...

“Save and Load Using the `matfile` Function” on page 1-18

“Load Parts of Variables Dynamically” on page 1-19

“Avoid Inadvertently Loading Entire Variables” on page 1-20

“Partial Loading and Saving Requires Version 7.3 MAT-Files” on page 1-20

You can save and load parts of variables directly in MAT-files without loading them into memory using the `matfile` function. The primary advantage of using the `matfile` function over the `load` or `save` functions is that you can process parts of very large data sets that are otherwise too large to fit in memory. When working with these large variables, read and write as much data into memory as possible at a time. Otherwise, repeated file access can negatively impact the performance of your code.

Save and Load Using the `matfile` Function

This example shows how to load, modify, and save part of a variable in an existing MAT-file using the `matfile` function.

Create a Version 7.3 MAT-file with two variables, A and B.

```
A = rand(5);  
B = magic(10);  
save example.mat A B -v7.3;  
clear A B
```

Construct a `MatFile` object from the MAT-file, `example.mat`. The `matfile` function creates a `MatFile` object that corresponds to the MAT-file and contains the properties of the `MatFile` object. By default, `matfile` only permits loading from existing MAT-files.

```
exampleObject = matfile('example.mat');
```

To enable saving, call `matfile` with the `Writable` parameter.

```
exampleObject = matfile('example.mat','Writable',true);
```

Alternatively, construct the object and set `Properties.Writable` in separate steps.

```
exampleObject = matfile('example.mat');  
exampleObject.Properties.Writable = true;
```

Load the first row of B from `example.mat` into variable `firstRowB` and modify the data. When you index into objects associated with Version 7.3 MAT-files, MATLAB® loads only the part of the variable that you specify.

```
firstRowB = exampleObject.B(1,:);  
firstRowB = 2 * firstRowB;
```

Update the values in the first row of variable B in `example.mat` using the values stored in `firstRowB`.

```
exampleObject.B(1,:) = firstRowB;
```

For very large files, the best practice is to read and write as much data into memory as possible at a time. Otherwise, repeated file access negatively impacts the performance of your code. For example, suppose that your file contains many rows and columns, and that loading a single row requires most of the available memory. Rather than updating one element at a time, update each row.

```
[nrowsB,ncolsB] = size(exampleObject,'B');
for row = 1:nrowsB
    exampleObject.B(row,:) = row * exampleObject.B(row,:);
end
```

If memory is not a concern, you can update the entire contents of a variable at a time.

```
exampleObject.B = 10 * exampleObject.B;
```

Alternatively, update a variable by calling the `save` function with the `-append` option. The `-append` option requests that the `save` function replace only the specified variable, `B`, and leave other variables in the file intact. This method always requires that you load and save the entire variable.

```
load('example.mat','B');
B(1,:) = 2 * B(1,:);
save('example.mat','-append','B');
```

Add a variable to the file using the `matlab.io.MatFile` object.

```
exampleObject.C = magic(8);
```

You also can add the variable by calling the `save` function with the `-append` option.

```
C = magic(8);
save('example.mat','-append','C');
clear C
```

Load Parts of Variables Dynamically

This example shows how to access parts of variables from a MAT-file dynamically. This is useful when working with MAT-files whose variables names are not always known.

Consider the example MAT-file, `topography.mat`, that contains one or more arrays with unknown names. Construct a `MatFile` object that corresponds to the file, `topography.mat`. Call `who` to get the variable names in the file.

```
exampleObject = matfile('topography.mat');
varlist = who(exampleObject)

varlist = 4x1 cell
    {'topo'      }
    {'topolegend'}
    {'topomap1'  }
    {'topomap2'  }
```

`varlist` is a cell array containing the names of the four variables in `topography.mat`.

The third and fourth variables, `topomap1` and `topomap2`, are both arrays containing colormap data. Load the colormap data from the third column of each variable into a field of the structure array, `S`. For each field, specify a field name that is the original variable name prefixed by `colormap_`. Then, access the data in each variable as properties of `exampleObject`. Because `varName` is a variable, enclose it in parentheses.

```
for index = 3:4
    varName = varlist{index};
    S(1).(['colormap_',varName]) = exampleObject.(varName)(:,3);
end
```

View the contents of the structure array, `S`.

```
S
S = struct with fields:
    colormap_topomap1: [64x1 double]
    colormap_topomap2: [128x1 double]
```

`S` has two fields, `colormap_topomap1` and `colormap_topomap2`, each containing a column vector.

Avoid Inadvertently Loading Entire Variables

When you do not know the size of a large variable in a MAT-file and want to load only parts of that variable at a time, avoid using the `end` keyword. Using the `end` keyword temporarily loads the entire contents of the variable in question into memory. For very large variables, loading takes a long time or generates Out of Memory errors. Instead, call the `size` method for `MatFile` objects.

For example, this code temporarily loads the entire contents of `B` in memory:

```
lastColB = exampleObject.B(:,end);
```

Use this code instead to improve performance:

```
[nrows,ncols] = size(exampleObject,'B');
lastColB = exampleObject.B(:,ncols);
```

Similarly, any time you refer to a variable with syntax of the form `matObj.varName`, such as `exampleObject.B`, MATLAB temporarily loads the entire variable into memory. Therefore, make sure to call the `size` method for `MatFile` objects with syntax such as:

```
[nrows,ncols] = size(exampleObject,'B');
```

rather than passing the entire contents of `exampleObject.B` to the `size` function,

```
[nrows,ncols] = size(exampleObject.B);
```

The difference in syntax is subtle, but significant.

Partial Loading and Saving Requires Version 7.3 MAT-Files

Any load or save operation that uses a `MatFile` object associated with a Version 7 or earlier MAT-file temporarily loads the entire variable into memory.

Use the `matfile` function to create files in Version 7.3 format. For example, this code

```
newfile = matfile('newfile.mat');
```

creates a MAT-file that supports partial loading and saving.

However, by default, the `save` function creates Version 7 MAT-files. Convert existing MAT-files to Version 7.3 by calling the `save` function with the `-v7.3` option, such as:

```
load('durer.mat');  
save('mycopy_durer.mat', '-v7.3');
```

To change your preferences to save new files in Version 7.3 format, access the **Environment** section on the **Home** tab, and click  **Preferences**. Select **MATLAB > General > MAT-Files**. This preference is not available in MATLAB Online™.

See Also

[matfile](#) | [save](#) | [load](#)

More About

- “Save and Load Workspace Variables”
- “Growing Arrays Using `matfile` Function” on page 1-25
- “MAT-File Versions” on page 1-22

MAT-File Versions

In this section...
“Overview of MAT-File Versions” on page 1-22
“Save to Nondefault MAT-File Version” on page 1-23
“Data Compression” on page 1-23
“Accelerate Save and Load Operations for Version 7.3 MAT-Files” on page 1-24

Overview of MAT-File Versions

MAT-files are binary MATLAB files that store workspace variables. Starting with MAT-file Version 4, there are several subsequent versions of MAT-files that support an increasing set of features. MATLAB releases R2006b and later all support all MAT-file versions.

By default, all save operations create Version 7 MAT-files. The only exception to this is when you create new MAT-files using the `matfile` function. In this case, the default MAT-file version is 7.3.

To identify or change the default MAT-file version, access the MAT-Files Preferences.

- On the **Home** tab, in the **Environment** section, click  **Preferences**.
- Select **MATLAB > General > MAT-Files**.

The preferences apply to both the save function and the **Save** menu options.

The maximum size of a MAT-file is imposed only by your native file system.

This table lists and compares all MAT-file versions.

MAT-File Version	Supported MATLAB Releases	Supported Features	Compression	Maximum Size of Each Variable	Value of version argument in save function	Preference Option
Version 7.3	R2006b (Version 7.3) or later	Saving and loading parts of variables, and all Version 7 features	Yes (default)	≥ 2 GB on 64-bit computers	' -v7.3 '	MATLAB Version 7.3 or later (save -v7.3)
Version 7	R14 (Version 7.0) or later	Unicode® character encoding, which enables file sharing between systems that use different default character encoding schemes, and all Version 6 features.	Yes (default)	2 ³¹ bytes per variable	' -v7 '	MATLAB Version 7 or later (save -v7)

MAT-File Version	Supported MATLAB Releases	Supported Features	Compression	Maximum Size of Each Variable	Value of version argument in save function	Preference Option
Version 6	R8 (Version 5) or later	N-dimensional arrays, cell arrays, structure arrays, variable names longer than 19 characters, and all Version 4 features.	No	2^{31} bytes per variable	' -v6 '	MATLAB Version 5 or later (save -v6)
Version 4	All	Two-dimensional double, character, and sparse arrays	No	100,000,000 elements per array, and 2^{31} bytes per variable	' -v4 '	n/a

Note Version 7.3 MAT-files use an HDF5 based format that requires some overhead storage to describe the contents of the file. For cell arrays, structure arrays, or other containers that can store heterogeneous data types, Version 7.3 MAT-files are sometimes larger than Version 7 MAT-files.

Save to Nondefault MAT-File Version

Save to a MAT-file version other than the default version when you want to:

- Allow access to the file using earlier versions of MATLAB.
- Take advantage of Version 7.3 MAT-file features.
- Reduce the time required to load and save some files by storing uncompressed data.
- Reduce the size of some files by storing compressed data.

To save to a MAT-file version other than the default version, specify a `version` as the last input to the `save` function. For example, to create a Version 6 MAT-file named `myfile.mat`, type:

```
save('myfile.mat', '-v6')
```

Data Compression

Beginning with Version 7, MATLAB compresses data when writing to MAT-files to save storage space. Data compression and decompression slow down all save operations and some load operations. In most cases, the reduction in file size is worth the additional time spent.

In some cases, loading compressed data actually can be *faster* than loading uncompressed data. For example, consider a block of data in a numeric array saved to both a 10 MB compressed file and a 100 MB uncompressed file. Loading the first 10 MB takes the same amount of time for each file. Loading the remaining 90 MB from the uncompressed file takes nine times as long as loading the first 10 MB. Completing the load of the compressed file requires only the relatively short time to decompress the data.

The benefits of data compression are negligible in the following cases:

- The amount of data in each item is small relative to the complexity of its container. For example, simple numeric arrays take less time to compress and uncompress than cell or structure arrays of the same size. Compressing arrays that result in an uncompressed file size of less than 3 MB offers limited benefit, unless you are transferring data over a network.
- The data is random, with no repeated patterns or consistent values.

Accelerate Save and Load Operations for Version 7.3 MAT-Files

Version 7.3 MAT-files use an HDF5-based format that stores data in compressed chunks. The time required to load part of a variable from a Version 7.3 MAT-file depends on how that data is stored across one or more chunks. Each chunk that contains any portion of the data you want to load must be fully uncompressed to access the data. Rechunking your data can improve the performance of the load operation. To rechunk data, use the HDF5 command-line tools, which are part of the HDF5 distribution.

See Also

`save` | `matfile`

More About

- “Save and Load Workspace Variables”

Growing Arrays Using `matfile` Function

When writing a large number of large values to a MAT-file, the size of the file increases in a nonincremental way. This method of increase is expected. To minimize the number of times the file must grow and ensure optimal performance though, assign initial values to the array prior to populating it with data.

For example, suppose that you have a writable `MatFile` object.

```
fileName = 'matFileOfDoubles.mat';
matObj = matfile(fileName);
matObj.Properties.Writable = true;
```

Define parameters of the values to write. In this case, write one million values, fifty thousand at a time. The values should have a mean of 123.4, and a standard deviation of 56.7.

```
size = 1000000;
chunk = 50000;
mean = 123.4;
std = 56.7;
```

Assign an initial value of zero to the last element in the array prior to populating it with data.

```
matObj.data(1,size) = 0;
```

View the size of the file.

- On Windows systems, use `dir`.

```
system('dir matFileOfDoubles.mat');
```

- On UNIX® systems, use `ls -ls`:

```
system('ls -ls matFileOfDoubles.mat');
```

In this case, `matFileOfDoubles.mat` is less than 5000 bytes. Assigning an initial value to the last element of the array does not create a large file. It does, however, prepare your system for the potentially large size increase of `matFileOfDoubles.mat`.

Write data to the array, one chunk at a time.

```
nout = 0;
while(nout < size)
    fprintf('Writing %d of %d\n',nout,size);
    chunkSize = min(chunk,size-nout);
    data = mean + std * randn(1,chunkSize);
    matObj.data(1,(nout+1):(nout+chunkSize)) = data;
    nout = nout + chunkSize;
end
```

View the size of the file.

```
system('dir matFileOfDoubles.mat');
```

The file size is now larger because the array is populated with data.

See Also

`matfile`

More About

- “Save and Load Parts of Variables in MAT-Files” on page 1-18

Unexpected Results When Loading Variables Within a Function

If you have a function that loads data from a MAT-file and find that MATLAB does not return the expected results, check whether any variables in the MAT-file share the same name as a MATLAB function. Common variable names that conflict with function names include `i`, `j`, `mode`, `char`, `size`, and `path`.

These unexpected results occur because when you execute a function, MATLAB preprocesses all the code in the function before running it. However, calls to `load` are not preprocessed, meaning MATLAB has no knowledge of the variables in your MAT-file. Variables that share the same name as MATLAB functions are, therefore, preprocessed as MATLAB functions, causing the unexpected results. This is different from scripts, which MATLAB preprocesses and executes line by line, similar to the Command Window.

For example, consider a MAT-file with variables `height`, `width`, and `length`. If you load these variables in a function such as `findVolume`, MATLAB interprets the reference to `length` as a call to the MATLAB `length` function, and returns an error.

```
function vol = findVolume(myfile)
    load(myfile);
    vol = height * width * length;
end
```

```
Error using length
Not enough input arguments.
```

To avoid confusion, when defining your function, choose one (or more) of these approaches:

- Load the variables into a structure array. For example:

```
function vol = findVolume(myfile)
    dims = load(myfile);
    vol = dims.height * dims.width * dims.length;
end
```

- Explicitly include the names of variables in the call to the `load` function. For example:

```
function vol = findVolume(myfile)
    load(myfile, 'height', 'width', 'length')
    vol = height * width * length;
end
```

- Initialize the variables within the function before calling `load`. To initialize a variable, assign it to an empty matrix or an empty character vector. For example:

```
function vol = findVolume(myfile)
    height = [];
    width = [];
    length = [];
    load(myfile);
    vol = height * width * length;
```

To determine whether a particular variable name is associated with a MATLAB function, use the `exist` function. A return value of 5 determines that the name is a built-in MATLAB function.

See Also

`load`

More About

- “Save and Load Workspace Variables”

Create Temporary Files

Use the `tempdir` function to return the name of the folder designated to hold temporary files on your system. For example, issuing `tempdir` on The Open Group UNIX systems returns the `/tmp` folder.

Use the `tempname` function to return a file name in the temporary folder. The returned file name is a suitable destination for temporary data. For example, if you need to store some data in a temporary file, then you might issue the following command first:

```
fileID = fopen(tempname, 'w');
```

In most cases, `tempname` generates a universally unique identifier (UUID). However, if you run MATLAB without JVM™, then `tempname` generates a random name using the CPU counter and time, and this name is not guaranteed to be unique.

Some systems delete temporary files every time you reboot the system. On other systems, designating a file as temporary means only that the file is not backed up.

Text Files

- “Import Text Files” on page 2-2
- “Read Text File Data Using Import Tool” on page 2-6
- “Import Dates and Times from Text Files” on page 2-10
- “Import Numeric Data from Text Files into Matrix” on page 2-14
- “Import Mixed Data from Text File into Table” on page 2-16
- “Import Block of Mixed Data from Text File into Table or Cell Array” on page 2-19
- “Write Data to Text Files” on page 2-22
- “Write to a Diary File” on page 2-26
- “Read Collection or Sequence of Text Files” on page 2-27
- “Import Block of Numeric Data from Text File” on page 2-30

Import Text Files

MATLAB can read and write numeric and nonnumeric data from delimited and formatted text files, including `.csv` and `.txt` files. Text files often contain a mix of numeric and text data as well as variable and row names. You can represent this data in MATLAB as tables, timetables, matrices, cell arrays, or string arrays.

Import data from text files either programmatically or interactively. Import programmatically to use tailored import functions and further control how your data is imported using import options. Import interactively to use the **Import Tool** and its user interface.

Import Data as Tables

If your text file has tabular data, you can import the data as a table. A table consists of column-oriented variables containing rows of data of the same type. Each variable in a table can hold a different data type and size, however, each variable must have the same number of rows. For more information about tables, see “Create Tables and Assign Data to Them”.

Import tabular data from a text file into a table using the `readtable` function with the file name. For example, create a table from the sample file `airlinesmall.csv`.

```
T = readtable('airlinesmall.csv');
```

Display the first five rows and columns of the table.

```
T(1:5,1:5)
```

```
ans =
```

```
5×5 table
```

Year	Month	DayofMonth	DayOfWeek	DepTime
1987	10	21	3	{'642' }
1987	10	26	1	{'1021' }
1987	10	23	5	{'2055' }
1987	10	23	5	{'1332' }
1987	10	22	4	{'629' }

Import Data as Timetables

If your text file has tabular data where each row is associated with a time, you can import the data as a timetable. Like tables, timetables allow you to store tabular data variables that can have different data types and sizes as long as they have the same number of rows. In addition, a timetable provides time-specific functions to align, combine, and perform calculations with time-stamped data in one or more timetables. For more information about timetables, see “Create Timetables”.

Import tabular data from a text file into a timetable using the `readtimetable` function. For example, create a timetable from the sample file `outages.csv`.

```
TT = readtimetable('outages.csv');
```

Display the first five rows and columns of the timetable.

```
TT(1:5,1:5)
```

```
ans =
```

```
5×5 timetable
```

OutageTime	Region	Loss	Customers	RestorationTime	Cause
2002-02-01 12:18	{'SouthWest'}	458.98	1.8202e+06	2002-02-07 16:50	{'winter st
2003-01-23 00:49	{'SouthEast'}	530.14	2.1204e+05	NaT	{'winter st
2003-02-07 21:15	{'SouthEast'}	289.4	1.4294e+05	2003-02-17 08:14	{'winter st
2004-04-06 05:44	{'West' }	434.81	3.4037e+05	2004-04-06 06:10	{'equipment
2002-03-16 06:18	{'MidWest' }	186.44	2.1275e+05	2002-03-18 23:23	{'severe st

Import Data as Matrices

If your text file contains uniform data (all of the same type), you can import the data as a matrix. Importing your data into a matrix allows you to work with a minimally formatted array.

Import tabular data from a text file into a matrix using `readmatrix`. For example, import the data from the sample file `basic_matrix.txt` into a matrix.

```
M = readmatrix('basic_matrix.txt')
```

```
M = 5×4
```

```

6     8     3     1
5     4     7     3
1     6     7    10
4     2     8     2
2     7     5     9
```

Import Data as Cell Arrays

A cell array is a data type with indexed data containers called cells, where each cell can contain any type of data. Cell arrays commonly contain either lists of text, combinations of text and numbers, or numeric arrays of different sizes.

You can import non-uniform data (each column having a different type) from a text file into a cell array using `readcell`. For example, display the contents of `basic_cell.txt`, and then import the mixed data into a cell array.

```
type basic_cell.txt
```

```
1,2,3
hello,world,NaN
10-Oct-2018 10:27:56,1,
```

```
C = readcell('basic_cell.txt')
```

```
C=3×3 cell array
```

```

    {[           1]}    {[           2]}    {[           3]}
    {'hello'       }    {'world'     }    {[           NaN]}
    {[10-Oct-2018 10:27:56]}  {[           1]}    {1x1 missing}
```

Alternatively, you can import formatted data from a text file into a cell array using the `textscan` function and a low-level I/O workflow. Low-level I/O workflows allow for the most control over

importing data. This degree of control is not necessary for most workflows. For more information on importing text data with low-level I/O, see “Import Text Data Files with Low-Level I/O” on page 4-2.

Import Data as String Arrays

If your text file contains lines of plain text, you can represent the plain text in MATLAB as a string array. String arrays store pieces of text and provide a set of functions for working with text as data. For example, you can index into, reshape, and concatenate strings arrays just as you can with arrays of any other type.

Import lines of plain text in a text file into string arrays using `readlines`. For example, create a string array from the sample text file, `badpoem.txt`. Since the text file has four lines of plain text, the function creates a 4-by-1 string array.

```
lines = readlines("badpoem.txt")  
  
lines = 4x1 string  
    "Oranges and lemons,"  
    "Pineapples and tea."  
    "Orangutans and monkeys,"  
    "Dragonflies or fleas."
```

Import Data with Import Options for Additional Control

Importing tabular data sometimes requires additional control over the import process. To customize the import process, you can create an import options object. The object has properties that you can adjust based on your import needs. For example, you can change the data types of variables or import only a subset of variables. For more information about import options, see `detectImportOptions`.

Import Data Interactively

If you would prefer to use the user interface, you can import data interactively into a table or other data type using the **Import Tool**.

To open the **Import Tool**, within the **Home** tab, in the **Variable** section, click **Import Data** . Alternatively, right-click the name of the file in the Current Folder browser and select **Import Data**. Then, select the file you want to import. Using the **Import Tool** window, set the importing options and then click **Import Selection** to import the data into MATLAB. For more information, see “Read Text File Data Using Import Tool” on page 2-6.

The screenshot shows the 'Import Tool' interface with the 'VIEW' tab selected. The 'Delimited' option is chosen, and the column delimiter is set to 'Space'. The range is 'A2:D5' and the variable names row is '1'. The 'Output Type' is 'Column vectors'. Below the settings, a table titled 'grades.txt' is displayed with columns A, B, C, and D, and rows 1 through 5. The data in the table is as follows:

	A	B	C	D
	John	Ann	Mark	Rob
	Number	Number	Number	Number
1	John	Ann	Mark	Rob
2	88.4	91.5	89.2	77.3
3	83.2	88.0	67.8	91.0
4	77.8	76.3		92.5
5	92.1	96.4	81.2	84.6

See Also

Import Tool | readtable | table | readtimetable | readmatrix | readcell | readlines | textscan | detectImportOptions

More About

- “Create Tables and Assign Data to Them”
- “Access Data in Tables”
- “Import Mixed Data from Text File into Table” on page 2-16
- “Create Timetables”
- “Read Text File Data Using Import Tool” on page 2-6

Read Text File Data Using Import Tool

In this section...

“Select Data Interactively” on page 2-6

“Import Data from Multiple Text Files” on page 2-8

Import data from a text file by selecting data interactively. You also can repeat this import operation on multiple text files by using the generate code feature of the import tool.

Select Data Interactively

This example shows how to import data from a text file with column headers and numeric data using the Import Tool. The file in the example, `grades.txt`, contains this data:

John	Ann	Mark	Rob
88.4	91.5	89.2	77.3
83.2	88.0	67.8	91.0
77.8	76.3		92.5
92.1	96.4	81.2	84.6

To create the file, copy and paste the data using any text editor.

On the **Home** tab, in the **Variable** section, click **Import Data** . Alternatively, right-click the name of the file in the Current Folder browser and select **Import Data**. The Import Tool opens.

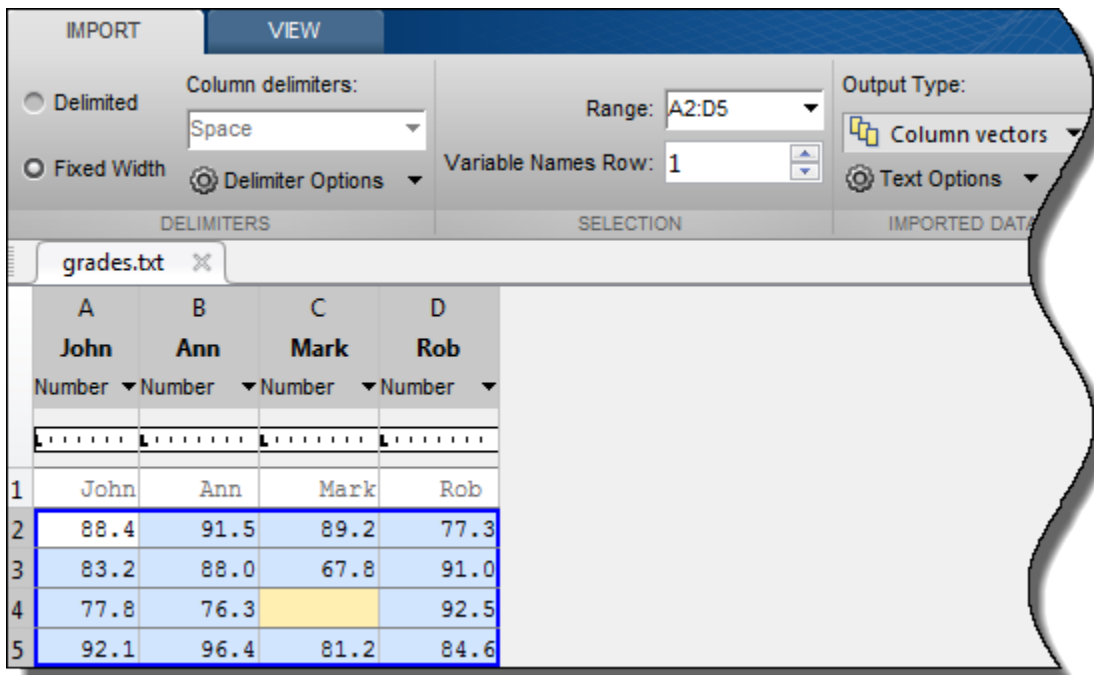

The screenshot shows the Import Tool interface with the 'Imported Data' section expanded. The 'Imported Data' section displays a table with the following data:

	A	B	C	D
	John	Ann	Mark	Rob
	Number	Number	Number	Number
1	John	Ann	Mark	Rob
2	88.4	91.5	89.2	77.3
3	83.2	88.0	67.8	91.0
4	77.8	76.3		92.5
5	92.1	96.4	81.2	84.6

The Import Tool recognizes that `grades.txt` is a fixed width file. In the **Imported Data** section, select how you want the data to be imported. The following table indicates how data is imported depending on the option you select.

Option Selected	How Data is Imported
Table	Import selected data as a table.
Column vectors	Import each column of the selected data as an individual m-by-1 vector.
Numeric Matrix	Import selected data as an m-by-n numeric array.
String Array	Import selected data as a string array that contains text.
Cell Array	Import selected data as a cell array that can contain multiple data types, such as numeric data and text.

Under **Delimiter Options**, you can specify whether the Import Tool should use a period or a comma as the decimal separator for numeric values.

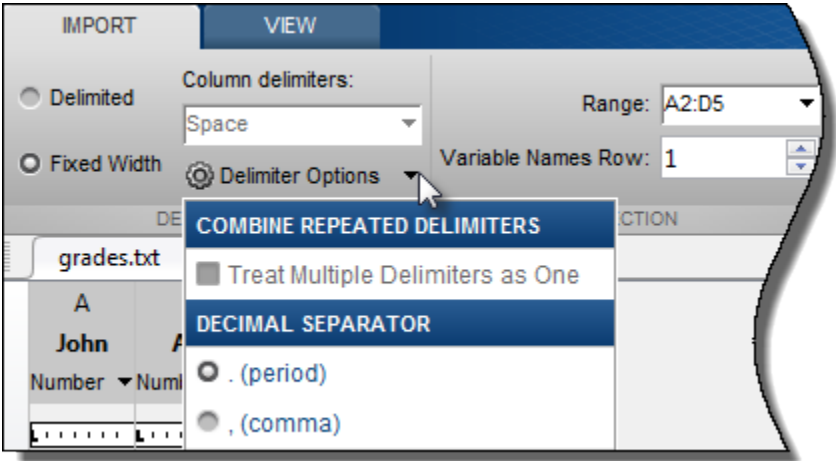

Double-click a variable name to rename it.

	A	B	C	D
	John	Ann	Mark	Rob
	N...	NUMBER	NUMBER	NUMBER
1	John	Ann	Mark	Rob
2	88.4	91.5	89.2	77.3
3	83.2	88.0	67.8	91.0
4	77.8	76.3		92.5
5	92.1	96.4	81.2	84.6

You also can use the **Variable Names Row** box in the **Selection** section to select the row in the text file that you want the Import Tool to use for variable names.

The Import Tool highlights unimportable cells. Unimportable cells are cells that contain data that cannot be imported in the format specified for that column. In this example, the cell at row 3, column C, is considered unimportable because a blank cell is not numeric. Highlight colors correspond to

proposed rules to make the data fit into a numeric array. You can add, remove, reorder, or edit rules, such as changing the replacement value from NaN to another value.

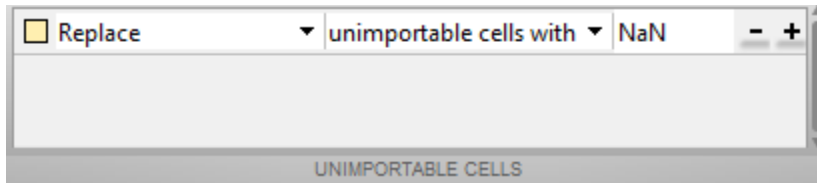

All rules apply to the imported data only and do not change the data in the file. Any time you are importing into a matrix or into numeric column vectors and the range includes non-numeric data, then you must specify the rules.

To see how your data is imported, place the cursor over individual cells.

	A	B	C	D
	John	Ann	Mark	Rob
	N...	NUMBER	NUMBER	NUMBER
1	John	Ann	Mark	Rob
2	88.4	91.5	89.2	77.3
3	83.2	88.0	Replaced by:NaN	
4	77.8	76.3	NaN	92.5
5	92.1	96.4	81.2	84.6

When you click the **Import Selection** button , the Import Tool creates variables in your workspace.

For more information on interacting with the Import Tool, watch this video.

Import Data from Multiple Text Files

To perform the same import operation on multiple files, use the code generation feature of the Import Tool. If you import a file one time and generate code from the Import Tool, you can use this code to make it easier to repeat the operation. The Import Tool generates a program script that you can edit and run to import the files, or a function that you can call for each file.

Suppose you have a set of text files in the current folder. The files are named `myfile01.txt` through `myfile25.txt`, and you want to import the data from each file, starting from the second row. Generate code to import the entire set of files as follows:

- 1 Open one of the files in the Import Tool.
- 2 Click **Import Selection** , and then select **Generate Function**. The Import Tool generates code similar to the following excerpt, and opens the code in the Editor.

```
function data = importfile(filename,startRow,endRow)
%IMPORTFILE Import numeric data from a text file as a matrix.
...
```

- 3 Save the function.
- 4 In a separate program file or at the command line, create a `for` loop to import data from each text file into a cell array named `myData`:

```
numFiles = 25;
startRow = 2;
endRow = inf;
myData = cell(1,numFiles);

for fileNum = 1:numFiles
    fileName = sprintf('myfile%02d.txt',fileNum);
    myData{fileNum} = importfile(fileName,startRow,endRow);
end
```

Each cell in `myData` contains an array of data from the corresponding text file. For example, `myData{1}` contains the data from the first file, `myfile01.txt`.

See Also

`readtable` | `textscan` | `readmatrix` | `readcell` | `readvars` | `readtimetable`

More About

- “Import Text Files” on page 2-2

Import Dates and Times from Text Files

Import formatted dates and times (such as '01/01/01' or '12:30:45') from column oriented tabular data in three ways.

- Import Tool — Interactively select and import dates and times.
- `readtable` function — Automatically detect variables with dates and times and import them into a table.
- Import Options — Use `readtable` with `detectImportOptions` function for more control over importing date and time variables. For example, you can specify properties such as `FillValue` and `DatetimeFormat`.

This example shows you how to import dates and times from text files using each of these methods.

Import Tool

Open the file `outages.csv` using the Import Tool. Specify the formats of dates and times using the drop-down menu for each column. You can select from a predefined date format, or enter a custom format. To import the `OutageTime` column, specify the custom format `yyyy-MM-dd HH:mm`. Then, click the **Import Selection** button to import the data into the workspace.

The screenshot shows the 'VIEW' tab of a data import tool. The 'Imported Data' section shows a table with columns: Region, OutageTime, Loss, Customers, and RestorationTime. The 'OutageTime' column is selected, and a dropdown menu is open, showing options: Text (string), Text, Number (double), Number, Categories (categorical), Categorical, Dates and Times (datetime), and more date formats... A tooltip points to the 'Dates and Times (datetime)' option.

	A	B	C	D	E
				outages	
	Region	OutageTime	Loss	Customers	RestorationTime
	Categorical	Datetime	Number	Number	Text
1	Region	Text (string)			RestorationTime
2	SouthWest	Text			2002-02-07 16:50
3	SouthEast	Text like 1.234 will convert to string "1.234"			
4	SouthEast	Number (double)			2003-02-17 08:14
5	West	Number			2004-04-06 06:10
6	MidWest	Text like "1.234" will convert to number 1.234			2002-03-18 23:23
7	West	Categories (categorical)			2003-06-18 10:54
8	West	Categorical			2004-06-20 19:16
9	West	Text like 'orange' will convert to categorical orange			2002-06-07 00:51
10	NorthEast	Dates and Times (datetime)			2003-07-17 01:12
11	MidWest	yyyy-MM-dd HH:mm			2004-09-27 16:37
12	SouthEast	Custom Date Format like MM-dd-yyyy hh:mm:ss.SSS			2004-09-05 20:46
13	West	more date formats ...			2004-05-22 04:23
14	SouthEast				2002-09-01 19:12
15	SouthEast	2003-09-27 07:32		355170.6825	2003-10-04 07:02
16	West	2003-11-12 06:12	254.0860816	924291.6474	2003-11-17 02:04
17		2004-09-18 05:54	0		
		2004-10-42			2003-03-31

readtable Function

Use the `readtable` function and display 10 rows of the `OutageTime` variable. `readtable` automatically detects the date time variables and formats.

```
filename = 'outages.csv';
T = readtable(filename);
T.OutageTime(1:10)
```

```
ans = 10x1 datetime
    2002-02-01 12:18
    2003-01-23 00:49
    2003-02-07 21:15
    2004-04-06 05:44
    2002-03-16 06:18
    2003-06-18 02:49
```

```

2004-06-20 14:39
2002-06-06 19:28
2003-07-16 16:23
2004-09-27 11:09

```

Import Options

Use an import options object for more control over importing date and time variables. For example, change the date-time display format or specify a fill value for missing dates.

Create an import options object for the `outages.csv` file and display the variable import options for the variable `RestorationTime`. The `detectImportOptions` function automatically detects the data types of the variables.

```

opts = detectImportOptions(filename);
getvaropts(opts, 'RestorationTime')

ans =
  DatetimeVariableImportOptions with properties:

  Variable Properties:
      Name: 'RestorationTime'
      Type: 'datetime'
      FillValue: NaT
      TreatAsMissing: {}
      QuoteRule: 'remove'
      Prefixes: {}
      Suffixes: {}
      EmptyFieldRule: 'missing'

  Datetime Options:
      DatetimeFormat: 'default'
      DatetimeLocale: 'en_US'
      InputFormat: ''
      TimeZone: ''

```

Import the data and display the first 10 rows of the variable `RestorationTime`. The second row contains a `NaT`, indicating a missing date and time value.

```

T = readtable(filename,opts);
T.RestorationTime(1:10)

ans = 10x1 datetime
    2002-02-07 16:50
      NaT
    2003-02-17 08:14
    2004-04-06 06:10
    2002-03-18 23:23
    2003-06-18 10:54
    2004-06-20 19:16
    2002-06-07 00:51
    2003-07-17 01:12
    2004-09-27 16:37

```

To use a different date-time display format, update the `DatetimeFormat` property, and then replace missing values with the current date and time by using the `FillValue` property. Display the updated variable options.

```
opts = setvaropts(opts, 'RestorationTime', ...
                 'DatetimeFormat', 'MMMM d, yyyy HH:mm:ss Z', ...
                 'FillValue', 'now');
getvaropts(opts, 'RestorationTime')
```

```
ans =
  DatetimeVariableImportOptions with properties:
```

```
Variable Properties:
    Name: 'RestorationTime'
    Type: 'datetime'
    FillValue: August 31, 2022 08:37:04 *
    TreatAsMissing: {}
    QuoteRule: 'remove'
    Prefixes: {}
    Suffixes: {}
    EmptyFieldRule: 'missing'

Datetime Options:
    DatetimeFormat: 'MMMM d, yyyy HH:mm:ss Z'
    DatetimeLocale: 'en_US'
    InputFormat: ''
    TimeZone: ''
```

Read the data with the updated import options and display the first 10 rows of the variable.

```
T = readtable(filename,opts);
T.RestorationTime(1:10)
```

```
ans = 10x1 datetime
    2002-02-07 16:50
    2022-08-31 08:37
    2003-02-17 08:14
    2004-04-06 06:10
    2002-03-18 23:23
    2003-06-18 10:54
    2004-06-20 19:16
    2002-06-07 00:51
    2003-07-17 01:12
    2004-09-27 16:37
```

For more information on the `datetime` variable options, see the `setvaropts` reference page.

See Also

Import Tool | `readtable` | `detectImportOptions` | `setvaropts` | `readmatrix` | `readcell` | `readvars` | `readtimetable`

More About

- “Import Mixed Data from Text File into Table” on page 2-16

Import Numeric Data from Text Files into Matrix

Import numeric data as MATLAB arrays from files stored as comma-separated or delimited text files.

Import Comma-Separated Data

This example shows how to import comma-separated numeric data from a text file. Create a sample file, read all the data in the file, and then read only a subset starting from a specified location.

Create a sample file named `ph.dat` that contains comma-separated data and display the contents of the file.

```
rng('default')
A = 0.9*randi(99,[3 4]);
writematrix(A,'ph.dat','Delimiter','(',')
type('ph.dat')
```

```
72.9,81.9,25.2,86.4
81,56.7,49.5,14.4
11.7,9,85.5,87.3
```

Read the file using the `readmatrix` function. The function returns a 3-by-4 double array containing the data from the file.

```
M = readmatrix('ph.dat')
```

```
M = 3×4
```

```
72.9000    81.9000    25.2000    86.4000
81.0000    56.7000    49.5000    14.4000
11.7000     9.0000    85.5000    87.3000
```

Import only the rectangular portion of data starting from the first row and third column in the file. Create an import options object and specify the columns and rows to import using the `SelectedVariableNames` and `DataLines` properties. Then, import the selected portion of the data from the file.

```
opts = detectImportOptions('ph.dat');
opts.SelectedVariableNames = {'Var3','Var4'};
opts.DataLines = [1 3];
readmatrix('ph.dat',opts)
```

```
ans = 3×2
```

```
25.2000    86.4000
49.5000    14.4000
85.5000    87.3000
```

Import Delimited Numeric Data

This example shows how to import numeric data delimited by any single character using the `writematrix` function. Create a sample file, read the entire file, and then read a subset of the file starting at the specified location.

Create a tab-delimited file named `num.txt` that contains a 4-by-4 numeric array and display the contents of the file.

```
rng('default')
A = randi(99,[4,4]);
writematrix(A,'num.txt','Delimiter','\t')
type('num.txt')
```

```
81    63    95    95
90    10    96    49
13    28    16    80
91    55    97    15
```

Read the entire file. The `readmatrix` function determines the delimiter automatically and returns a 4-by-4 double array.

```
M = readmatrix('num.txt')
```

```
M = 4×4
```

```
    81    63    95    95
    90    10    96    49
    13    28    16    80
    91    55    97    15
```

Read only the rectangular block of data beginning from the second row, third column, in the file. Create an import options object and specify the columns and rows to import using the `SelectedVariableNames` and `DataLines` properties. Then, import the selected portion of the data from the file.

```
opts = detectImportOptions('num.txt');
opts.SelectedVariableNames = {'Var3','Var4'};
opts.DataLines = [2 4];
readmatrix('num.txt',opts)
```

```
ans = 3×2
```

```
    96    49
    16    80
    97    15
```

See Also

`readmatrix` | `readcell` | `readvars` | `readtimetable`

More About

- “Import Text Files” on page 2-2

Import Mixed Data from Text File into Table

This example shows how to use the `readtable` function to import mixed text and numeric data into a table, specify the data types for the variables, and then append a new variable to the table.

Sample File Overview

The sample file, `outages.csv`, contains data representing electric utility outages in the US. The first few lines of the file are:

```
Region,OutageTime,Loss,Customers,RestorationTime,Cause
SouthWest,2002-01-20 11:49,672,2902379,2002-01-24 21:58,winter storm
SouthEast,2002-01-30 01:18,796,336436,2002-02-04 11:20,winter storm
SouthEast,2004-02-03 21:17,264.9,107083,2004-02-20 03:37,winter storm
West,2002-06-19 13:39,391.4,378990,2002-06-19 14:27,equipment fault
```

Read Text File

Import the data using `readtable` and display the first five rows. The `readtable` function automatically detects the delimiter and the variable types.

```
T = readtable('outages.csv');
head(T,5)
```

Region	OutageTime	Loss	Customers	RestorationTime	Cause
{'SouthWest'}	2002-02-01 12:18	458.98	1.8202e+06	2002-02-07 16:50	{'winter st
{'SouthEast'}	2003-01-23 00:49	530.14	2.1204e+05	NaT	{'winter st
{'SouthEast'}	2003-02-07 21:15	289.4	1.4294e+05	2003-02-17 08:14	{'winter st
{'West'}	2004-04-06 05:44	434.81	3.4037e+05	2004-04-06 06:10	{'equipment
{'MidWest'}	2002-03-16 06:18	186.44	2.1275e+05	2002-03-18 23:23	{'severe st

Specify Variable Data Types Before Import

Updating the variable data types to the appropriate MATLAB® data types can benefit your data, based on the type of variables in your file. For example, the first and sixth columns in `outages.csv` are categorical. By designating these two columns as `categorical` arrays you can leverage MATLAB functions for processing categorical data.

Designate and specify the data types of the variables in one of these ways:

- Specify the `Format` name-value pair in `readtable`
- Set the `VariableTypes` property of the import options for the file

Use the `Format` name-value pair to specify the variable data types, read the data, and display the first five rows. In the `%{yyyy-MM-dd HH:mm}D` part of the `formatSpec` specifier, the text between the curly braces describes the format of the date and time data. The values specified in `Format` designate the:

- First and last columns in the file as categorical data
- Second and fifth columns as formatted date and time data
- Third and fourth columns as floating-point values

```
formatSpec = '%C%{yyyy-MM-dd HH:mm}D%f%f%{yyyy-MM-dd HH:mm}D%C';
T = readtable('outages.csv', 'Format', formatSpec);
head(T,5)
```

Region	OutageTime	Loss	Customers	RestorationTime	Cause
SouthWest	2002-02-01 12:18	458.98	1.8202e+06	2002-02-07 16:50	winter storm
SouthEast	2003-01-23 00:49	530.14	2.1204e+05	NaT	winter storm
SouthEast	2003-02-07 21:15	289.4	1.4294e+05	2003-02-17 08:14	winter storm
West	2004-04-06 05:44	434.81	3.4037e+05	2004-04-06 06:10	equipment fault
MidWest	2002-03-16 06:18	186.44	2.1275e+05	2002-03-18 23:23	severe storm

Alternatively, specify the data types for the variables by using the `setvartype` function of the `import` options. First, create an import options object for the file. The data file contains different types of variables. Designate the first and last variables as `categorical` arrays, the second and fifth variables as `datetime` arrays, and the remaining variables as `double`.

```
opts = detectImportOptions('outages.csv');
varNames = opts.VariableNames;
varTypes = {'categorical', 'datetime', 'double', ...
            'double', 'datetime', 'categorical'};
opts = setvartype(opts, varNames, varTypes);
```

Import the data using `readtable` with `opts`, and then display the first five rows.

```
T = readtable('outages.csv', opts);
head(T,5)
```

Region	OutageTime	Loss	Customers	RestorationTime	Cause
SouthWest	2002-02-01 12:18	458.98	1.8202e+06	2002-02-07 16:50	winter storm
SouthEast	2003-01-23 00:49	530.14	2.1204e+05	NaT	winter storm
SouthEast	2003-02-07 21:15	289.4	1.4294e+05	2003-02-17 08:14	winter storm
West	2004-04-06 05:44	434.81	3.4037e+05	2004-04-06 06:10	equipment fault
MidWest	2002-03-16 06:18	186.44	2.1275e+05	2002-03-18 23:23	severe storm

Append New Variable to Table

Table `T` contains `OutageTime` and `RestorationTime`. Calculate the duration of each electrical outage and append this data to the table.

```
T.Duration = T.RestorationTime - T.OutageTime;
head(T,5)
```

Region	OutageTime	Loss	Customers	RestorationTime	Cause
SouthWest	2002-02-01 12:18	458.98	1.8202e+06	2002-02-07 16:50	winter storm
SouthEast	2003-01-23 00:49	530.14	2.1204e+05	NaT	winter storm
SouthEast	2003-02-07 21:15	289.4	1.4294e+05	2003-02-17 08:14	winter storm

West	2004-04-06 05:44	434.81	3.4037e+05	2004-04-06 06:10	equipment fault
MidWest	2002-03-16 06:18	186.44	2.1275e+05	2002-03-18 23:23	severe storm

See Also

[readtimetable](#) | [readtable](#) | [detectImportOptions](#) | [setvaropts](#) | [setvartype](#) | [preview](#) | [head](#)

More About

- “Create Tables and Assign Data to Them”
- “Import Dates and Times from Text Files” on page 2-10
- “Access Data in Tables”

Import Block of Mixed Data from Text File into Table or Cell Array

This example reads a block of mixed text and numeric data from a text file, and then imports the block of data into a table or a cell array.

Data File Overview

The sample file `bigfile.txt` contains commented lines beginning with `##`. The data is arranged in five columns: The first column contains text indicating timestamps. The second, third, and fourth columns contain numeric data indicating temperature, humidity and wind speed. The last column contains descriptive text. Display the contents of the file `bigfile.txt`.

```
type('bigfile.txt')

## A    ID = 02476
## YKZ Timestamp Temp Humidity Wind Weather
06-Sep-2013 01:00:00    6.6    89    4    clear
06-Sep-2013 05:00:00    5.9    95    1    clear
06-Sep-2013 09:00:00    15.6   51    5    mainly clear
06-Sep-2013 13:00:00    19.6   37    10   mainly clear
06-Sep-2013 17:00:00    22.4   41    9    mostly cloudy
06-Sep-2013 21:00:00    17.3   67    7    mainly clear
## B    ID = 02477
## YVR Timestamp Temp Humidity Wind Weather
09-Sep-2013 01:00:00    15.2   91    8    clear
09-Sep-2013 05:00:00    19.1   94    7    n/a
09-Sep-2013 09:00:00    18.5   94    4    fog
09-Sep-2013 13:00:00    20.1   81    15   mainly clear
09-Sep-2013 17:00:00    20.1   77    17   n/a
09-Sep-2013 18:00:00    20.0   75    17   n/a
09-Sep-2013 21:00:00    16.8   90    25   mainly clear
## C    ID = 02478
## YYZ Timestamp Temp Humidity Wind Weather
```

Import Block of Data as Table

To import the data as a table, use `readtable` with import options.

Create an import options object for the file using the `detectImportOptions` function. Specify the location of the data using the `DataLines` property. For example, lines 3 through 8 contain the first block of data. Optionally, you can specify the names of the variables using the `VariableNames` property. Finally import the first block of data using `readtable` with the `opts` object.

```
opts = detectImportOptions('bigfile.txt');
opts.DataLines = [3 8];
opts.VariableNames = {'Timestamp','Temp',...
                     'Humidity','Wind','Weather'};
T_first = readtable('bigfile.txt',opts)

T_first=6x5 table
      Timestamp      Temp      Humidity      Wind      Weather
    _____  _____  _____  _____  _____
06-Sep-2013 01:00:00    6.6      89      4    {'clear' }
```

```

06-Sep-2013 05:00:00    5.9    95    1    {'clear'      }
06-Sep-2013 09:00:00   15.6    51    5    {'mainly clear' }
06-Sep-2013 13:00:00   19.6    37   10    {'mainly clear' }
06-Sep-2013 17:00:00   22.4    41    9    {'mostly cloudy'}
06-Sep-2013 21:00:00   17.3    67    7    {'mainly clear' }

```

Read the second block by updating the `DataLines` property to the location of the second block.

```

opts.DataLines = [11 17];
T_second = readtable('bigfile.txt',opts)

```

```

T_second=7x5 table
    Timestamp    Temp    Humidity    Wind    Weather
    _____    ____    _____    ____    _____
09-Sep-2013 01:00:00    15.2    91    8    {'clear'      }
09-Sep-2013 05:00:00    19.1    94    7    {'n/a'        }
09-Sep-2013 09:00:00    18.5    94    4    {'fog'        }
09-Sep-2013 13:00:00    20.1    81   15    {'mainly clear' }
09-Sep-2013 17:00:00    20.1    77   17    {'n/a'        }
09-Sep-2013 18:00:00    20    75   17    {'n/a'        }
09-Sep-2013 21:00:00    16.8    90   25    {'mainly clear' }

```

Import Block of Data as Cell Array

You can import the data as a cell array using the `readcell` function with `detectImportOptions`, or by using the `textscan` function. First import the block of data using the `readcell` function and then perform the same import by using `textscan`.

To perform the import using the `readcell` function, create an import options object for the file using the `detectImportOptions` function. Specify the location of the data using the `DataLines` property. Then, perform the import operation using the `readcell` function and import options object `opts`.

```

opts = detectImportOptions('bigfile.txt');
opts.DataLines = [3 8]; % first block of data
C = readcell('bigfile.txt',opts)

```

```

C=6x5 cell array
    {[06-Sep-2013 01:00:00]}    {[ 6.6000]}    {[89]}    {[ 4]}    {'clear'      }
    {[06-Sep-2013 05:00:00]}    {[ 5.9000]}    {[95]}    {[ 1]}    {'clear'      }
    {[06-Sep-2013 09:00:00]}    {[15.6000]}    {[51]}    {[ 5]}    {'mainly clear' }
    {[06-Sep-2013 13:00:00]}    {[19.6000]}    {[37]}    {[10]}    {'mainly clear' }
    {[06-Sep-2013 17:00:00]}    {[22.4000]}    {[41]}    {[ 9]}    {'mostly cloudy'}
    {[06-Sep-2013 21:00:00]}    {[17.3000]}    {[67]}    {[ 7]}    {'mainly clear' }

```

To perform the import using the `textscan` function, specify the size of block using `N` and the format of the data fields using `formatSpec`. For example, use `'%s'` for text variables, `'%D'` for date and time variables, or `'%c'` for categorical variables. Set the `'DateLocale'` name-value argument to `'en_US'` to ensure that the names of the months are interpreted in English. Use `fopen` to open the file. The function then returns a file identifier, `fileID`. Next, read from the file by using the `textscan` function.

```

N = 6;
formatSpec = '%D %f %f %f %c';
fileID = fopen('bigfile.txt');

```

Read the first block and display the contents of the variable Humidity.

```
C_first = textscan(fileID,formatSpec,N,'CommentStyle','##','Delimiter','\t','DateLocale','en_US')
```

```
C_first=1x5 cell array
    {6x1 datetime}    {6x1 double}    {6x1 double}    {6x1 double}    {6x1 char}
```

```
C_first{3}
```

```
ans = 6x1
```

```
    89
   NaN
    95
   NaN
    51
   NaN
```

Update the block size N, and read the second block. Display the contents of the fifth variable Weather.

```
N = 7;
```

```
C_second = textscan(fileID,formatSpec,N,'CommentStyle','##','Delimiter','\t','DateLocale','en_US')
```

```
C_second=1x5 cell array
    {7x1 datetime}    {7x1 double}    {7x1 double}    {7x1 double}    {7x1 char}
```

```
C_second{5}
```

```
ans = 7x1 char array
```

```
    'm'
    '←'
    'm'
    '←'
    'm'
    '←'
    'C'
```

Close the file.

```
fclose(fileID);
```

See Also

[readcell](#) | [readtable](#) | [textscan](#) | [fopen](#) | [detectImportOptions](#)

More About

- “Access Data in Cell Array”
- “Moving within a File” on page 4-10

Write Data to Text Files

In this section...

“Export Table to Text File” on page 2-22

“Export Cell Array to Text File” on page 2-23

“Export Numeric Array to Text File” on page 2-24

Export tabular data contained in tables, cell arrays, or numeric arrays from the MATLAB workspace to text files.

Export Table to Text File

You can export tabular data from MATLAB® workspace into a text file using the `writetable` function. Create a sample table, write the table to text file, and then write the table to text file with additional options.

Create a sample table, `T`, containing the variables `Pitch`, `Shape`, `Price` and `Stock`.

```
Pitch = [0.7;0.8;1;1.25;1.5];
Shape = {'Pan'; 'Round'; 'Button'; 'Pan'; 'Round'};
Price = [10.0;13.59;10.50;12.00;16.69];
Stock = [376;502;465;1091;562];
T = table(Pitch,Shape,Price,Stock)
```

```
T=5x4 table
   Pitch      Shape      Price      Stock
   -----
   0.7      {'Pan'  }      10      376
   0.8      {'Round'}     13.59    502
   1         {'Button'}    10.5     465
   1.25     {'Pan'  }      12      1091
   1.5     {'Round'}     16.69    562
```

Export the table, `T`, to a text file named `tabledata.txt`. View the contents of the file. By default, `writetable` writes comma-separated data, includes table variable names as column headings.

```
writetable(T,'tabledata.txt');
type tabledata.txt
```

```
Pitch,Shape,Price,Stock
0.7,Pan,10,376
0.8,Round,13.59,502
1,Button,10.5,465
1.25,Pan,12,1091
1.5,Round,16.69,562
```

Create a table `T2` which includes row names using the `RowNames` name-value pair argument.

```
rowNames = {'M4'; 'M5'; 'M6'; 'M8'; 'M10'};
T2 = table(Pitch,Shape,Price,Stock, 'RowNames', rowNames)
```

```
T2=5x4 table
      Pitch      Shape      Price      Stock
      _____  _____  _____  _____
M4      0.7      {'Pan'   }      10      376
M5      0.8      {'Round' }     13.59    502
M6       1      {'Button'}     10.5     465
M8     1.25      {'Pan'   }      12     1091
M10    1.5      {'Round' }     16.69    562
```

Export T2 to a tab-delimited text file named `tabledata2.txt`. Use the `Delimiter` name-value pair argument to specify a tab delimiter, and the `WriteRowNames` name-value pair argument to include row names. View the contents of the file.

```
writetable(T2,'tabledata2.txt','Delimiter','\t','WriteRowNames',true);
type tabledata2.txt
```

```
Row      Pitch      Shape      Price      Stock
M4      0.7      Pan      10      376
M5      0.8      Round    13.59    502
M6       1      Button   10.5     465
M8     1.25      Pan      12     1091
M10    1.5      Round    16.69    562
```

Export Cell Array to Text File

You can export a cell array from MATLAB® workspace into a text file in one of these ways:

- Use the `writecell` function to export the cell array to a text file.
- Use `fprintf` to export the cell array by specifying the format of the output data.

Create a sample cell array C.

```
C = {'Atkins',32,77.3,'M';'Cheng',30,99.8,'F';'Lam',31,80.2,'M'}
```

```
C = 3x4 cell array
    {'Atkins'}  {[32]}      {[77.3000]}  {'M'}
    {'Cheng' }  {[30]}      {[99.8000]}  {'F'}
    {'Lam'  }   {[31]}      {[80.2000]}  {'M'}
```

Export the cell array using `writecell`.

```
writecell(C,'data.dat')
```

View the contents of the file.

```
type data.dat
```

```
Atkins,32,77.3,M
Cheng,30,99.8,F
Lam,31,80.2,M
```

Alternatively, import the cell array using `fscanf`. Open a file that you can write to named `celldata.dat`. Define `formatSpec` using the format specifiers to describe the pattern of the data in

the file. Typical format specifiers include '%s' for a character vector, '%d' for an integer, or '%f' for a floating-point number. Separate each format specifier with a space to indicate a space delimiter for the output file. Include a newline character at the end of each row of data ('\n').

```
fileID = fopen('celldata.dat','w');
formatSpec = '%s %d %2.1f %s\n';
```

Determine the size of C and export one row of data at a time using the `fprintf` function. Then close the file. `fprintf` writes a space-delimited file.

```
[nrows,ncols] = size(C);
for row = 1:nrows
    fprintf(fileID,formatSpec,C{row,:});
end
fclose(fileID);
```

View the contents of the file.

```
type celldata.dat
```

```
Atkins 32 77.3 M
Cheng 30 99.8 F
Lam 31 80.2 M
```

Export Numeric Array to Text File

You can export a numerical array to a text file using `writematrix`.

Create a numeric array A.

```
A = magic(5)/10
```

```
A = 5×5
```

```
    1.7000    2.4000    0.1000    0.8000    1.5000
    2.3000    0.5000    0.7000    1.4000    1.6000
    0.4000    0.6000    1.3000    2.0000    2.2000
    1.0000    1.2000    1.9000    2.1000    0.3000
    1.1000    1.8000    2.5000    0.2000    0.9000
```

Write the numeric array to `myData.dat` and specify the delimiter to be ';'. Then, view the contents of the file.

```
writematrix(A,'myData.dat','Delimiter',';')
type myData.dat
```

```
1.7;2.4;0.1;0.8;1.5
2.3;0.5;0.7;1.4;1.6
0.4;0.6;1.3;2;2.2
1;1.2;1.9;2.1;0.3
1.1;1.8;2.5;0.2;0.9
```

See Also

`writematrix` | `writecell` | `writetimetable` | `fprintf` | `type` | `writetable`

Write to a Diary File

To keep an activity log of your MATLAB session, use the `diary` function. `diary` creates a verbatim copy of your MATLAB session in a disk file (excluding graphics).

For example, if you have the array `A` in your workspace,

```
A = [ 1 2 3 4; 5 6 7 8 ];
```

execute these commands at the MATLAB prompt to export this array using `diary`:

- 1 Turn on the `diary` function. Optionally, you can name the output file `diary` creates:

```
diary my_data.out
```

- 2 Display the contents of the array you want to export. This example displays the array `A`. You could also display a cell array or other MATLAB class:

```
A =  
    1    2    3    4  
    5    6    7    8
```

- 3 Turn off the `diary` function:

```
diary off
```

`diary` creates the file `my_data.out` and records all the commands executed in the MATLAB session until you turn it off:

```
A =  
    1    2    3    4  
    5    6    7    8
```

```
diary off
```

- 4 Open the `diary` file `my_data.out` in a text editor and remove the extraneous text, if desired.

Read Collection or Sequence of Text Files

When your data is stored across multiple text files, you can use `tabularTextDatastore` to manage and import the data. This example shows how to use `tabularTextDatastore` to read the data from the collection of text files all together, or to read one file at a time.

Data

For this example, the folder `C:\DataTxt` contains a collection of text files. Capture this location in the variable `location`. The data contains 10 text files, where each file contains 10 rows of data. The results differ based on your files and data.

```
location = 'C:\DataTxt';
dir(location)
```

```
.          File01.csv  File03.csv  File05.csv  File07.csv  File09.csv
..         File02.csv  File04.csv  File06.csv  File08.csv  File10.csv
```

Create Datastore

Create a datastore using the location of the files.

```
ds = tabularTextDatastore(location)
```

```
ds =
  TabularTextDatastore with properties:

          Files: {
                'C:\DataTxt\File01.csv';
                'C:\DataTxt\File02.csv';
                'C:\DataTxt\File03.csv'
                ... and 7 more
          }
  FileEncoding: 'UTF-8'
  AlternateFileSystemRoots: {}
  ReadVariableNames: true
  VariableNames: {'LastName', 'Gender', 'Age' ... and 7 more}
  DatetimeLocale: en_US

  Text Format Properties:
    NumHeaderLines: 0
    Delimiter: ','
    RowDelimiter: '\r\n'
    TreatAsMissing: ''
    MissingValue: NaN

  Advanced Text Format Properties:
    TextscanFormats: {'%q', '%q', '%f' ... and 7 more}
    TextType: 'char'
    ExponentCharacters: 'eEdD'
    CommentStyle: ''
    Whitespace: '\b\t'
    MultipleDelimitersAsOne: false

  Properties that control the table returned by preview, read, readall:
    SelectedVariableNames: {'LastName', 'Gender', 'Age' ... and 7 more}
```

```
SelectedFormats: {'%q', '%q', '%f' ... and 7 more}
ReadSize: 20000 rows
```

Read Data from Datastore

Use the `read` or `readall` functions to import the data from the datastore. If the data from the collection fits in the memory, you can import it all at once using the `readall` function.

```
allData = readall(ds);
size(allData)
```

```
ans = 1×2
    100    10
```

Alternatively, import the data one file at a time using the `read` function. To control the amount of data imported, before you call `read`, adjust the `ReadSize` property of the datastore. Set the `ReadSize` to `'file'` or a positive integer.

- If `ReadSize` is `'file'`, then each call to `read` reads all the data one file at a time.
- If `ReadSize` is a positive integer, then each call to `read` reads the number of rows specified by `ReadSize`, or fewer, if it reaches the end of the data.

```
ds.ReadSize = 'file';
firstFile = read(ds) % reads first file
```

```
firstFile=10×10 table
```

LastName	Gender	Age	Location	Height	Weight	Smoker
'Smith'	'Male'	38	'County General Hospital'	71	176	'TRUE'
'Johnson'	'Male'	43	'VA Hospital'	69	163	'FALSE'
'Williams'	'Female'	38	'St. Mary's Medical Center'	64	131	'FALSE'
'Jones'	'Female'	40	'VA Hospital'	67	133	'FALSE'
'Brown'	'Female'	49	'County General Hospital'	64	119	'FALSE'
'Davis'	'Female'	46	'St. Mary's Medical Center'	68	142	'FALSE'
'Miller'	'Female'	33	'VA Hospital'	64	142	'TRUE'
'Wilson'	'Male'	40	'VA Hospital'	68	180	'FALSE'
'Moore'	'Male'	28	'St. Mary's Medical Center'	68	183	'FALSE'
'Taylor'	'Female'	31	'County General Hospital'	66	132	'FALSE'

```
secondFile = read(ds) % reads second file
```

```
secondFile=10×10 table
```

LastName	Gender	Age	Location	Height	Weight	Smoker
'Anderson'	'Female'	45	'County General Hospital'	68	128	'FALSE'
'Thomas'	'Female'	42	'St. Mary's Medical Center'	66	137	'FALSE'
'Jackson'	'Male'	25	'VA Hospital'	71	174	'FALSE'
'White'	'Male'	39	'VA Hospital'	72	202	'TRUE'
'Harris'	'Female'	36	'St. Mary's Medical Center'	65	129	'FALSE'
'Martin'	'Male'	48	'VA Hospital'	71	181	'TRUE'
'Thompson'	'Male'	32	'St. Mary's Medical Center'	69	191	'TRUE'
'Garcia'	'Female'	27	'VA Hospital'	69	131	'TRUE'

'Martinez'	'Male'	37	'County General Hospital'	70	179	'FALSE'
'Robinson'	'Male'	50	'County General Hospital'	68	172	'FALSE'

See Also

[readtable](#) | [readmatrix](#) | [readcell](#) | [readvars](#) | [readtimetable](#) | [tabularTextDatastore](#)

More About

- “Read and Analyze Large Tabular Text File” on page 13-98

Import Block of Numeric Data from Text File

This example shows how to read numeric data organized in blocks in a text file. Each block within the file can have a different format. You can read all the blocks as cell arrays, one block at a time, using `textscan`.

File Format Overview

The information in the sample text file, `test80211.txt`, is the result from a wireless network communication quality test. The sample file consists of four lines of introduction followed by several blocks of data. Each block represents a different environment (for example, mobile, indoor, outdoor) and has the following format:

- Two header lines of description
- The text, `Num SNR=`, followed by a numeric value, `m`
- Numeric data organized in a table of `m` columns and an arbitrary number of rows (The data is comma-delimited.)
- The text, `*EOB`, denoting the end of the block

For example, a block of data is formatted like this:

```
* Indoor2
* SNR Vs test No
Num SNR=3
,-5.00E+00,-4.00E+00,
1.00E+00,3.32E-07,9.12E-07
2.00E+00,1.49E-07,2.44E-07
3.00E+00,6.04E-07,2.53E-07
4.00E+00,1.53E-07,4.25E-07
5.00E+00,1.82E-07,1.83E-07
6.00E+00,6.27E-07,8.21E-07
7.00E+00,9.10E-08,1.53E-08
8.00E+00,8.73E-07,6.45E-07
9.00E+00,4.40E-07,1.33E-07
*EOB
```

The numeric data represents error rates over a range of noise levels for a number of independent tests. The first column indicates the test number. To view the entire sample file, type at the command line:

```
open test80211.txt
```

Open Text File for Reading

Open the file and create a file identifier.

```
fileID = fopen('test80211.txt','r');
```

Read Introduction Lines

Read the four introductory lines, which contain text delimited by a newline character. `textscan` returns a 1-by-1 cell array containing a 4-by-1 cell array of character vectors.

```
Intro = textscan(fileID, '%s', 4, 'Delimiter', '\n')
```

```
Intro = 1x1 cell array
        {4x1 cell}
```

View the contents of the first cell.

```
disp(Intro{1})

{'*CCX'
 '*CCX WiFi conformance test'}
{'*CCX BER Results'
 '*CCX'}
```

Read Each Block

For each block, we want to read a header, the numeric value `m`, column headers for the data, then the data itself. First, initialize the block index.

```
Block = 1;
```

Read each block of data in a `while` loop. The loop executes until the end of the file is reached and `~feof` returns `false`. The `textscan` function returns the data in each block as a cell array named `InputText`. Convert each cell array to a numeric array using `cell2mat` and store the numeric array in a cell array named `Data`. A cell array allows the storage of different size blocks.

```
while (~feof(fileID)) % For each block:

    fprintf('Block: %s\n', num2str(Block)) % Print block number to the screen
    InputText = textscan(fileID, '%s', 2, 'delimiter', '\n'); % Read 2 header lines
    HeaderLines{Block,1} = InputText{1};
    disp(HeaderLines{Block}); % Display header lines

    InputText = textscan(fileID, 'Num SNR = %f'); % Read the numeric value
    NumCols = InputText{1}; % following the text, Num SNR =
    % Specify that this is the
    % number of data columns

    FormatString = repmat('%f', 1, NumCols); % Create format string
    % based on the number
    % of columns
    InputText = textscan(fileID, FormatString, ... % Read data block
        'delimiter', ',');

    Data{Block,1} = cell2mat(InputText);
    [NumRows, NumCols] = size(Data{Block}); % Determine size of table
```

```
disp(cellstr(['Table data size: ' ...
             num2str(NumRows) ' x ' num2str(NumCols)]));
disp(' '); % New line

eob = textscan(fileID,'%s',1,'delimiter','\n'); % Read and discard end-of-block marker
Block = Block+1; % Increment block index
end

Block: 1

{*      Mobile1      }
{*      SNR Vs test No'}

{'Table data size: 30 x 19'}

Block: 2

{*      Mobile2      }
{*      SNR Vs test No'}

{'Table data size: 30 x 9'}

Block: 3

{*      Mobile3      }
{*      SNR Vs test No'}

{'Table data size: 31 x 15'}

Block: 4

{*      Mobile4      }
{*      SNR Vs test No'}

{'Table data size: 28 x 19'}

Block: 5

{*      Mobile5      }
{*      SNR Vs test No'}

{'Table data size: 32 x 18'}

Block: 6

{*      Mobile6      }
{*      SNR Vs test No'}

{'Table data size: 30 x 19'}

Block: 7
```



```
{'*      Mobile7'      }  
{'*      SNR Vs test No'}  
  
{'Table data size: 30 x 11'}
```

Block: 8

```
{'*      Mobile8'      }  
{'*      SNR Vs test No'}  
  
{'Table data size: 20 x 18'}
```

Block: 9

```
{'*      Indoor0'      }  
{'*      SNR Vs test No'}  
  
{'Table data size: 9 x 3'}
```

Block: 10

```
{'*      Indoor1'      }  
{'*      SNR Vs test No'}  
  
{'Table data size: 22 x 6'}
```

Block: 11

```
{'*      Indoor2'      }  
{'*      SNR Vs test No'}  
  
{'Table data size: 25 x 3'}
```

Block: 12

```
{'*      Indoor3'      }  
{'*      SNR Vs test No'}  
  
{'Table data size: 21 x 18'}
```

Block: 13

```
{'*      Outdoor1'     }  
{'*      SNR Vs test No'}  
  
{'Table data size: 20 x 18'}
```

Block: 14

```
{'*      Outdoor2'      }
{'*      SNR Vs test No'}

{'Table data size: 23 x 3'}
```

Block: 15

```
{'*      Outdoor3'      }
{'*      SNR Vs test No'}

{'Table data size: 22 x 18'}
```

Block: 16

```
{'*      Outdoor4'      }
{'*      SNR Vs test No'}

{'Table data size: 21 x 18'}
```

Block: 17

```
{'*      Outdoor5'      }
{'*      SNR Vs test No'}

{'Table data size: 18 x 5'}
```

Close Text File

```
fclose(fileID);
```

Total Number of Blocks

Determine the number of blocks in the file.

```
NumBlocks = Block-1
```

```
NumBlocks = 17
```

View Numeric Data

Display the numeric data in one of the blocks using short scientific notation.

First, store the current Command Window output display format.

```
user_format = get(0, 'format');
```

Change the display format to short scientific notation.

```
format shortE
```

Display the header lines for the ninth block and the numeric data.

```
Block = 9;
disp(HeaderLines{Block});
```

```
{'*      Indoor0'      }
{'*      SNR Vs test No'}

fprintf('SNR      %d      %d\n',Data{Block,1}(1,2:end))
SNR      -7      -6

disp(Data{Block,1}(2:end,2:end));

9.0600e-07  6.7100e-07
3.1700e-07  3.5400e-07
2.8600e-07  1.9600e-07
1.4800e-07  7.3400e-07
3.9500e-08  9.6600e-07
7.9600e-07  7.8300e-07
4.0000e-07  8.8100e-07
3.0100e-07  2.9700e-07
```

Restore the original Command Window output display format.

```
set(0, 'format', user_format);
```

See Also

textscan

More About

- “Import Block of Mixed Data from Text File into Table or Cell Array” on page 2-19

Spreadsheets

- “Import Spreadsheets” on page 3-2
- “Read Spreadsheet Data Using Import Tool” on page 3-4
- “Read Spreadsheet Data into Array or Individual Variables” on page 3-7
- “Read Spreadsheet Data into Table” on page 3-9
- “Read Collection or Sequence of Spreadsheet Files” on page 3-12
- “Write Data to Excel Spreadsheets” on page 3-15
- “Define Import Options for Tables” on page 3-18

Import Spreadsheets

Spreadsheets often contain a mix of numeric and text data as well as variable and row names, which is best represented in MATLAB as a table. You can import data into a table using the **Import Tool** or the `readtable` function.

Import Spreadsheet Data Using the Import Tool

The **Import Tool** allows you to import into a table or other data type. For example, read data from the sample spreadsheet file `patients.xls` as a table in MATLAB. Open the file using the **Import Tool** and select options such as the range of data and the output type. Then, click the **Import**

Selection button  to import the data into the MATLAB workspace.

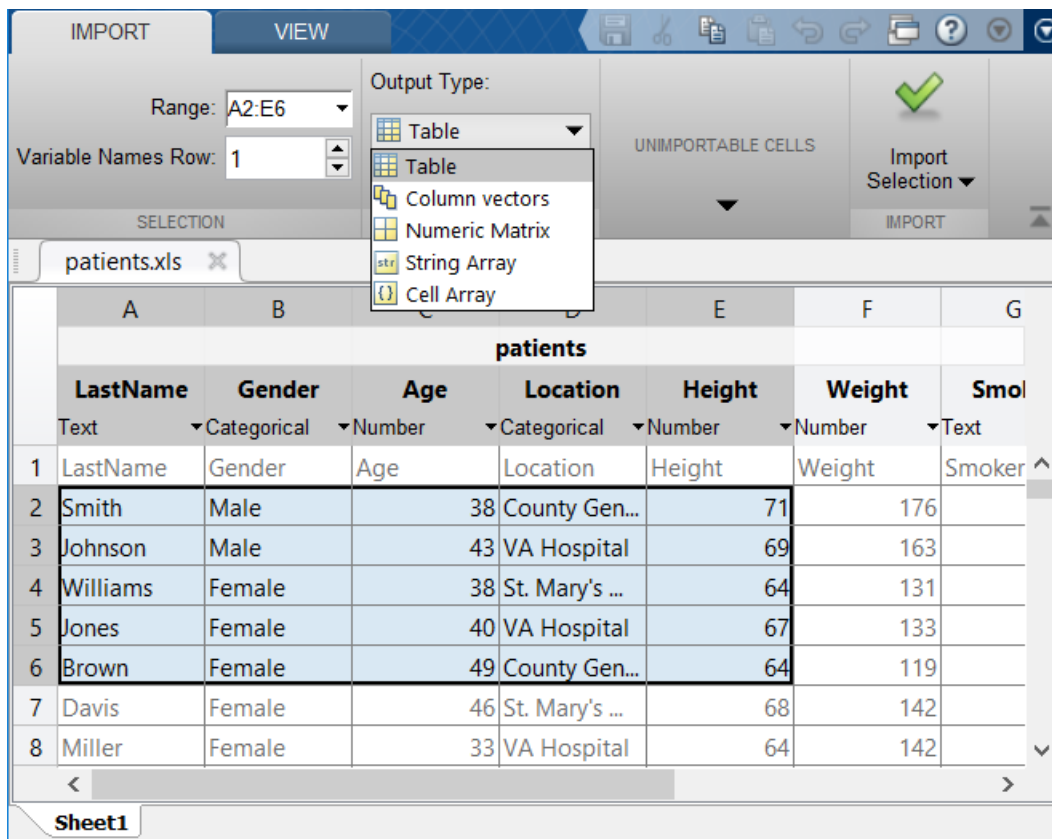

patients						
LastName	Gender	Age	Location	Height	Weight	Smoker
Text	Categorical	Number	Categorical	Number	Number	Text
1	LastName	Gender	Age	Location	Height	Smoker
2	Smith	Male	38	County Gen...	71	176
3	Johnson	Male	43	VA Hospital	69	163
4	Williams	Female	38	St. Mary's ...	64	131
5	Jones	Female	40	VA Hospital	67	133
6	Brown	Female	49	County Gen...	64	119
7	Davis	Female	46	St. Mary's ...	68	142
8	Miller	Female	33	VA Hospital	64	142

Import Spreadsheet Data Using readtable

Alternatively, you can read spreadsheet data into a table using the `readtable` function with the file name, for example:

```
T = readtable('patients.xls');
```

You can also select the range of data to import by specifying the range parameter. For example, read the first five rows and columns of the spreadsheet. Specify the range in Excel notation as 'A1:E5'.

```
T = readtable('patients.xls', 'Range', 'A1:E5')
```

T =

4x5 table

LastName	Gender	Age	Location	Height
{'Smith' }	{'Male' }	38	{'County General Hospital' }	71
{'Johnson' }	{'Male' }	43	{'VA Hospital' }	69
{'Williams' }	{'Female' }	38	{'St. Mary's Medical Center' }	64
{'Jones' }	{'Female' }	40	{'VA Hospital' }	67

Import Spreadsheet Data as Other Data Types

In addition to tables, you can import your spreadsheet data into the MATLAB workspace as a timetable, a numeric matrix, a cell array, or separate column vectors. Based on the data type you need, use one of these functions.

Data Type of Output	Function
Timetable	readtimetable
Numeric Matrix	readmatrix
Cell Array	readcell
Separate Column Vectors	readvars

See Also

Import Tool | readtable

More About

- “Read Spreadsheet Data Using Import Tool” on page 3-4
- “Read Spreadsheet Data into Table” on page 3-9
- “Access Data in Tables”

Read Spreadsheet Data Using Import Tool

In this section...

“Select Data Interactively” on page 3-4

“Import Data from Multiple Spreadsheets” on page 3-5

“Paste Data from Clipboard” on page 3-6

This example shows how to import data from a spreadsheet into the workspace using the Import Tool and also to import data from the clipboard.

Select Data Interactively

On the **Home** tab, in the **Variable** section, click **Import Data** . Alternatively, in the Current Folder browser, double-click the name of a file with an extension of `.xls`, `.xlsx`, `.xlsb`, or `.xlm`. The Import Tool opens.

Select the data you want to import. For example, the data in the following figure corresponds to data for three column vectors. You can edit the variable name within the tab, and you can select noncontiguous sections of data for the same variable.

	A Station Number	B Temp Number	C Date Datetime
1	Station	Temp	Date
2	12	Replaced by:NaN	13
3	13	NaN	10/23/2013
4	14	97	12/1/2013

On the **Import** tab, in the **Output Type** section, select how you want the data to be imported. The option you select dictates the data type of the imported data.

Option Selected	How Data Is Imported
Column vectors	Import each column of the selected data as an individual m-by-1 vector.
Numeric Matrix	Import selected data as an m-by-n numeric array.
String Array	Import selected data as an m-by-n string array.
Cell Array	Import selected data as a cell array that can contain multiple data types, such as numeric data and text.
Table	Import selected data as a table.

If you choose to import the data as a matrix or as numeric column vectors, the tool highlights any nonnumeric data in the worksheet. Each highlight color corresponds to a proposed rule to make the data fit into a numeric array. For example, you can replace nonnumeric values with NaN. Also, you can see how your data will be imported when you place the cursor over individual cells.

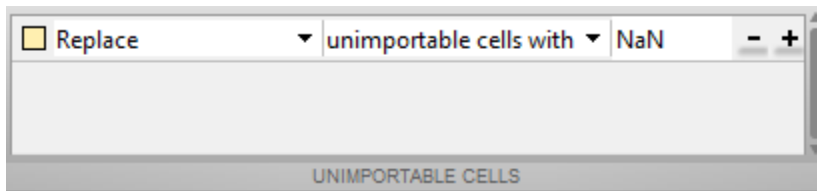

You can add, remove, reorder, or edit rules, such as changing the replacement value from NaN to another value. All rules apply to the imported data only and do not change the data in the file. Specify rules any time the range includes nonnumeric data and you are importing into a matrix or numeric column vectors.

Any cells that contain #Error? correspond to formula errors in your spreadsheet file, such as division by zero. The Import Tool regards these cells as nonnumeric.

When you click the **Import Selection** button , the Import Tool creates variables in your workspace.

For more information on interacting with the Import Tool, watch this video.

Import Data from Multiple Spreadsheets

If you plan to perform the same import operation on multiple files, you can generate code from the Import Tool to make it easier to repeat the operation. On all platforms, the Import Tool can generate a program script that you can edit and run to import the files. On Microsoft Windows systems with Excel software, the Import Tool can generate a function that you can call for each file.

For example, suppose that you have a set of spreadsheets in the current folder named myfile01.xlsx through myfile25.xlsx, and you want to import the same range of data, A2:G100, from the first worksheet in each file. Generate code to import the entire set of files as follows:

- 1 Open one of the files in the Import Tool.
- 2 From the **Import Selection** button, select **Generate Function**. The Import Tool generates code similar to the following excerpt, and opens the code in the Editor.

```
function data = importfile(workbookFile, sheetName, range)
%IMPORTFILE Import numeric data from a spreadsheet
...
```

- 3 Save the function.
- 4 In a separate program file or at the command line, create a **for** loop to import data from each spreadsheet into a cell array named myData:

```
numFiles = 25;
range = 'A2:G100';
sheet = 1;
myData = cell(1,numFiles);

for fileNum = 1:numFiles
    fileName = sprintf('myfile%02d.xlsx',fileNum);
    myData{fileNum} = importfile(fileName,sheet,range);
end
```

Each cell in `myData` contains an array of data from the corresponding worksheet. For example, `myData{1}` contains the data from the first file, `myfile01.xlsx`.

Paste Data from Clipboard

In addition to importing data interactively, you can also paste spreadsheet data from the clipboard into MATLAB.

First, select and copy your spreadsheet data in Microsoft Excel, then use one of the following methods:

- On the Workspace browser title bar, click , and then select **Paste**.
- Open an existing variable in the Variables editor, right-click, and then select **Paste Excel Data**.
- Call `uiimport -pastespecial`.

See Also

`readmatrix` | `readcell` | `readvars` | `readtable` | `detectImportOptions`

More About

- “Define Import Options for Tables” on page 3-18
- “Read Spreadsheet Data into Array or Individual Variables” on page 3-7

Read Spreadsheet Data into Array or Individual Variables

The best way to represent spreadsheet data in MATLAB® is in a table, which can store a mix of numeric and text data. However, sometimes you need to import spreadsheet data as a matrix, a cell array, or separate variables. Based on your data and the data type you need in the MATLAB® workspace, use one of these functions:

- `readmatrix` — Import homogeneous numeric or text data as a matrix.
- `readcell` — Import mixed numeric and text data as a cell array.
- `readvars` — Import spreadsheet columns as separate variables.

Read Spreadsheet Data into Matrix

Import numeric data from `basic_matrix.xls` into a matrix.

```
M = readmatrix('basic_matrix.xls')
```

```
M = 5×4
```

```

     6     8     3     1
     5     4     7     3
     1     6     7    10
     4     2     8     2
     2     7     5     9

```

You can also select the data to import from the spreadsheet by specifying the `Sheet` and `Range` parameters. For example, specify the `Sheet` parameter as `'Sheet1'` and the `Range` parameter as `'B1:D3'`. The `readmatrix` function reads a 3-by-3 subset of the data, starting at the element in the first row and second column of the sheet named `'Sheet1'`.

```
M = readmatrix('basic_matrix.xls','Sheet','Sheet1','Range','B1:D3')
```

```
M = 3×3
```

```

     8     3     1
     4     7     3
     6     7    10

```

Read Spreadsheet Data into Cell Array

Import the mixed tabular data from `airlinesmall_subset.xlsx` into a cell array.

```
C = readcell('airlinesmall_subset.xlsx');
```

```
whos C
```

Name	Size	Bytes	Class	Attributes
C	1339×29	4277290	cell	

You can also select the data to import from the spreadsheet by specifying the `Sheet` and `Range` parameters. For example, specify the `Sheet` parameter as `'2007'` and the `Range` parameter as `'G2:I11'`. The `readcell` function imports ten rows of data for variables in columns 7, 8, and 9, from the worksheet named `'2007'`.

```
subC = readcell('airlinesmall_subset.xlsx', 'Sheet', '2007', 'Range', 'G2:I11')
```

```
subC=10x3 cell array
    {[ 935]}    {[ 935]}    {'WN'}
    {[1041]}    {[1040]}    {'WN'}
    {[1430]}    {[1500]}    {'WN'}
    {[ 940]}    {[ 950]}    {'WN'}
    {[1515]}    {[1515]}    {'WN'}
    {[2042]}    {[2035]}    {'WN'}
    {[2116]}    {[2130]}    {'WN'}
    {[1604]}    {[1605]}    {'WN'}
    {[1258]}    {[1230]}    {'WN'}
    {[1134]}    {[1145]}    {'WN'}
```

Read Spreadsheet Data Columns as Separate Variables

Import the first three columns from `airlinesmall_subset.xlsx` as separate workspace variables.

```
[Year,Month,DayOfMonth] = readvars('airlinesmall_subset.xlsx');
whos Year Month DayOfMonth
```

Name	Size	Bytes	Class	Attributes
DayOfMonth	1338x1	10704	double	
Month	1338x1	10704	double	
Year	1338x1	10704	double	

You can also select which subset to import from the spreadsheet by specifying the `Sheet` and `Range` parameters. For example, import ten rows of the column `DayOfMonth` from the worksheet named `'2004'`. Specify the column and number of rows using the `Range` parameter.

```
DayOfMonth = readvars('airlinesmall_subset.xlsx', 'Sheet', '2004', 'Range', 'C2:C11')
```

```
DayOfMonth = 10x1
```

```
26
10
21
24
20
20
1
2
30
11
```

See Also

`readtable` | `readmatrix` | `readcell` | `readvars`

More About

- “Read Spreadsheet Data Using Import Tool” on page 3-4
- “Read Spreadsheet Data into Table” on page 3-9
- “Read Collection or Sequence of Spreadsheet Files” on page 3-12

Read Spreadsheet Data into Table

The best way to represent spreadsheet data in MATLAB® is in a table, which can store a mix of numeric and text data, as well as variable and row names. You can read data into tables interactively or programmatically. To interactively select data, click **Import Data** on the **Home** tab, in the **Variable** section. To programmatically import data, use one of these functions:

- `readtable` — Read a single worksheet.
- `spreadsheetDatastore` — Read multiple worksheets or files.

This example shows how to import spreadsheet data programmatically using both functions. The sample data, `airlinesmall_subset.xlsx`, contains one sheet for each year between 1996 and 2008. The sheet names correspond to the year, such as `2003`.

Read All Data from Worksheet

Call `readtable` to read all the data in the worksheet called `2008`, and then display only the first 10 rows and columns. Specify the worksheet name using the `Sheet` name-value pair argument. If your data is on the first worksheet in the file, you do not need to specify `Sheet`.

```
T = readtable('airlinesmall_subset.xlsx', 'Sheet', '2008');
T(1:10, 1:10)
```

```
ans=10x10 table
   Year   Month   DayOfMonth   DayOfWeek   DepTime   CRSDepTime   ArrTime   CRSArrTime
   _____   _____   _____   _____   _____   _____   _____   _____
   2008     1         3           4           1012       1010         1136       1135
   2008     1         4           5           1303       1300         1411       1415
   2008     1         6           7           2134       2115         2242       2220
   2008     1         7           1           1734       1655         54         30
   2008     1         8           2           1750       1755         2018       2035
   2008     1         9           3           640        645         855        905
   2008     1        10           4           1943       1945         2039       2040
   2008     1        11           5           1303       1305         1401       1400
   2008     1        13           7           1226       1230         1415       1400
   2008     1        14           1           1337       1340         1623       1630
```

Read Selected Range from Specific Worksheet

From the worksheet named `1996`, read only 10 rows of data from the first 5 columns by specifying a range, `'A1:E11'`. The `readtable` function returns a 10-by-5 table.

```
T_selected = readtable('airlinesmall_subset.xlsx', 'Sheet', '1996', 'Range', 'A1:E11')
```

```
T_selected=10x5 table
   Year   Month   DayOfMonth   DayOfWeek   DepTime
   _____   _____   _____   _____   _____
   1996     1        18           4           2117
   1996     1        12           5           1252
   1996     1        16           2           1441
   1996     1         1           1           2258
   1996     1         4           4           1814
```

1996	1	31	3	1822
1996	1	18	4	729
1996	1	26	5	1704
1996	1	11	4	1858
1996	1	7	7	2100

Convert Variables to Datetimes, Durations, or Categoricals

During the import process, `readtable` automatically detects the data types of the variables. However, if your data contains nonstandard dates, durations, or repeated labels, then you can convert those variables to their correct data types. Converting variables to their correct data types lets you perform efficient computations and comparisons and improves memory usage. For instance, represent the variables `Year`, `Month`, and `DayofMonth` as one `datetime` variable, the `UniqueCarrier` as `categorical`, and `ArrDelay` as duration in minutes.

```
data = T(:, {'Year', 'Month', 'DayofMonth', 'UniqueCarrier', 'ArrDelay'});
data.Date = datetime(data.Year, data.Month, data.DayofMonth);
data.UniqueCarrier = categorical(data.UniqueCarrier);
data.ArrDelay = minutes(data.ArrDelay);
```

Find the day of the year with the longest delay, and then display the date.

```
ind = find(data.ArrDelay == max(data.ArrDelay));
data.Date(ind)
```

```
ans = datetime
    07-Apr-2008
```

Read All Worksheets from Spreadsheet File

A datastore is useful for processing arbitrarily large amounts of data that are spread across multiple worksheets or multiple spreadsheet files. You can perform data import and data processing through the datastore.

Create a datastore from the collection of worksheets in `airlinesmall_subset.xlsx`, select the variables to import, and then preview the data.

```
ds = spreadsheetDatastore('airlinesmall_subset.xlsx');
ds.SelectedVariableNames = {'Year', 'Month', 'DayofMonth', 'UniqueCarrier', 'ArrDelay'};
preview(ds)
```

```
ans=8x5 table
   Year   Month   DayofMonth   UniqueCarrier   ArrDelay
   _____   _____   _____   _____   _____
   1996     1         18           {'HP'}           6
   1996     1         12           {'HP'}           11
   1996     1         16           {'HP'}          -13
   1996     1          1           {'HP'}            1
   1996     1          4           {'US'}           -9
   1996     1         31           {'US'}            9
   1996     1         18           {'US'}           -2
   1996     1         26           {'NW'}          -10
```

Before importing data, you can specify what data types to use. For this example, import `UniqueCarrier` as a categorical variable.

```
ds.SelectedVariableTypes(4) = {'categorical'};
```

Import data using the `readall` or `read` functions. The `readall` function requires that all the data fit into memory, which is true for the sample data. After the import, compute the maximum arrival delay for this dataset.

```
alldata = readall(ds);  
max(alldata.ArrDelay)/60  
  
ans = 15.2333
```

For large data sets, import portions of the file using the `read` function. For more information, see **Read Collection or Sequence of Spreadsheet Files**.

See Also

`readtable` | `spreadsheetDatastore`

More About

- “Read Spreadsheet Data Using Import Tool” on page 3-4
- “Read Spreadsheet Data into Array or Individual Variables” on page 3-7
- “Read Collection or Sequence of Spreadsheet Files” on page 3-12

Read Collection or Sequence of Spreadsheet Files

When you have data stored across multiple spreadsheet files, use `spreadsheetDatastore` to manage and import the data. After creating the datastore, you can read all the data from the collection simultaneously, or you can read one file at a time.

Data

If the folder `C:\Data` contains a collection of spreadsheet files, then capture the location of the data in `location`. The data used in this example contains 10 spreadsheet files, where each file contains 10 rows of data. Your results will differ based on your files and data.

```
location = 'C:\Data';
dir(location)
```

```
.          ..          File01.xls  File02.xls  File03.xls  File04.xls  File05.xls  File06.xls  I
```

Create Datastore

Create a datastore using the location of the files.

```
ds = spreadsheetDatastore(location)
```

```
ds =
```

```
SpreadsheetDatastore with properties:
```

```

    Files: {
        'C:\Data\File01.xls';
        'C:\Data\File02.xls';
        'C:\Data\File03.xls'
        ... and 7 more
    }
    AlternateFileSystemRoots: {}
    Sheets: ''
    Range: ''

    Sheet Format Properties:
        NumHeaderLines: 0
        ReadVariableNames: true
        VariableNames: {'LastName', 'Gender', 'Age' ... and 7 more}
        VariableTypes: {'char', 'char', 'double' ... and 7 more}

    Properties that control the table returned by preview, read, readall:
        SelectedVariableNames: {'LastName', 'Gender', 'Age' ... and 7 more}
        SelectedVariableTypes: {'char', 'char', 'double' ... and 7 more}
        ReadSize: 'file'
```

Read Data from Datastore

Use the `read` or `readall` functions to import the data from the datastore. If the data from the collection fits in the memory, then you can import it all at once using the `readall` function.

```
allData = readall(ds);
size(allData)
```



```
ans = 1x2
    100    10
```

Alternatively, you can import the data one file at a time using the `read` function. To control the amount of data imported, before you call `read`, adjust the `ReadSize` property of the datastore. You can set the `ReadSize` to `'file'`, `'sheet'`, or a positive integer.

- If `ReadSize` is `'file'`, then each call to `read` returns data one file at a time.
- If `ReadSize` is `'sheet'`, then each call to `read` returns data one sheet at a time.
- If `ReadSize` is a positive integer, then each call to `read` returns the number of rows specified by `ReadSize`, or fewer if it reaches the end of the data.

```
ds.ReadSize = 'file';
firstFile = read(ds) % reads first file
```

```
firstFile=10x10 table
```

LastName	Gender	Age	Location	Height	Weight	Smoker
'Smith'	'Male'	38	'County General Hospital'	71	176	'true'
'Johnson'	'Male'	43	'VA Hospital'	69	163	'false'
'Williams'	'Female'	38	'St. Mary's Medical Center'	64	131	'false'
'Jones'	'Female'	40	'VA Hospital'	67	133	'false'
'Brown'	'Female'	49	'County General Hospital'	64	119	'false'
'Davis'	'Female'	46	'St. Mary's Medical Center'	68	142	'false'
'Miller'	'Female'	33	'VA Hospital'	64	142	'true'
'Wilson'	'Male'	40	'VA Hospital'	68	180	'false'
'Moore'	'Male'	28	'St. Mary's Medical Center'	68	183	'false'
'Taylor'	'Female'	31	'County General Hospital'	66	132	'false'

```
secondFile = read(ds) % reads second file
```

```
secondFile=10x10 table
```

LastName	Gender	Age	Location	Height	Weight	Smoker
'Anderson'	'Female'	45	'County General Hospital'	68	128	'false'
'Thomas'	'Female'	42	'St. Mary's Medical Center'	66	137	'false'
'Jackson'	'Male'	25	'VA Hospital'	71	174	'false'
'White'	'Male'	39	'VA Hospital'	72	202	'true'
'Harris'	'Female'	36	'St. Mary's Medical Center'	65	129	'false'
'Martin'	'Male'	48	'VA Hospital'	71	181	'true'
'Thompson'	'Male'	32	'St. Mary's Medical Center'	69	191	'true'
'Garcia'	'Female'	27	'VA Hospital'	69	131	'true'
'Martinez'	'Male'	37	'County General Hospital'	70	179	'false'
'Robinson'	'Male'	50	'County General Hospital'	68	172	'false'

See Also

[readtable](#) | [spreadsheetDatastore](#)

More About

- “Read Spreadsheet Data into Table” on page 3-9

Write Data to Excel Spreadsheets

In this section...

“Write Tabular Data to Spreadsheet File” on page 3-15

“Write Numeric and Text Data to Spreadsheet File” on page 3-15

“Disable Warning When Adding New Worksheet” on page 3-16

“Format Cells in Excel Files” on page 3-16

Write Tabular Data to Spreadsheet File

To export a table in the workspace to a Microsoft® Excel® spreadsheet file, use the `writetable` function. You can export data from the workspace to any worksheet in the file, and to any location within that worksheet. By default, `writetable` writes your table data to the first worksheet in the file, starting at cell A1.

For example, create a sample table of column-oriented data and display the first five rows.

```
load patients.mat
T = table(LastName, Age, Weight, Smoker);
T(1:5, :)
```

ans=5×4 table

LastName	Age	Weight	Smoker
{'Smith' }	38	176	true
{'Johnson' }	43	163	false
{'Williams' }	38	131	false
{'Jones' }	40	133	false
{'Brown' }	49	119	false

Write table T to the first sheet in a new spreadsheet file named `patientdata.xlsx`, starting at cell D1. To specify the portion of the worksheet you want to write to, use the Range name-value pair argument. By default, `writetable` writes the table variable names as column headings in the spreadsheet file.

```
filename = 'patientdata.xlsx';
writetable(T, filename, 'Sheet', 1, 'Range', 'D1')
```

Write the table T without the variable names to a new sheet called 'MyNewSheet'. To write the data without the variable names, specify the name-value pair `WriteVariableNames` as `false`.

```
writetable(T, filename, 'Sheet', 'MyNewSheet', 'WriteVariableNames', false);
```

Write Numeric and Text Data to Spreadsheet File

To export a numeric array and a cell array to a Microsoft Excel spreadsheet file, use the `writematrix` or `writecell` functions. You can export data in individual numeric and text workspace variables to any worksheet in the file, and to any location within that worksheet. By

default, the import functions write your matrix data to the first worksheet in the file, starting at cell A1.

For example, create a sample array of numeric data, A, and a sample cell array of text and numeric data, C.

```
A = magic(5)
C = {'Time', 'Temp'; 12 98; 13 'x'; 14 97}
```

A =

```
17    24     1     8    15
23     5     7    14    16
 4     6    13    20    22
10    12    19    21     3
11    18    25     2     9
```

C =

```
'Time'    'Temp'
[ 12]     [ 98]
[ 13]     ['x']
[ 14]     [ 97]
```

Write array A to the 5-by-5 rectangular region, E1:I5, on the first sheet in a new spreadsheet file named `testdata.xlsx`.

```
filename = 'testdata.xlsx';
writematrix(A,filename,'Sheet',1,'Range','E1:I5')
```

Write cell array C to a rectangular region that starts at cell B2 on a worksheet named Temperatures. You can specify range using only the first cell.

```
writecell(C,filename,'Sheet','Temperatures','Range','B2');
```

`writecell` displays a warning because the worksheet, Temperatures, did not previously exist, but you can disable this warning.

Disable Warning When Adding New Worksheet

If the target worksheet does not exist in the file, then the `writetable` and `writecell` functions display this warning:

```
Warning: Added specified worksheet.
```

For information on how to suppress warning messages, see “Suppress Warnings”.

Format Cells in Excel Files

To write data to Excel files on Windows systems with custom formats (such as fonts or colors), access the COM server directly using `actxserver` rather than `writetable`, `writetimetable`, `writematrix`, or `writecell`. For example, Technical Solution 1-QLD4K uses `actxserver` to establish a connection between MATLAB and Excel, write data to a worksheet, and specify the colors of the cells.

For more information, see “Get Started with COM”.

See Also

writematrix | writecell | writetable

Define Import Options for Tables

Typically, you can import tables using the `readtable` function. However, sometimes importing tabular data requires additional control over the import process. For example, you might want to select the variables to import or handle rows with missing or error-causing data. To control the import process, you can create an import options object. The object has properties that you can adjust based on your import needs.

Create Import Options

To create an import options object for a sample data set, `airlinesmall.csv`, use the `detectImportOptions` function. The `detectImportOptions` function creates a `DelimitedTextImportOptions` object for this text file. For a full list of properties of the import options object, see the `detectImportOptions` reference page.

```
opts = detectImportOptions('airlinesmall.csv');
```

Customize Table-Level Import Options

The import options object has properties that you can adjust to control the import process. Some properties apply to the entire table while others apply to specific variables. Properties that affect the entire table include rules to manage error-causing or missing data. For example, remove rows with data that cause import errors by setting the `ImportErrorRule` to `'omitrow'`. Replace missing values by setting the `MissingRule` to `'fill'`. The `FillValue` property value determines what value replaces the missing values. For example, you can replace missing values with `NaN`.

```
opts.ImportErrorRule = 'omitrow';
opts.MissingRule = 'fill';
```

Customize Variable-Level Import Options

To get and set options for specific variables use the `getvaropts`, `setvartype`, and `setvaropts` functions. For example, view the current options for the variables named `FlightNum`, `Origin`, `Dest`, and `ArrDelay`, using the `getvaropts` function.

```
getvaropts(opts, {'FlightNum', 'Origin', 'Dest', 'ArrDelay'});
```

Change the data types for the variables using the `setvartype` function:

- Since the values in the variable `FlightNum` are identifiers for the flight and not numerical values, change its data type to `char`.
- Since the variables `Origin` and `Dest` designate a finite set of repeating text values, change their data type to `categorical`.

```
opts = setvartype(opts, {'FlightNum', 'Origin', 'Dest', 'ArrDelay'}, ...
                    {'char', 'categorical', 'categorical', 'single'});
```

Change other properties using the `setvaropts` function:

- For the `FlightNum` variable, remove any leading white spaces from the text by setting the `WhiteSpaceRule` property to `trimleading`.
- For the `ArrDelay` variable, replace fields containing `0` or `NA` with the value specified in `FillValue` property by setting the `TreatAsMissing` property.

```
opts = setvaropts(opts, 'FlightNum', 'WhitespaceRule', 'trimleading');
opts = setvaropts(opts, 'ArrDelay', 'TreatAsMissing', {'0', 'NA'});
```

Import Table

Specify the variables to get, import them using `readtable`, and display the first 8 rows of the table.

```
opts.SelectedVariableNames = {'FlightNum', 'Origin', 'Dest', 'ArrDelay'};
T = readtable('airlinesmall.csv', opts);
T(1:8, :)
```

```
ans=8x4 table
  FlightNum   Origin   Dest   ArrDelay
  _____  _____  _____  _____
 {'1503'}    LAX      SJC      8
 {'1550'}    SJC      BUR      8
 {'1589'}    SAN      SMF     21
 {'1655'}    BUR      SJC     13
 {'1702'}    SMF      LAX      4
 {'1729'}    LAX      SJC     59
 {'1763'}    SAN      SFO      3
 {'1800'}    SEA      LAX     11
```

See Also

`detectImportOptions` | `getvaropts` | `setvaropts` | `setvartype` | `readtable` | `SpreadsheetImportOptions` | `DelimitedTextImportOptions` | `readmatrix` | `readcell` | `readvars`

More About

- “Read Spreadsheet Data Using Import Tool” on page 3-4
- “Read Spreadsheet Data into Table” on page 3-9

Low-Level File I/O

- “Import Text Data Files with Low-Level I/O” on page 4-2
- “Import Binary Data with Low-Level I/O” on page 4-8
- “Export to Text Data Files with Low-Level I/O” on page 4-13
- “Export Binary Data with Low-Level I/O” on page 4-18

Import Text Data Files with Low-Level I/O

In this section...

“Overview” on page 4-2

“Reading Data in a Formatted Pattern” on page 4-2

“Reading Data Line-by-Line” on page 4-4

“Testing for End of File (EOF)” on page 4-5

“Opening Files with Different Character Encodings” on page 4-7

Overview

Low-level file I/O functions allow the most control over reading or writing data to a file. However, these functions require that you specify more detailed information about your file than the easier-to-use *high-level functions*, such as `importdata`. For more information on the high-level functions that read text files, see “Import Text Files” on page 2-2.

If the high-level functions cannot import your data, use one of the following:

- `fscanf`, which reads formatted data in a text or ASCII file; that is, a file you can view in a text editor. For more information, see “Reading Data in a Formatted Pattern” on page 4-2.
- `fgetl` and `fgets`, which read one line of a file at a time, where a newline character separates each line. For more information, see “Reading Data Line-by-Line” on page 4-4.
- `fread`, which reads a stream of data at the byte or bit level. For more information, see “Import Binary Data with Low-Level I/O” on page 4-8.

For additional information, see:

- “Testing for End of File (EOF)” on page 4-5
- “Opening Files with Different Character Encodings” on page 4-7

Note The low-level file I/O functions are based on functions in the ANSI® Standard C Library. However, MATLAB includes *vectorized* versions of the functions, to read and write data in an array with minimal control loops.

Reading Data in a Formatted Pattern

To import text files that `importdata` and `textscan` cannot read, consider using `fscanf`. The `fscanf` function requires that you describe the format of your file, but includes many options for this format description.

For example, create a text file `mymeas.dat` as shown. The data in `mymeas.dat` includes repeated sets of times, dates, and measurements. The header text includes the number of sets of measurements, `N`:

```
Measurement Data
N=3
```

```
12:00:00
```

```

01-Jan-1977
4.21 6.55 6.78 6.55
9.15 0.35 7.57 NaN
7.92 8.49 7.43 7.06
9.59 9.33 3.92 0.31
09:10:02
23-Aug-1990
2.76 6.94 4.38 1.86
0.46 3.17 NaN 4.89
0.97 9.50 7.65 4.45
8.23 0.34 7.95 6.46
15:03:40
15-Apr-2003
7.09 6.55 9.59 7.51
7.54 1.62 3.40 2.55
NaN 1.19 5.85 5.05
6.79 4.98 2.23 6.99

```

Opening the File

As with any of the low-level I/O functions, before reading, open the file with `fopen`, and obtain a file identifier. By default, `fopen` opens files for read access, with a permission of `'r'`.

When you finish processing the file, close it with `fclose(fid)`.

Describing the Data

Describe the data in the file with format specifiers, such as `'%s'` for text, `'%d'` for an integer, or `'%f'` for a floating-point number. (For a complete list of specifiers, see the `fscanf` reference page.)

To skip literal characters in the file, include them in the format description. To skip a data field, use an asterisk (`'*'`) in the specifier.

For example, consider the header lines of `my meas.dat`:

```

Measurement Data % skip the first 2 words, go to next line: %*s %*s\n
N=3              % ignore 'N=', read integer: N=%d\n
                 % go to next line: \n
12:00:00
01-Jan-1977
4.21 6.55 6.78 6.55
...

```

To read the headers and return the single value for `N`:

```
N = fscanf(fid, '%*s %*s\nN=%d\n\n', 1);
```

Specifying the Number of Values to Read

By default, `fscanf` reapplies your format description until it cannot match the description to the data, or it reaches the end of the file.

Optionally, specify the number of values to read, so that `fscanf` does not attempt to read the entire file. For example, in `my meas.dat`, each set of measurements includes a fixed number of rows and columns:

```
measrows = 4;
meascols = 4;
meas = fscanf(fid, '%f', [measrows, meascols]);
```

Creating Variables in the Workspace

There are several ways to store `mymeas.dat` in the MATLAB workspace. In this case, read the values into a structure. Each element of the structure has three fields: `mtime`, `mdate`, and `meas`.

Note `fscanf` fills arrays with numeric values in column order. To make the output array match the orientation of numeric data in a file, transpose the array.

```
filename = 'mymeas.dat';
measrows = 4;
meascols = 4;

% open the file
fid = fopen(filename);

% read the file headers, find N (one value)
N = fscanf(fid, '%*s %*s\nN=%d\n\n', 1);

% read each set of measurements
for n = 1:N
    mystruct(n).mtime = fscanf(fid, '%s', 1);
    mystruct(n).mdate = fscanf(fid, '%s', 1);

    % fscanf fills the array in column order,
    % so transpose the results
    mystruct(n).meas = ...
        fscanf(fid, '%f', [measrows, meascols]);
end

% close the file
fclose(fid);
```

Reading Data Line-by-Line

MATLAB provides two functions that read lines from files and store them as character vectors: `fgetl` and `fgets`. The `fgets` function copies the line along with the newline character to the output, but `fgetl` does not.

The following example uses `fgetl` to read an entire file one line at a time. The function `litcount` determines whether a given character sequence (`literal`) appears in each line. If it does, the function prints the entire line preceded by the number of times the literal appears on the line.

```
function y = litcount(filename, literal)
% Count the number of times a given literal appears in each line.

fid = fopen(filename);
y = 0;
tline = fgetl(fid);
while ischar(tline)
    matches = strfind(tline, literal);
    num = length(matches);
```

```

    if num > 0
        y = y + num;
        fprintf(1, '%d:%s\n', num, tline);
    end
    tline = fgetl(fid);
end
fclose(fid);

```

Create an input data file called `badpoem`:

```

Oranges and lemons,
Pineapples and tea.
Orangutans and monkeys,
Dragonflys or fleas.

```

To find out how many times 'an' appears in this file, call `litcount`:

```
litcount('badpoem', 'an')
```

This returns:

```

2: Oranges and lemons,
1: Pineapples and tea.
3: Orangutans and monkeys,
ans =
     6

```

Testing for End of File (EOF)

When you read a portion of your data at a time, you can use `feof` to check whether you have reached the end of the file. `feof` returns a value of 1 when the file pointer is at the end of the file. Otherwise, it returns 0.

Note Opening an empty file does *not* move the file position indicator to the end of the file. Read operations, and the `fseek` and `frewind` functions, move the file position indicator.

Testing for EOF with `feof`

When you use `textscan`, `fscanf`, or `fread` to read portions of data at a time, use `feof` to check whether you have reached the end of the file.

For example, suppose that the hypothetical file `mymeas.dat` has the following form, with no information about the number of measurement sets. Read the data into a structure with fields for `mtime`, `mdate`, and `meas`:

```

12:00:00
01-Jan-1977
4.21 6.55 6.78 6.55
9.15 0.35 7.57 NaN
7.92 8.49 7.43 7.06
9.59 9.33 3.92 0.31
09:10:02
23-Aug-1990
2.76 6.94 4.38 1.86
0.46 3.17 NaN 4.89

```

```
0.97  9.50  7.65  4.45
8.23  0.34  7.95  6.46
```

To read the file:

```
filename = 'mymeas.dat';
measrows = 4;
meascols = 4;

% open the file
fid = fopen(filename);

% make sure the file is not empty
finfo = dir(filename);
fsize = finfo.bytes;

if fsize > 0

    % read the file
    block = 1;
    while ~feof(fid)
        mystruct(block).mtime = fscanf(fid, '%s', 1);
        mystruct(block).mdate = fscanf(fid, '%s', 1);

        % fscanf fills the array in column order,
        % so transpose the results
        mystruct(block).meas = ...
            fscanf(fid, '%f', [measrows, meascols]);

        block = block + 1;
    end

end

% close the file
fclose(fid);
```

Testing for EOF with fgetl and fgets

If you use `fgetl` or `fgets` in a control loop, `feof` is not always the best way to test for end of file. As an alternative, consider checking whether the value that `fgetl` or `fgets` returns is a character vector.

For example, the function `litcount` described in “Reading Data Line-by-Line” on page 4-4 includes the following while loop and `fgetl` calls :

```
y = 0;
tline = fgetl(fid);
while ischar(tline)
    matches = strfind(tline, literal);
    num = length(matches);
    if num > 0
        y = y + num;
        fprintf(1, '%d:%s\n', num, tline);
    end
    tline = fgetl(fid);
end
```

This approach is more robust than testing `~feof(fid)` for two reasons:

- If `fgetl` or `fgets` find data, they return a character vector. Otherwise, they return a number (-1).
- After each read operation, `fgetl` and `fgets` check the next character in the file for the end-of-file marker. Therefore, these functions sometimes set the end-of-file indicator *before* they return a value of -1. For example, consider the following three-line text file. Each of the first two lines ends with a newline character, and the third line contains only the end-of-file marker:

```
123
456
```

Three sequential calls to `fgetl` yield the following results:

```
t1 = fgetl(fid);    % t1 = '123', feof(fid) = false
t2 = fgetl(fid);    % t2 = '456', feof(fid) = true
t3 = fgetl(fid);    % t3 = -1,   feof(fid) = true
```

This behavior does not conform to the ANSI specifications for the related C language functions.

Opening Files with Different Character Encodings

Encoding schemes support the characters required for particular alphabets, such as those for Japanese or European languages. Common encoding schemes include US-ASCII or UTF-8.

If you do not specify an encoding scheme when opening a file for reading, `fopen` uses auto character-set detection to determine the encoding. If you do not specify an encoding scheme when opening a file for writing, `fopen` defaults to using UTF-8 in order to provide interoperability between all platforms and locales without data loss or corruption.

To determine the default, open a file, and call `fopen` again with the syntax:

```
[filename, permission, machineformat, encoding] = fopen(fid);
```

If you specify an encoding scheme when you open a file, the following functions apply that scheme: `fscanf`, `fprintf`, `fgetl`, `fgets`, `fread`, and `fwrite`.

For a complete list of supported encoding schemes, and the syntax for specifying the encoding, see the `fopen` reference page.

Import Binary Data with Low-Level I/O

In this section...

“Low-Level Functions for Importing Data” on page 4-8
“Reading Binary Data in a File” on page 4-8
“Reading Portions of a File” on page 4-10
“Reading Files Created on Other Systems” on page 4-12

Low-Level Functions for Importing Data

Low-level file I/O functions allow the most direct control over reading or writing data to a file. However, these functions require that you specify more detailed information about your file than the easier-to-use *high-level functions*. For a complete list of high-level functions and the file formats they support, see “Supported File Formats for Import and Export” on page 1-2.

If the high-level functions cannot import your data, use one of the following:

- `fscanf`, which reads formatted data in a text or ASCII file; that is, a file you can view in a text editor. For more information, see “Reading Data in a Formatted Pattern” on page 4-2.
- `fgetl` and `fgets`, which read one line of a file at a time, where a newline character separates each line. For more information, see “Reading Data Line-by-Line” on page 4-4.
- `fread`, which reads a stream of data at the byte or bit level. For more information, see “Reading Binary Data in a File” on page 4-8.

Note The low-level file I/O functions are based on functions in the ANSI Standard C Library. However, MATLAB includes *vectorized* versions of the functions, to read and write data in an array with minimal control loops.

Reading Binary Data in a File

As with any of the low-level I/O functions, before importing, open the file with `fopen`, and obtain a file identifier. When you finish processing a file, close it with `fclose(fileID)`.

By default, `fread` reads a file 1 byte at a time, and interprets each byte as an 8-bit unsigned integer (`uint8`). `fread` creates a column vector, with one element for each byte in the file. The values in the column vector are of class `double`.

For example, consider the file `nine.bin`, created as follows:

```
fid = fopen('nine.bin','w');  
fwrite(fid, [1:9]);  
fclose(fid);
```

To read all data in the file into a 9-by-1 column vector of class `double`:

```
fid = fopen('nine.bin');  
col9 = fread(fid);  
fclose(fid);
```

Changing the Dimensions of the Array

By default, `fread` reads all values in the file into a column vector. However, you can specify the number of values to read, or describe a two-dimensional output matrix.

For example, to read `nine.bin`, described in the previous example:

```
fid = fopen('nine.bin');

% Read only the first six values
col6 = fread(fid, 6);

% Return to the beginning of the file
frewind(fid);

% Read first four values into a 2-by-2 matrix
frewind(fid);
two_dim4 = fread(fid, [2, 2]);

% Read into a matrix with 3 rows and
% unspecified number of columns
frewind(fid);
two_dim9 = fread(fid, [3, inf]);

% Close the file
fclose(fid);
```

Describing the Input Values

If the values in your file are not 8-bit unsigned integers, specify the size of the values.

For example, consider the file `fpoint.bin`, created with double-precision values as follows:

```
myvals = [pi, 42, 1/3];

fid = fopen('fpoint.bin','w');
fwrite(fid, myvals, 'double');
fclose(fid);
```

To read the file:

```
fid = fopen('fpoint.bin');

% read, and transpose so samevals = myvals
samevals = fread(fid, 'double');

fclose(fid);
```

For a complete list of precision descriptions, see the `fread` function reference page.

Saving Memory

By default, `fread` creates an array of class `double`. Storing double-precision values in an array requires more memory than storing characters, integers, or single-precision values.

To reduce the amount of memory required to store your data, specify the class of the array using one of the following methods:

- Match the class of the input values with an asterisk ('*'). For example, to read single-precision values into an array of class `single`, use the command:

```
mydata = fread(fid, '*single')
```

- Map the input values to a new class with the '=>' symbol. For example, to read `uint8` values into an `uint16` array, use the command:

```
mydata = fread(fid, 'uint8=>uint16')
```

For a complete list of precision descriptions, see the `fread` function reference page.

Reading Portions of a File

MATLAB low-level functions include several options for reading portions of binary data in a file:

- Read a specified number of values at a time, as described in “Changing the Dimensions of the Array” on page 4-9. Consider combining this method with “Testing for End of File” on page 4-10.
- Move to a specific location in a file to begin reading. For more information, see “Moving within a File” on page 4-10.
- Skip a certain number of bytes or bits after each element read. For an example, see “Write and Read Complex Numbers” on page 4-21.

Testing for End of File

When you open a file, MATLAB creates a pointer to indicate the current position within the file.

Note Opening an empty file does *not* move the file position indicator to the end of the file. Read operations, and the `fseek` and `frewind` functions, move the file position indicator.

Use the `feof` function to check whether you have reached the end of a file. `feof` returns a value of 1 when the file pointer is at the end of the file. Otherwise, it returns 0.

For example, read a large file in parts:

```
filename = 'largedata.dat';           % hypothetical file
segsz = 10000;

fid = fopen(filename);

while ~feof(fid)
    currData = fread(fid, segsz);
    if ~isempty(currData)
        disp('Current Data:');
        disp(currData);
    end
end

fclose(fid);
```

Moving within a File

To read or write selected portions of data, move the file position indicator to any location in the file. For example, call `fseek` with the syntax

```
fseek(fid,offset,origin);
```

where:

- *fid* is the file identifier obtained from `fopen`.
- *offset* is a positive or negative offset value, specified in bytes.
- *origin* specifies the location from which to calculate the position:

'bof'	Beginning of file
'cof'	Current position in file
'eof'	End of file

Alternatively, to move easily to the beginning of a file:

```
frewind(fid);
```

Use `ftell` to find the current position within a given file. `ftell` returns the number of bytes from the beginning of the file.

For example, create a file `five.bin`:

```
A = 1:5;
fid = fopen('five.bin','w');
fwrite(fid, A,'short');
fclose(fid);
```

Because the call to `fwrite` specifies the `short` format, each element of `A` uses two storage bytes in `five.bin`.

Reopen `five.bin` for reading:

```
fid = fopen('five.bin','r');
```

Move the file position indicator forward 6 bytes from the beginning of the file:

```
status = fseek(fid,6,'bof');
```

File Position	bof	1	2	3	4	5	6	7	8	9	10	eof
File Contents		0	1	0	2	0	3	0	4	0	5	
File Position Indicator								↑				

Read the next element:

```
four = fread(fid,1,'short');
```

The act of reading advances the file position indicator. To determine the current file position indicator, call `ftell`:

```
position = ftell(fid)
```

```
position =
      8
```

File Position	bof	1	2	3	4	5	6	7	8	9	10	eof
File Contents		0	1	0	2	0	3	0	4	0	5	
File Position Indicator									↑			

To move the file position indicator back 4 bytes, call `fseek` again:

```
status = fseek(fid,-4,'cof');
```

File Position	bof	1	2	3	4	5	6	7	8	9	10	eof
File Contents		0	1	0	2	0	3	0	4	0	5	
File Position Indicator						↑						

Read the next value:

```
three = fread(fid,1,'short');
```

Reading Files Created on Other Systems

Different operating systems store information differently at the byte or bit level:

- *Big-endian* systems store bytes starting with the largest address in memory (that is, they start with the big end).
- *Little-endian* systems store bytes starting with the smallest address (the little end).

Windows systems use little-endian byte ordering, and UNIX systems use big-endian byte ordering.

To read a file created on an opposite-endian system, specify the byte ordering used to create the file. You can specify the ordering in the call to open the file, or in the call to read the file.

For example, consider a file with double-precision values named `little.bin`, created on a little-endian system. To read this file on a big-endian system, use one (or both) of the following commands:

- Open the file with

```
fid = fopen('little.bin', 'r', 'l')
```
- Read the file with

```
mydata = fread(fid, 'double', 'l')
```

where `'l'` indicates little-endian ordering.

If you are not sure which byte ordering your system uses, call the `computer` function:

```
[cinfo, maxsize, ordering] = computer
```

The returned *ordering* is `'L'` for little-endian systems, or `'B'` for big-endian systems.

Export to Text Data Files with Low-Level I/O

In this section...

“Write to Text Files Using fprintf” on page 4-13

“Append to or Overwrite Existing Text Files” on page 4-14

“Open Files with Different Character Encodings” on page 4-17

Write to Text Files Using fprintf

This example shows how to create text files, including combinations of numeric and character data and nonrectangular files, using the low-level `fprintf` function.

`fprintf` is based on its namesake in the ANSI® Standard C Library. However, MATLAB® uses a vectorized version of `fprintf` that writes data from an array with minimal control loops.

Open the File

Create a sample matrix `y` with two rows.

```
x = 0:0.1:1;
y = [x; exp(x)];
```

Open a file for writing with `fopen` and obtain a file identifier, `fileID`. By default, `fopen` opens a file for read-only access, so you must specify the permission to write or append, such as `'w'` or `'a'`.

```
fileID = fopen('exptable.txt','w');
```

Write to the File

Write a title, followed by a blank line using the `fprintf` function. To move to a new line in the file, use `'\n'`.

```
fprintf(fileID, 'Exponential Function\n\n');
```

Note: Some Windows® text editors, including Microsoft® Notepad, require a newline character sequence of `'\r\n'` instead of `'\n'`. However, `'\n'` is sufficient for Microsoft Word or WordPad.

Write the values in `y` in column order so that two values appear in each row of the file. `fprintf` converts the numbers or characters in the array inputs to text according to your specifications. Specify `'%f'` to print floating-point numbers.

```
fprintf(fileID, '%f %f\n',y);
```

Other common conversion specifiers include `'%d'` for integers or `'%s'` for characters. `fprintf` reapplies the conversion information to cycle through all values of the input arrays in column order.

Close the file using `fclose` when you finish writing.

```
fclose(fileID);
```

View the contents of the file using the `type` function.

```
type exptable.txt
```

```
Exponential Function
```

```
0.000000 1.000000
0.100000 1.105171
0.200000 1.221403
0.300000 1.349859
0.400000 1.491825
0.500000 1.648721
0.600000 1.822119
0.700000 2.013753
0.800000 2.225541
0.900000 2.459603
1.000000 2.718282
```

Additional Formatting Options

Optionally, include additional information in the call to `fprintf` to describe field width, precision, or the order of the output values. For example, specify the field width and number of digits to the right of the decimal point in the exponential table.

```
fileID = fopen('exptable_new.txt', 'w');

fprintf(fileID, 'Exponential Function\n\n');
fprintf(fileID, '%6.2f %12.8f\n', y);

fclose(fileID);
```

View the contents of the file.

```
type exptable_new.txt
```

```
Exponential Function
```

```
0.00 1.000000000
0.10 1.10517092
0.20 1.22140276
0.30 1.34985881
0.40 1.49182470
0.50 1.64872127
0.60 1.82211880
0.70 2.01375271
0.80 2.22554093
0.90 2.45960311
1.00 2.71828183
```

Append to or Overwrite Existing Text Files

This example shows how to append values to an existing text file, rewrite the entire file, and overwrite only a portion of the file.

By default, `fopen` opens files with read access. To change the type of file access, use the permission specifier in the call to `fopen`. Possible permission specifiers include:

- 'r' for reading
- 'w' for writing, discarding any existing contents of the file

- 'a' for appending to the end of an existing file

To open a file for both reading and writing or appending, attach a plus sign to the permission, such as 'w+' or 'a+'. If you open a file for both reading and writing, you must call `fseek` or `frewind` between read and write operations.

Append to Existing Text File

Create a file named `changing.txt`.

```
fileID = fopen('changing.txt','w');
fmt = '%5d %5d %5d %5d\n';
fprintf(fileID,fmt, magic(4));
fclose(fileID);
```

The current contents of `changing.txt` are:

```
16 5 9 4
```

```
2 11 7 14
```

```
3 10 6 15
```

```
13 8 12 1
```

Open the file with permission to append.

```
fileID = fopen('changing.txt','a');
```

Write the values [55 55 55 55] at the end of file:

```
fprintf(fileID,fmt,[55 55 55 55]);
```

Close the file.

```
fclose(fileID);
```

View the contents of the file using the `type` function.

```
type changing.txt
```

```
16    5    9    4
 2   11    7   14
 3   10    6   15
13    8   12    1
55   55   55   55
```

Overwrite Entire Text File

A text file consists of a contiguous set of characters, including newline characters. To replace a line of the file with a different number of characters, you must rewrite the line that you want to change and all subsequent lines in the file.

Replace the first line of `changing.txt` with longer, descriptive text. Because the change applies to the first line, rewrite the entire file.

```
replaceLine = 1;
numLines = 5;
```

```
newText = 'This file originally contained a magic square';

fileID = fopen('changing.txt','r');
mydata = cell(1, numLines);
for k = 1:numLines
    mydata{k} = fgetl(fileID);
end
fclose(fileID);

mydata{replaceLine} = newText;

fileID = fopen('changing.txt','w');
fprintf(fileID, '%s\n',mydata{:});
fclose(fileID);
```

View the contents of the file.

```
type changing.txt
```

```
This file originally contained a magic square
  2   11    7   14
  3   10    6   15
 13    8   12    1
 55   55   55   55
```

Overwrite Portion of Text File

Replace the third line of `changing.txt` with `[33 33 33 33]`. If you want to replace a portion of a text file with exactly the same number of characters, you do not need to rewrite any other lines in the file.

```
replaceLine = 3;
myformat = '%5d %5d %5d %5d\n';
newData = [33 33 33 33];
```

Move the file position marker to the correct line.

```
fileID = fopen('changing.txt','r+');
for k=1:(replaceLine-1);
    fgetl(fileID);
end
```

Call `fseek` between read and write operations.

```
fseek(fileID,0,'cof');

fprintf(fileID, myformat, newData);
fclose(fileID);
```

View the contents of the file.

```
type changing.txt
```

```
This file originally contained a magic square
  2   11    7   14
 33   33   33   33
```

13 8 12 1
55 55 55 55

Open Files with Different Character Encodings

Encoding schemes support the characters required for particular alphabets, such as those for Japanese or European languages. Common encoding schemes include US-ASCII or UTF-8.

If you do not specify an encoding scheme when opening a file for reading, `fopen` uses auto character-set detection to determine the encoding. If you do not specify an encoding scheme when opening a file for writing, `fopen` defaults to using UTF-8 in order to provide interoperability between all platforms and locales without data loss or corruption.

To determine the default, open a file, and call `fopen` again with the syntax:

```
[filename, permission, machineformat, encoding] = fopen(fid);
```

If you specify an encoding scheme when you open a file, the following functions apply that scheme: `fscanf`, `fprintf`, `fgetl`, `fgets`, `fread`, and `fwrite`.

For a complete list of supported encoding schemes, and the syntax for specifying the encoding, see the `fopen` reference page.

See Also

`fprintf` | `fopen` | `fseek`

More About

- “Formatting Text”
- “Write Data to Text Files” on page 2-22

Export Binary Data with Low-Level I/O

In this section...

“Low-Level Functions for Exporting Data” on page 4-18

“Write Binary Data to a File” on page 4-18

“Overwrite or Append to an Existing Binary File” on page 4-19

“Create a File for Use on a Different System” on page 4-20

“Write and Read Complex Numbers” on page 4-21

Low-Level Functions for Exporting Data

Low-level file I/O functions allow the most direct control over reading or writing data to a file. However, these functions require that you specify more detailed information about your file than the easier-to-use *high-level functions*. For a complete list of high-level functions and the file formats they support, see “Supported File Formats for Import and Export” on page 1-2.

If the high-level functions cannot export your data, use one of the following:

- `fprintf`, which writes formatted data to a text or ASCII file; that is, a file you can view in a text editor or import into a spreadsheet. For more information, see “Export to Text Data Files with Low-Level I/O” on page 4-13.
- `fwrite`, which writes a stream of binary data to a file. For more information, see “Write Binary Data to a File” on page 4-18.

Note The low-level file I/O functions are based on functions in the ANSI Standard C Library. However, MATLAB includes *vectorized* versions of the functions, to read and write data in an array with minimal control loops.

Write Binary Data to a File

This example shows how to use the `fwrite` function to export a stream of binary data to a file.

Create a file named `nine.bin` with the integers from 1 to 9. As with any of the low-level I/O functions, before writing, open or create a file with `fopen` and obtain a file identifier.

```
fileID = fopen('nine.bin','w');  
fwrite(fileID, [1:9]);
```

By default, `fwrite` writes values from an array in column order as 8-bit unsigned integers (`uint8`).

When you finish processing a file, close it with `fclose`.

```
fclose(fileID);
```

Create a file with double-precision values. You must specify the precision of the values if the values in your matrix are not 8-bit unsigned integers.

```
mydata = [pi 42 1/3];
```

```
fileID = fopen('double.bin','w');
fwrite(fileID,mydata,'double');
fclose(fileID);
```

Overwrite or Append to an Existing Binary File

This example shows how to overwrite a portion of an existing binary file and append values to the file.

By default, `fopen` opens files with read access. To change the type of file access, use the permission specifier in the call to `fopen`. Possible permission specifiers include:

- 'r' for reading
- 'w' for writing, discarding any existing contents of the file
- 'a' for appending to the end of an existing file

To open a file for both reading and writing or appending, attach a plus sign to the permission, such as 'w+' or 'a+'. If you open a file for both reading and writing, you must call `fseek` or `frewind` between read and write operations.

Overwrite a Portion of an Existing File

Create a file named `magic4.bin`, specifying permission to write and read.

```
fileID = fopen('magic4.bin','w+');
fwrite(fileID,magic(4));
```

The original `magic(4)` matrix is:

```
16 2 3 13
5 11 10 8
9 7 6 12
4 14 15 1
```

The file contains 16 bytes, 1 for each value in the matrix.

Replace the values in the second column of the matrix with the vector, `[44 44 44 44]`. To do this, first seek to the fourth byte from the beginning of the file using `fseek`.

```
fseek(fileID,4,'bof');
```

Write the vector `[44 44 44 44]` using `fwrite`.

```
fwrite(fileID,[44 44 44 44]);
```

Read the results from the file into a 4-by-4 matrix.

```
frewind(fileID);
newdata = fread(fileID,[4,4])
```

```
newdata = 4×4
```

```
16  44   3  13
 5  44  10   8
 9  44   6  12
 4  44  15   1
```

Close the file.

```
fclose(fileID);
```

Append Binary Data to Existing File

Append the values [55 55 55 55] to magic4.bin. First, open the file with permission to append and read.

```
fileID = fopen('magic4.bin', 'a+');
```

Write values at end of file.

```
fwrite(fileID, [55 55 55 55]);
```

Read the results from the file into a 4-by-5 matrix.

```
frewind(fileID);
appended = fread(fileID, [4,5])
```

```
appended = 4x5
```

```
16  44   3  13  55
 5  44  10   8  55
 9  44   6  12  55
 4  44  15   1  55
```

Close the file.

```
fclose(fileID);
```

Create a File for Use on a Different System

Different operating systems store information differently at the byte or bit level:

- *Big-endian* systems store bytes starting with the largest address in memory (that is, they start with the big end).
- *Little-endian* systems store bytes starting with the smallest address (the little end).

Windows systems use little-endian byte ordering, and UNIX systems use big-endian byte ordering.

To create a file for use on an opposite-endian system, specify the byte ordering for the target system. You can specify the ordering in the call to open the file, or in the call to write the file.

For example, to create a file named `myfile.bin` on a big-endian system for use on a little-endian system, use one (or both) of the following commands:

- Open the file with

```
fid = fopen('myfile.bin', 'w', 'l')
```

- Write the file with

```
fwrite(fid, mydata, precision, 'l')
```

where 'l' indicates little-endian ordering.

If you are not sure which byte ordering your system uses, call the `computer` function:

```
[cinfo, maxsize, ordering] = computer
```

The returned *ordering* is 'L' for little-endian systems, or 'B' for big-endian systems.

Write and Read Complex Numbers

This example shows how to write and read complex numbers in binary files.

The available precision values for `fwrite` do not explicitly support complex numbers. To store complex numbers in a file, separate the real and imaginary components and write them separately to the file. There are two ways to do this:

- Write all real components followed by all imaginary components
- Interleave the components

Use the approach that allows you to read the data in your target application.

Separate Real and Imaginary Components

Create an array that contains complex values.

```
nrows = 5;
ncols = 5;
z = complex(rand(nrows, ncols), rand(nrows, ncols))
```

z = 5×5 complex

```
0.8147 + 0.7577i    0.0975 + 0.7060i    0.1576 + 0.8235i    0.1419 + 0.4387i    0.6557 + 0.4898i
0.9058 + 0.7431i    0.2785 + 0.0318i    0.9706 + 0.6948i    0.4218 + 0.3816i    0.0357 + 0.4456i
0.1270 + 0.3922i    0.5469 + 0.2769i    0.9572 + 0.3171i    0.9157 + 0.7655i    0.8491 + 0.6463i
0.9134 + 0.6555i    0.9575 + 0.0462i    0.4854 + 0.9502i    0.7922 + 0.7952i    0.9340 + 0.7094i
0.6324 + 0.1712i    0.9649 + 0.0971i    0.8003 + 0.0344i    0.9595 + 0.1869i    0.6787 + 0.7547i
```

Separate the complex values into real and imaginary components.

```
z_real = real(z);
z_imag = imag(z);
```

Write All Real Components Followed By Imaginary Components

Write all the real components, `z_real`, followed by all the imaginary components, `z_imag`, to a file named `complex_adj.bin`.

```
adjacent = [z_real z_imag];

fileID = fopen('complex_adj.bin', 'w');
fwrite(fileID, adjacent, 'double');
fclose(fileID);
```

Read the values from the file using `fread`.

```
fileID = fopen('complex_adj.bin');
same_real = fread(fileID, [nrows, ncols], 'double');
same_imag = fread(fileID, [nrows, ncols], 'double');
fclose(fileID);

same_z = complex(same_real, same_imag);
```

Interleave Real and Imaginary Components

An alternative approach is to interleave the real and imaginary components for each value. `fwrite` writes values in column order, so build an array that combines the real and imaginary parts by alternating rows.

First, preallocate the interleaved array.

```
interleaved = zeros(nrows*2, ncols);
```

Alternate real and imaginary data.

```
newrow = 1;
for row = 1:nrows
    interleaved(newrow,:) = z_real(row,:);
    interleaved(newrow + 1,:) = z_imag(row,:);
    newrow = newrow + 2;
end
```

Write the interleaved values to a file named `complex_int.bin`.

```
fileID = fopen('complex_int.bin','w');
fwrite(fileID, interleaved, 'double');
fclose(fileID);
```

Open the file for reading and read the real values from the file. The fourth input to `fread` tells the function to skip the specified number of bytes after reading each value.

```
fileID = fopen('complex_int.bin');
same_real = fread(fileID, [nrows, ncols], 'double', 8);
```

Return to the first imaginary value in the file. Then, read all the imaginary data.

```
fseek(fileID, 8, 'bof');
same_imag = fread(fileID, [nrows, ncols], 'double', 8);
fclose(fileID);

same_z = complex(same_real, same_imag);
```

See Also

`fopen` | `fwrite` | `fread` | `fseek`

More About

- “Moving within a File” on page 4-10

Internet of Things (IoT) Data

- “Aggregate Data in ThingSpeak Channel” on page 5-2
- “Regularize Irregularly Sampled Data” on page 5-3
- “Plot Data Read from ThingSpeak Channel” on page 5-4
- “Read ThingSpeak Data and Predict Battery Discharge Time with Linear Fit” on page 5-6

Aggregate Data in ThingSpeak Channel

This example shows how to aggregate data to a lower time resolution in a ThingSpeak™ channel to remove irregularity. Irregularity in a data can be caused due to several factors such as event driven sensing, malfunctioning of sensors, or network latencies.

Read Data

ThingSpeak channel 22641 contains tide and weather data measured once a minute at Ockway Bay, Cape Cod. Field 2 of the channel contains air temperature data. Read the air temperature data for the past 3 hours from channel 22641 using the `thingSpeakRead` function.

```
datetimeStop = dateshift(datetime('now'),'start','hour');
datetimeStart = dateshift(datetime('now'),'start','hour') - hours(3);

data = thingSpeakRead(22641,'DateRange',[datetimeStart,datetimeStop],...
    'Fields',2,'outputFormat','timetable');
```

Aggregate the Data

Data is measured once every minute. However, due to network latency associated with the measurement system, the actual timestamps can be greater than or less than a minute apart. Further, for the application of interest, the frequency of data measured every minute is high. Data at an hourly time resolution is sufficient. You can use the `retime` function to aggregate the data for each hour to a single value. You can use the maximum value for each hour to aggregate the data. Preview the first four values of the data with `head`.

```
dataHourly = retime(data,'hourly','max');
head(dataHourly,4)
```

ans =

3×1 timetable

Timestamps	AirTemperatureC
03-Jan-2019 14:00:00	7.5
03-Jan-2019 15:00:00	6.9
03-Jan-2019 16:00:00	6.4

Send Data to ThingSpeak

Change the `channelID` and the `writeAPIKey` to send data to your channel

```
channelID=17504;
writeAPIKey='23ZLG0BBU9TWHG2H';
thingSpeakWrite(channelID,data,'writeKey',writeAPIKey);
```

See Also

`thingSpeakRead` | `thingSpeakWrite` | `retime`

Regularize Irregularly Sampled Data

This example shows how to regularize irregularly sampled data to have a constant time period between measurements. You update timestamps of data read from a ThingSpeak™ channel to remove irregularity, then write the data to a channel. Timestamp variations in measured data introduced due to network latencies or hardware resets can affect data preprocessing and data analytics algorithms. Many algorithms require regularly sampled data to work correctly.

Read Data from the Weather Station Channel

ThingSpeak channel 12397 contains data from the MathWorks® weather station, located in Natick, Massachusetts. The data is collected once every minute. Field 4 of the channel contains air temperature data. To check for irregularly sampled data, read the air temperature data from channel 12397 using the `thingSpeakRead` function.

```
data = thingSpeakRead(12397,'NumMin',60,'Fields',4,'outputFormat','timetable');
```

Check for Irregularly Sampled Data

The data for the last 60 minutes read from channel 12397 is stored in as a timetable. Use `isregular` function to check if the channel data is regularly sampled. If data is irregularly sampled, generate a regularly spaced time vector for the time period of interest. Generate a new time vector using `linspace` with the `startTime`, `stopTime`, and the number of measurements.

```
regularFlag = isregular(data,'Time');  
  
if ~regularFlag  
    startTime = data.Timestamps(1);  
    stopTime = data.Timestamps(end);  
    newTimeVector = linspace(startTime,stopTime,height(data));  
    data.Timestamps = newTimeVector;  
end
```

Send Data to ThingSpeak

Send the processed data to a ThingSpeak channel using the `thingSpeakWrite` function.

```
% Change the channelID and the writeAPIKey to send data to your channel.  
channelID=17504;  
writeAPIKey='23ZLGOBBU9TWHG2H';  
thingSpeakWrite(channelID,data,'WriteKey',writeAPIKey);
```

See Also

[thingSpeakRead](#) | [thingSpeakWrite](#) | [linspace](#)

Plot Data Read from ThingSpeak Channel

This example shows how to read data from a public ThingSpeak™ channel and create a simple plot visualization from the results.

Read Data from ThingSpeak Channel

ThingSpeak channel 102698 contains air quality data from a parking garage in Natick, Massachusetts. Field 5 is a measure of dust concentration.

```
[dustData, Timestamps]=thingSpeakRead(102698, 'Fields', 5, 'NumPoints', 3000);
```

Plot the Dust Concentration over Time

Use plot to visualize the data. Use ylabel and title to add labels to your plot.

```
plot(Timestamps, dustData);  
ylabel('Dust Concentration (ppm)');  
title('MathWorks Air Quality Station, East Parking Garage');
```

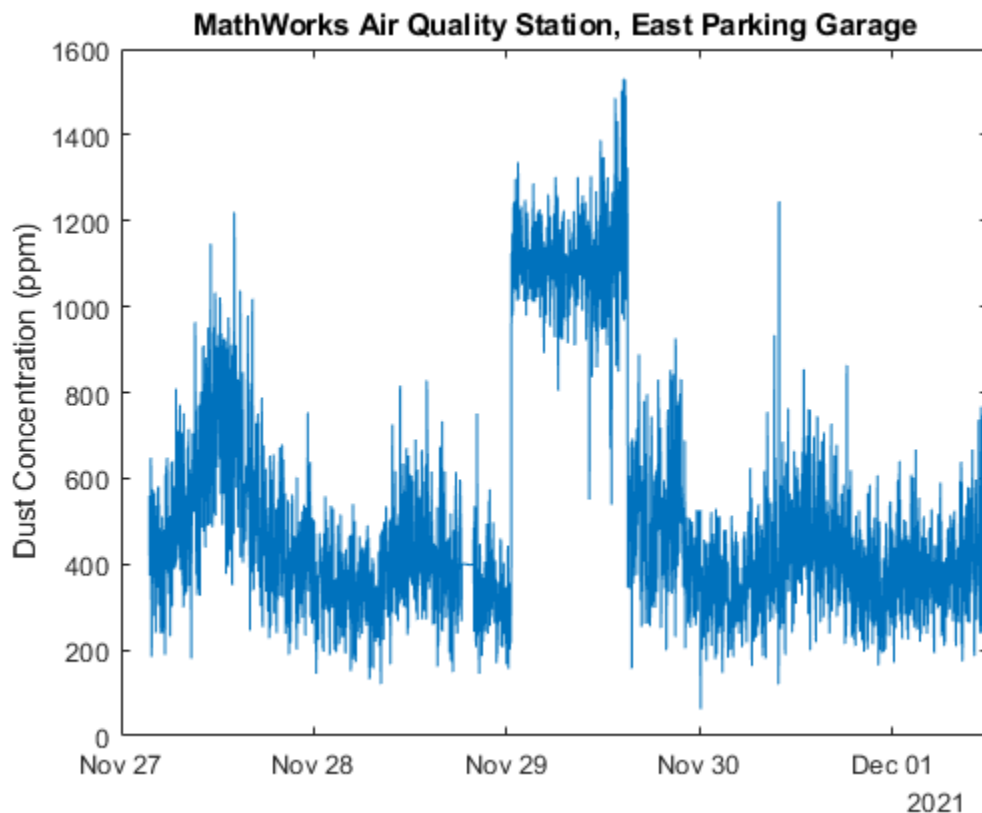

During business days, you can see spikes in the dust concentration at times when cars arrive or depart.

See Also

`thingSpeakRead | thingSpeakWrite | plot | ylabel | title`

Read ThingSpeak Data and Predict Battery Discharge Time with Linear Fit

This example shows how to read battery data from a ThingSpeak™ channel and analyze the data to determine the remaining battery life. Use a linear fit to predict the date that the battery will fail, and then write the remaining time in days to another ThingSpeak Channel. You read data for a 12 V battery connected to a microprocessor reporting its voltage to ThingSpeak every half hour. Then use regression to predict the day and time when the battery will fail.

Read Data from ThingSpeak Channel

Start by storing channel and date information in variables, and then use `thingSpeakRead` to read the data. Channel 592680 shows the scaled measurement of voltage from a 12 V battery. Use the `DateRange` name-value pair to use a specific selection of data.

```
batteryChannelID = 592680;  
startDate = datetime('Oct 20, 2018');  
endDate = datetime('Oct 23, 2018');  
batteryData = thingSpeakRead(batteryChannelID, 'DateRange', [startDate endDate], 'Outputformat', 'Time');
```

Convert the Data for Fitting and Plot

The channel stores raw data from the device. Convert the analog-to-digital converter (ADC) measurement to voltage using the experimentally determined conversion factor 14.6324. Then use `scatter` to generate a plot.

```
myVoltage = 14.6324 * batteryData.Voltage;  
scatter(batteryData.Timestamps, myVoltage, 'b');  
ylabel('Voltage (V)');  
hold on
```

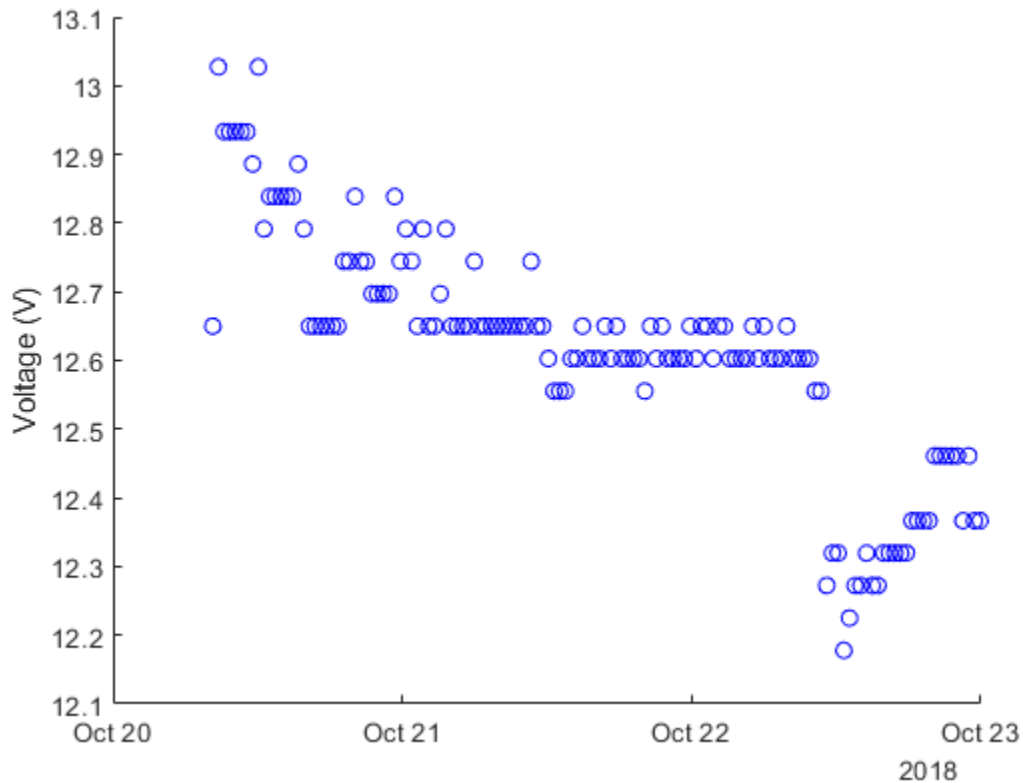

Fit the Data

The timetable datetime format is useful for reading and plotting. To fit the data, the datetime needs to be in numeric format. Use `datenum` to convert the timestamps into a number of days, and subtract the starting number to keep the values low. Use `polyfit` to perform linear regression on the data, and `polyval` to evaluate the fit at the existing time values. Add the fit line to the previous plot.

```
battTimes = datenum(batteryData.Timestamps);  
battTimes = battTimes - battTimes(1);  
myFit = polyfit(battTimes, myVoltage, 1);  
fitLine = polyval(myFit, battTimes);  
plot(batteryData.Timestamps, fitLine, 'r--');
```

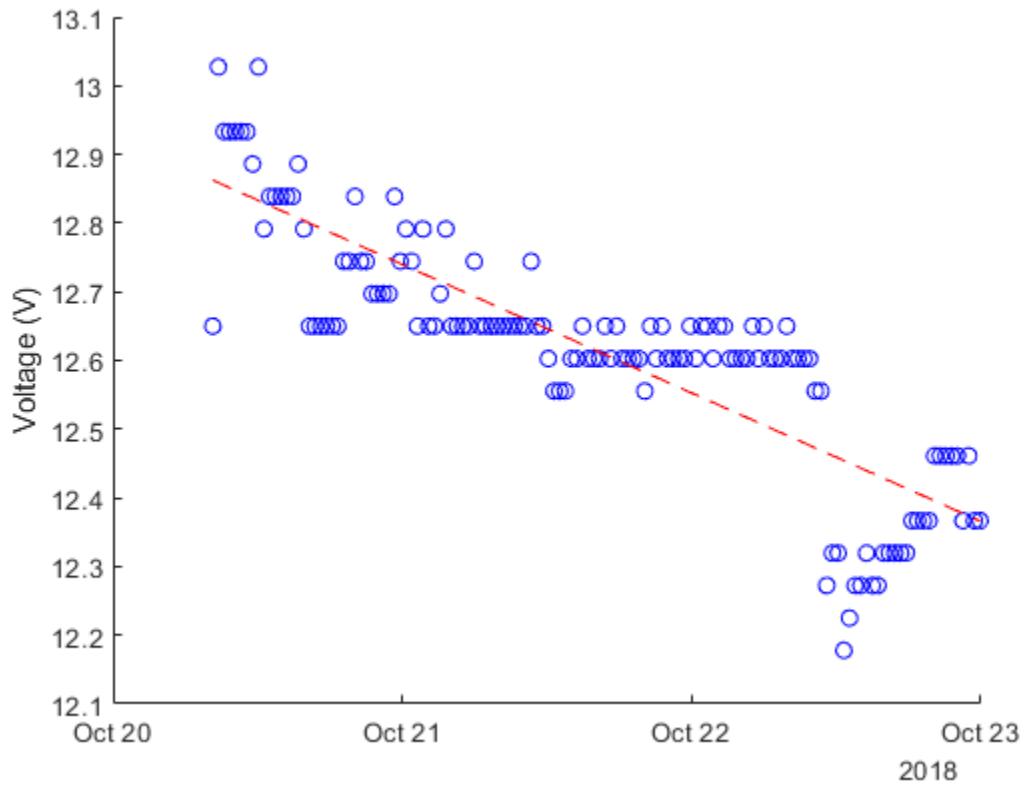

Predict Discharge Time

The battery should not be discharged below 10.4 V. Find the number of days until the fit line will intersect with this voltage.

```
endDays = (10.4-myFit(2))/myFit(1)
```

```
endDays = 13.1573
```

There are just over 13 days until the battery dies.

Write Prediction to ThingSpeak

The `thingSpeakWrite` function writes the result to a ThingSpeak channel. Return the output from `thingSpeakWrite` to ensure a successful write operation. Change the `writeChannelID` and `writeAPIKey` to write to your own channel.

```
writeChannelID = 17504;
writeAPIKey='23ZLGOBBU9TWHG2H';
result = thingSpeakWrite(writeChannelID,round(endDays,4),'WriteKey',writeAPIKey)
```

```
result = struct with fields:
    Field1: '13.1573'
    Field2: []
    Field3: []
    Field4: []
    Field5: []
    Field6: []
```

```
Field7: []  
Field8: []  
Latitude: []  
Longitude: []  
ChannelID: 17504  
Created: 03-Jun-2019 15:24:43  
LastEntryID: 50018  
Altitude: []
```

The result shows the successful write operation and reports the data that was written.

See Also

[thingSpeakRead](#) | [thingSpeakWrite](#) | [datetime](#) | [datenum](#) | [scatter](#) | [polyfit](#) | [polyval](#)

Images

- “Importing Images” on page 6-2
- “Exporting to Images” on page 6-5

Importing Images

To import data into the MATLAB workspace from a graphics file, use the `imread` function. Using this function, you can import data from files in many standard file formats, including the Tagged Image File Format (TIFF), Graphics Interchange Format (GIF), Joint Photographic Experts Group (JPEG), and Portable Network Graphics (PNG) formats. For a complete list of supported formats, see the `imread` reference page.

This example reads the image data stored in a file in JPEG format into the MATLAB workspace as the array `I`:

```
I = imread('ngc6543a.jpg');
```

`imread` represents the image in the workspace as a multidimensional array of class `uint8`. The dimensions of the array depend on the format of the data. For example, `imread` uses three dimensions to represent RGB color images:

```
whos I
  Name      Size                Bytes  Class
  I         650x600x3           1170000  uint8 array
```

```
Grand total is 1170000 elements using 1170000 bytes
```

For more control over reading TIFF files, use the `Tiff` object—see “Reading Image Data and Metadata from TIFF Files” on page 6-3 for more information.

Getting Information About Image Files

If you have a file in a standard graphics format, use the `imfinfo` function to get information about its contents. The `imfinfo` function returns a structure containing information about the file. The fields in the structure vary with the file format, but `imfinfo` always returns some basic information including the file name, last modification date, file size, and format.

This example returns information about a file in Joint Photographic Experts Group (JPEG) format:

```
info = imfinfo('ngc6543a.jpg')
```

```
info =
```

```
    Filename: 'matlabroot\toolbox\matlab\demos\ngc6543a.jpg'
  FileModDate: '01-Oct-1996 16:19:44'
    FileSize: 27387
      Format: 'jpg'
  FormatVersion: ''
      Width: 600
      Height: 650
    BitDepth: 24
    ColorType: 'truecolor'
  FormatSignature: ''
  NumberOfSamples: 3
    CodingMethod: 'Huffman'
  CodingProcess: 'Sequential'
      Comment: {'CREATOR: XV Version 3.00b  Rev: 6/15/94  Quality =...'}

```

Reading Image Data and Metadata from TIFF Files

While you can use `imread` to import image data and metadata from TIFF files, the function does have some limitations. For example, a TIFF file can contain multiple images and each images can have multiple subimages. While you can read all the images from a multi-image TIFF file with `imread`, you cannot access the subimages. Using the `Tiff` object, you can read image data, metadata, and subimages from a TIFF file. When you construct a `Tiff` object, it represents your connection with a TIFF file and provides access to many of the routines in the LibTIFF library.

A step-by-step example of using `Tiff` object methods and properties to read subimages from a TIFF file follows. To get the most out of the `Tiff` object, familiarize yourself with the TIFF specification and technical notes. See [LibTIFF - TIFF Library and Utilities](#).

Reading Subimages from a TIFF File

A TIFF file can contain one or more image file directories (IFD). Each IFD contains image data and the metadata (tags) associated with the image. Each IFD can contain one or more subIFDs, which also can contain image data and metadata. These subimages are typically reduced-resolution (thumbnail) versions of the image data in the IFD containing the subIFDs.

To read the subimages in an IFD, you must get the location of the subimage from the `SubIFD` tag. The `SubIFD` tag contains an array of byte offsets that point to the subimages. You then can pass the address of the subIFD to the `setSubDirectory` method to make the subIFD the current IFD. Most `Tiff` object methods operate on the current IFD.

- 1 Open a TIFF file that contains images and subimages using the `Tiff` object constructor. This example uses the TIFF file created in “Creating TIFF File Subdirectories” on page 6-8, which contains one IFD directory with two subIFDs. The `Tiff` constructor opens the TIFF file, and makes the first subIFD in the file the current IFD:

```
t = Tiff('my_subimage_file.tif','r');
```

- 2 Retrieve the locations of subIFDs associated with the current IFD. Use the `getTag` method to get the value of the `SubIFD` tag. This method returns an array of byte offsets that specify the location of subIFDs:

```
offsets = getTag(t,'SubIFD')
```

- 3 Navigate to the first subimage. First, set the `currentIFD` to the directory containing the first subimage:

```
dirNum = 1;
setDirectory(t,dirNum);
```

- 4 Then, navigate to the first subIFD using the `setSubDirectory` method. Specify the byte offset of the subIFD as an argument. This call makes the subIFD the current IFD:

```
setSubDirectory(t,offsets(1));
```

- 5 Read the image data from the current IFD (the first subIFD) the same way you read any other IFD in the file:

```
subimage_one = read(t);
```

- 6 View the first subimage:

```
imagesc(subimage_one)
```

- 7 Navigate to the second subimage. First, reset the `currentIFD` to the directory containing the second subimage:

```
setDirectory(t,dirNum);
```

- 8** Then, navigate to the second subIFD using the `setSubDirectory` method. Specify the byte offset of the second subIFD:

```
setSubDirectory(t,offsets(2));
```

- 9** Read the image data from the current IFD (the second subIFD) as you would with any other IFD in the file:

```
subimage_two = read(t);
```

- 10** View the second subimage:

```
imagesc(subimage_two)
```

- 11** Close the Tiff object:

```
close(t);
```

See Also

Tiff

External Websites

- “Exporting to Images” on page 6-5

Exporting to Images

To export data from the MATLAB workspace using one of the standard graphics file formats, use the `imwrite` function. Using this function, you can export data in formats such as the Tagged Image File Format (TIFF), Joint Photographic Experts Group (JPEG), and Portable Network Graphics (PNG). For a complete list of supported formats, see the `imwrite` reference page.

The following example writes a multidimensional array of `uint8` data `I` from the MATLAB workspace into a file in TIFF format. The class of the output image written to the file depends on the format specified. For most formats, if the input array is of class `uint8`, `imwrite` outputs the data as 8-bit values. See the `imwrite` reference page for details.

```
whos I
  Name      Size              Bytes  Class
  I         650x600x3          1170000 uint8 array
```

```
Grand total is 1170000 elements using 1170000 bytes
imwrite(I, 'my_graphics_file.tif','tif');
```

Note `imwrite` supports different syntaxes for several of the standard formats. For example, with TIFF file format, you can specify the type of compression MATLAB uses to store the image. See the `imwrite` reference page for details.

For more control writing data to a TIFF file, use the `Tiff` object—see “Exporting Image Data and Metadata to TIFF Files” on page 6-5 for more information.

Exporting Image Data and Metadata to TIFF Files

While you can use `imwrite` to export image data and metadata (tags) to Tagged Image File Format (TIFF) files, the function does have some limitations. For example, when you want to modify image data or metadata in the file, you must write the all the data to the file. You cannot write only the updated portion. Using the `Tiff` object, you can write portions of the image data and modify or add individual tags to a TIFF file. When you construct a `Tiff` object, it represents your connection with a TIFF file and provides access to many of the routines in the LibTIFF library.

The following sections provide step-by-step examples of using `Tiff` object methods and properties to perform some common tasks with TIFF files. To get the most out of the `Tiff` object, you must be familiar with the TIFF specification and technical notes. View this documentation at [LibTIFF - TIFF Library and Utilities](#).

Creating a New TIFF File

- 1 Create some image data. This example reads image data from a JPEG file included with MATLAB:

```
imgdata = imread('ngc6543a.jpg');
```

- 2 Create a new TIFF file by constructing a `Tiff` object, specifying the name of the new file as an argument. To create a file you must specify either write mode (`'w'`) or append mode (`'a'`):

```
t = Tiff('myfile.tif','w');
```

When you create a new TIFF file, the `Tiff` constructor creates a file containing an image file directory (IFD). A TIFF file uses this IFD to organize all the data and metadata associated with a

particular image. A TIFF file can contain multiple IFDs. The `Tiff` object makes the IFD it creates the current IFD. `Tiff` object methods operate on the current IFD. You can navigate among IFDs in a TIFF file and specify which IFD is the current IFD using `Tiff` object methods.

- 3 Set required TIFF tags using the `setTag` method of the `Tiff` object. These required tags specify information about the image, such as its length and width. To break the image data into strips, specify a value for the `RowsPerStrip` tag. To break the image data into tiles, specify values for the `TileWidth` and `TileLength` tags. The example creates a structure that contains tag names and values and passes that to `setTag`. You also can set each tag individually.

```
tagstruct.ImageLength = size(imgdata,1);
tagstruct.ImageWidth = size(imgdata,2);
tagstruct.Photometric = Tiff.Photometric.RGB;
tagstruct.BitsPerSample = 8;
tagstruct.SamplesPerPixel = 3;
tagstruct.RowsPerStrip = 16;
tagstruct.PlanarConfiguration = Tiff.PlanarConfiguration.Chunky;
tagstruct.Software = 'MATLAB';
tagstruct % display tagstruct
setTag(t,tagstruct)
```

For information about supported TIFF tags and how to set their values, see “Setting Tag Values” on page 6-9. For example, the `Tiff` object supports properties that you can use to set the values of certain properties. This example uses the `Tiff` object `PlanarConfiguration` property to specify the correct value for the chunky configuration:
`Tiff.PlanarConfiguration.Chunky`.

- 4 Write the image data and metadata to the current directory using the `write` method of the `Tiff` object.

```
write(t,imgdata);
```

If you wanted to put multiple images into your file, call the `writeDirectory` method right after performing this write operation. The `writeDirectory` method sets up a new image file directory in the file and makes this new directory the current directory.

- 5 Close your connection to the file by closing the `Tiff` object:

```
close(t);
```

- 6 Test that you created a valid TIFF file by using the `imread` function to read the file, and then display the image:

```
imagesc(imread('myfile.tif'));
```

Writing a Strip or Tile of Image Data

Note You can only modify a strip or a tile of image data if the data is not compressed.

- 1 Open an existing TIFF file for modification by creating a `Tiff` object. This example uses the file created in “Creating a New TIFF File” on page 6-5. The `Tiff` constructor returns a handle to a `Tiff` object.

```
t = Tiff('myfile.tif','r+');
```

- 2 Generate some data to write to a strip in the image. This example creates a three-dimensional array of zeros that is the size of a strip. The code uses the number of rows in a strip, the width of the image, and the number of samples per pixel as dimensions. The array is an array of `uint8` values.

```
width = getTag(t, 'ImageWidth');
height = getTag(t, 'RowsPerStrip');
numSamples = getTag(t, 'SamplesPerPixel');
stripData = zeros(height,width,numSamples,'uint8');
```

If the image data had a tiled layout, you would use the `TileWidth` and `TileLength` tags to specify the dimensions.

- 3 Write the data to a strip in the file using the `writeEncodedStrip` method. Specify the index number that identifies the strip you want to modify. The example picks strip 18 because it is easier to see the change in the image.

```
writeEncodedStrip(t,18,stripData);
```

If the image had a tiled layout, you would use the `writeEncodedTile` method to modify the tile.

- 4 Close your connection to the file by closing the `Tiff` object.

```
close(t);
```

- 5 Test that you modified a strip of the image in the TIFF file by using the `imread` function to read the file, and then display the image.

```
modified_imgdata = imread('myfile.tif');
imagesc(modified_imgdata)
```

Note the black strip across the middle of the image.

Modifying TIFF File Metadata (Tags)

- 1 Open an existing TIFF file for modification using the `Tiff` object. This example uses the file created in “Creating a New TIFF File” on page 6-5. The `Tiff` constructor returns a handle to a `Tiff` object.

```
t = Tiff('myfile.tif','r+');
```

- 2 Verify that the file does not contain the `Artist` tag, using the `getTag` method. This code should issue an error message saying that it was unable to retrieve the tag.

```
artist_value = getTag(t,'Artist');
```

- 3 Add the `Artist` tag using the `setTag` method.

```
setTag(t,'Artist','Pablo Picasso');
```

- 4 Write the new tag data to the TIFF file using the `rewriteDirectory` method. Use the `rewriteDirectory` method when modifying existing metadata in a file or adding new metadata to a file.

```
rewriteDirectory(t);
```

- 5 Close your connection to the file by closing the `Tiff` object.

```
close(t);
```

- 6 Test your work by reopening the TIFF file and getting the value of the `Artist` tag, using the `getTag` method.

```
t = Tiff('myfile.tif','r');
```

```
getTag(t,'Artist')
```

```
ans =
```

```
Pablo Picasso
```

```
close(t);
```

Creating TIFF File Subdirectories

- 1 Create some image data. This example reads image data from a JPEG file included with MATLAB. The example then creates two reduced-resolution (thumbnail) versions of the image data.

```
imgdata = imread('ngc6543a.jpg');
%
% Reduce number of pixels by a half.
img_half = imgdata(1:2:end,1:2:end,:);
%
```

- 2 Create a new TIFF file by constructing a `Tiff` object and specifying the name of the new file as an argument. To create a file you must specify either write mode ('w') or append mode ('a'). The `Tiff` constructor returns a handle to a `Tiff` object.

```
t = Tiff('my_subimage_file.tif','w');
```

- 3 Set required TIFF tags using the `setTag` method of the `Tiff` object. These required tags specify information about the image, such as its length and width. To break the image data into strips, specify a value for the `RowsPerStrip` tag. To break the image data into tiles, use the `TileWidth` and `TileLength` tags. The example creates a structure that contains tag names and values and passes that to `setTag`. You can also set each tag individually.

To create subdirectories, you must set the `SubIFD` tag, specifying the number of subdirectories you want to create. Note that the number you specify isn't the value of the `SubIFD` tag. The number tells the `Tiff` software to create a `SubIFD` that points to two subdirectories. The actual value of the `SubIFD` tag will be the byte offsets of the two subdirectories.

```
tagstruct.ImageLength = size(imgdata,1);
tagstruct.ImageWidth = size(imgdata,2);
tagstruct.Photometric = Tiff.Photometric.RGB;
tagstruct.BitsPerSample = 8;
tagstruct.SamplesPerPixel = 3;
tagstruct.RowsPerStrip = 16;
tagstruct.PlanarConfiguration = Tiff.PlanarConfiguration.Chunky;
tagstruct.Software = 'MATLAB';
tagstruct.SubIFD = 2 ; % required to create subdirectories
tagstruct % display tagstruct
setTag(t,tagstruct)
```

For information about supported TIFF tags and how to set their values, see “Setting Tag Values” on page 6-9. For example, the `Tiff` object supports properties that you can use to set the values of certain properties. This example uses the `Tiff` object `PlanarConfiguration` property to specify the correct value for the chunky configuration: `Tiff.PlanarConfiguration.Chunky`.

- 4 Write the image data and metadata to the current directory using the `write` method of the `Tiff` object.

```
write(t,imgdata);
```

- 5 Set up the first subdirectory by calling the `writeDirectory` method. The `writeDirectory` method sets up the subdirectory and make the new directory the current directory. Because you specified that you wanted to create two subdirectories, `writeDirectory` sets up a subdirectory.

```
writeDirectory(t);
```

- 6** Set required tags, just as you did for the regular directory. According to the LibTIFF API, a subdirectory cannot contain a SubIFD tag.

```
tagstruct2.ImageLength = size(img_half,1);
tagstruct2.ImageWidth = size(img_half,2);
tagstruct2.Photometric = Tiff.Photometric.RGB;
tagstruct2.BitsPerSample = 8;
tagstruct2.SamplesPerPixel = 3;
tagstruct2.RowsPerStrip = 16;
tagstruct2.PlanarConfiguration = Tiff.PlanarConfiguration.Chunky;
tagstruct2.Software = 'MATLAB';
tagstruct2 % display tagstruct2
setTag(t,tagstruct2)
```

- 7** Write the image data and metadata to the subdirectory using the `write` method of the `Tiff` object.

```
write(t,img_half);
```

- 8** Set up the second subdirectory by calling the `writeDirectory` method. The `writeDirectory` method sets up the subdirectory and makes it the current directory.

```
writeDirectory(t);
```

- 9** Set required tags, just as you would for any directory. According to the LibTIFF API, a subdirectory cannot contain a SubIFD tag.

```
tagstruct3.ImageLength = size(img_third,1);
tagstruct3.ImageWidth = size(img_third,2);
tagstruct3.Photometric = Tiff.Photometric.RGB;
tagstruct3.BitsPerSample = 8;
tagstruct3.SamplesPerPixel = 3;
tagstruct3.RowsPerStrip = 16;
tagstruct3.PlanarConfiguration = Tiff.PlanarConfiguration.Chunky;
tagstruct3.Software = 'MATLAB';
tagstruct3 % display tagstruct3
setTag(t,tagstruct3)
```

- 10** Write the image data and metadata to the subdirectory using the `write` method of the `Tiff` object:

```
write(t,img_third);
```

- 11** Close your connection to the file by closing the `Tiff` object:

```
close(t);
```

Setting Tag Values

The following table lists all the TIFF tags that the `Tiff` object supports and includes information about their MATLAB class and size. For certain tags, the table also indicates the set of values that the `Tiff` object supports, which is a subset of all the possible values defined by the TIFF specification. You can use the `Tiff` properties structure to specify the supported values for these tags. For example, use `Tiff.Compression.JPEG` to specify JPEG compression. See the `Tiff` reference page for a full list of properties.

Table 1: Supported TIFF Tags

TIFF Tag	Class	Size	Supported Values	Notes
Artist	char	1xN		
BitsPerSample	double	1x1	1,8,16,32,64	See Table 2 on page 6-14
ColorMap	double	256x3	Values should be normalized between 0-1. Stored internally as uint16 values.	Photometric must be Palette
Compression	double	1x1	None: 1 CCITTRLE: 2 CCITTFax3: 3 CCITTFax4: 4 LZW: 5 JPEG: 7 CCITTRLEW: 32771 PackBits: 32773 Deflate: 32946 AdobeDeflate: 8	See Table 3 on page 6-15.
Copyright	char	1xN		
DateTime	char	1x19	Return value is padded to 19 chars if required.	
DocumentName	char	1xN		
DotRange	double	1x2		Photometric must be Separated
ExtraSamples	double	1xN	Unspecified: 0 AssociatedAlpha: 1 UnassociatedAlpha: 2	See Table 4 on page 6-15.
FillOrder	double	1x1		
GeoAsciiParamsTag	char	1xN		
GeoDoubleParamsTag	double	1xN		
GeoKeyDirectoryTag	double	Nx4		
Group3Options	double	1x1		Compression must be CCITTFax3
Group4Options	double	1x1		Compression must be CCITTFax4
HalfToneHints	double	1x2		
HostComputer	char	1xn		
ICCProfile	uint8	1xn		
ImageDescription	char	1xn		
ImageLength	double	1x1		

TIFF Tag	Class	Size	Supported Values	Notes
ImageWidth	double	1x1		
InkNames	char cell array	1x NumInk s		Photometric must be Separated
InkSet	double	1x1	CMYK: 1 MultiInk: 2	Photometric must be Separated
JPEGQuality	double	1x1	A value between 1 and 100	
Make	char	1xn		
MaxSampleValue	double	1x1	0-65,535	
MinSampleValue	double	1x1	0-65,535	
Model	char	1xN		
ModelPixelScaleTag	double	1x3		
ModelTiepointTag	double	Nx6		
ModelTransformationMatrixTag	double	1x16		
NumberOfInks	double	1x1		Must be equal to SamplesPerPixel
Orientation	double	1x1	TopLeft: 1 TopRight: 2 BottomRight: 3 BottomLeft: 4 LeftTop: 5 RightTop: 6 RightBottom: 7 LeftBottom: 8	
PageName	char	1xN		
PageNumber	double	1x2		
Photometric	double	1x1	MinIsWhite: 0 MinIsBlack: 1 RGB: 2 Palette: 3 Mask: 4 Separated: 5 YCbCr: 6 CIE Lab: 8 ICCLab: 9 ITULab: 10	See Table 2 on page 6-14.
Photoshop	uint8	1xN		
PlanarConfiguration	double	1x1	Chunky: 1 Separate: 2	
PrimaryChromaticities	double	1x6		
ReferenceBlackWhite	double	1x6		

TIFF Tag	Class	Size	Supported Values	Notes
ResolutionUnit	double	1x1		
RICHTIFFIPTC	uint8	1xN		
RowsPerStrip	double	1x1		
RPCCoefficientTag	double	1x92	92-element row vector	See Table 6 on page 6-16
SampleFormat	double	1x1	Uint: 1 Int: 2 IEEEFP: 3	See Table 2 on page 6-13
SamplesPerPixel	double	1x1		
SMaxSampleValue	double	1x1	Range of MATLAB data type specified for Image data	
SMinSampleValue	double	1x1	Range of MATLAB data type specified for Image data	
Software	char	1xN		
StripByteCounts	double	1xN		Read-only
StripOffsets	double	1xN		Read-only
SubFileType	double	1x1	Default: 0 ReducedImage: 1 Page: 2 Mask: 4	
SubIFD	double	1x1		
TargetPrinter	char	1xN		
Thresholding	double	1x1	BiLevel: 1 HalfTone: 2 ErrorDiffuse: 3	Photometric can be either: MinIsWhite MinIsBlack
TileByteCounts	double	1xN		Read-only
TileLength	double	1x1	Must be a multiple of 16	
TileOffsets	double	1xN		Read-only
TileWidth	double	1x1	Must be a multiple of 16	
TransferFunction	double	See note ¹	Each value should be within 0-2 ¹⁶ -1	SamplePerPixel can be either 1 or 3
WhitePoint	double	1x2		Photometric can be: RGB Palette YCbCr CIELab ICCLab ITULab

TIFF Tag	Class	Size	Supported Values	Notes
XMP	char	1xn		N>5
XPosition	double	1x1		
XResolution	double	1x1		
YCbCrCoefficients	double	1x3		Photometric must be YCbCr
YCbCrPositioning	double	1x1	Centered: 1 Cosited: 2	Photometric must be YCbCr
YCbCrSubSampling	double	1x2		Photometric must be YCbCr
YPosition	double	1x1		
YResolution	double	1x1		
ZipQuality	double	1x1	Value between 1 and 9	

¹Size is $1 \times 2^{\text{BitsPerSample}}$ or $3 \times 2^{\text{BitsPerSample}}$.

Table 2: Valid SampleFormat Values for BitsPerSample Settings

BitsPerSample	SampleFormat	MATLAB Data Type
1	Uint	logical
8	Uint, Int	uint8, int8
16	Uint, Int	uint16, int16
32	Uint, Int, IEEEFP	uint32, int32, single
64	IEEEFP	double

Table 3: Valid SampleFormat Values for BitsPerSample and Photometric Combinations

Photometric Values	BitsPerSample Values				
	1	8	16	32	64
MinIsWhite	UInt	UInt/Int	UInt Int	UInt Int IEEEFP	IEEEFP
MinIsBlack	UInt	UInt/Int	UInt Int	UInt Int IEEEFP	IEEEFP
RGB		UInt	UInt	UInt IEEEFP	IEEEFP
Palette		UInt	UInt		
Mask	UInt				
Separated		UInt	UInt	UInt IEEEFP	IEEEFP
YCbCr		UInt	UInt	UInt IEEEFP	IEEEFP
CIELab		UInt	UInt		
ICCLab		UInt	UInt		
ITULab		UInt	UInt		

Table 4: Valid SampleFormat Values for BitsPerSample and Compression Combinations

Compression Values	BitsPerSample Values				
	1	8	16	32	64
None	UInt	UInt Int	UInt Int	UInt Int IEEEFP	IEEEFP
CCITTRLE	UInt				
CCITTFax3	UInt				
CCITTFax4	UInt				
LZW	UInt	UInt Int	UInt Int	UInt Int IEEEFP	IEEEFP
JPEG		UInt Int			
CCITTRLEW	UInt				
PackBits	UInt	UInt Int	UInt Int	UInt Int IEEEFP	IEEEFP
Deflate	UInt	UInt Int	UInt Int	UInt Int IEEEFP	IEEEFP
AdobeDeflate	UInt	UInt Int	UInt Int	UInt Int IEEEFP	IEEEFP

Table 5: Valid SamplesPerPixel Values for Photometric Settings

Photometric Values	SamplesPerPixel ¹
MinIsWhite	1+
MinIsBlack	1+
RGB	3+
Palette	1
Mask	1
Separated	1+
YCbCr	3
CIELab	3+
ICCLab	3+
ITULab	3+

Table 6: List of RPCCoefficientTag Value Descriptions

Index Value in 92-Element Vector	Value Descriptions ¹	Units
1	Root mean square bias error	meters per horizontal axis
2	Root mean square random error	meters per horizontal axis
3	Line offset	pixels
4	Sample offset	pixels
5	Geodetic latitude offset	degrees
6	Geodetic longitude offset	degrees
7	Geodetic height offset	meters
8	Line scale factor	pixels
9	Sample scale factor	pixels
10	Geodetic latitude scale	degrees
11	Geodetic longitude scale	degrees
12	Geodetic height scale factor	meters
13 through 32	Numerator coefficients of $r(n)$, a rational polynomial equation ²	
33 through 52	Denominator coefficients of the rational polynomial equation $r(n)$	
53 through 72	Numerator coefficients of $c(n)$, a rational polynomial equation ²	
73 through 92	Denominator coefficients of the rational polynomial equation $c(n)$	

¹To specify the values in this vector using the RPCCoefficientTag object, see RPCCoefficientTag (Mapping Toolbox) in the Mapping Toolbox™.

²Equations $r(n)$ and $c(n)$ represent the normalized row and column values of a generic rigorous projection model.

See Also

Tiff

External Websites

- “Importing Images” on page 6-2

Scientific Data

- “Import CDF Files Using Low-Level Functions” on page 7-2
- “Represent CDF Time Values” on page 7-4
- “Import CDF Files Using High-Level Functions” on page 7-5
- “Export to CDF Files” on page 7-8
- “Map NetCDF API Syntax to MATLAB Syntax” on page 7-11
- “Import NetCDF Files and OPeNDAP Data” on page 7-13
- “Resolve Errors Reading OPeNDAP Data” on page 7-20
- “Export to NetCDF Files” on page 7-21
- “Importing Flexible Image Transport System (FITS) Files” on page 7-27
- “Import HDF5 Files” on page 7-28
- “Export to HDF5 Files” on page 7-34
- “Work with Non-ASCII Characters in HDF5 Files” on page 7-41
- “Import HDF4 Files Programmatically” on page 7-44
- “Read and Write Data Concurrently Using Single-Writer/Multiple-Reader (SWMR)” on page 7-47
- “Work with HDF5 Virtual Datasets (VDS)” on page 7-52
- “Read and Write HDF5 Datasets Using Dynamically Loaded Filters” on page 7-59
- “Map HDF4 to MATLAB Syntax” on page 7-64
- “Import HDF4 Files Using Low-Level Functions” on page 7-65
- “About HDF4 and HDF-EOS” on page 7-68
- “Export to HDF4 Files” on page 7-69

Import CDF Files Using Low-Level Functions

This example shows how to use low-level functions to read data from a CDF file. The MATLAB® low-level CDF functions correspond to routines in the CDF C API library. To use the MATLAB CDF low-level functions effectively, you must be familiar with the CDF C interface.

Open CDF File

Open the sample CDF File, `example.cdf`.

```
cdfid = cdflib.open('example.cdf');
```

Get Information About File Contents

Use `cdflib.inquire` to get information about the number of variables in the file, the number of global attributes, and the number of attributes with variable scope.

```
info = cdflib.inquire(cdfid)

info = struct with fields:
    encoding: 'IBMPC_ENCODING'
    majority: 'ROW_MAJOR'
    maxRec: 23
    numVars: 6
    numvAttrs: 1
    numgAttrs: 3
```

Get Information About Variables

Use `cdflib.inquireVar` to get information about the individual variables in the file. Variable ID numbers start at zero.

```
info = cdflib.inquireVar(cdfid,0)

info = struct with fields:
    name: 'Time'
    datatype: 'cdf_epoch'
    numElements: 1
    dims: []
    recVariance: 1
    dimVariance: []

info = cdflib.inquireVar(cdfid,1)

info = struct with fields:
    name: 'Longitude'
    datatype: 'cdf_int1'
    numElements: 1
    dims: [2 2]
    recVariance: 0
    dimVariance: [1 0]
```

Read Variable Data into Workspace

Read the data in a variable into the MATLAB workspace. The first variable contains CDF Epoch time values. The low-level interface returns these as double values.

```
data_time = cdflib.getVarRecordData(cdfid,0,0)
```

```
data_time = 6.3146e+13
```

Convert the time value to a date vector.

```
timeVec = cdflib.epochBreakdown(data_time)
```

```
timeVec = 7×1
```

```
    2001
         1
         1
         0
         0
         0
         0
```

Read Global Attribute from File

Determine which attributes in the CDF file are global.

```
info = cdflib.inquireAttr(cdfid,0)
```

```
info = struct with fields:
    name: 'SampleAttribute'
    scope: 'GLOBAL_SCOPE'
    maxgEntry: 4
    maxEntry: -1
```

Read the value of the attribute. You must use the `cdflib.getAttrgEntry` function for global attributes.

```
value = cdflib.getAttrgEntry(cdfid,0,0)
```

```
value =
'This is a sample entry.'
```

Close CDF File

Use `cdflib.close` to close the CDF file.

```
cdflib.close(cdfid);
```

See Also

`cdflib` | `cdfread`

External Websites

- [CDF website](#)

Represent CDF Time Values

This example shows how to extract date information from a CDF epoch object. CDF represents time differently than MATLAB®. CDF represents date and time as the number of milliseconds since 1-Jan-0000. This is called an epoch in CDF terminology. To represent CDF dates, MATLAB uses an object called a CDF epoch object. MATLAB also can represent a date and time as a datetime value or as a serial date number, which is the number of days since 0-Jan-0000. To access the time information in a CDF object, convert to one of these other representations.

Read the sample CDF file, `example.cdf`.

```
data = cdfread('example.cdf');  
whos
```

Name	Size	Bytes	Class	Attributes
data	24x6	23904	cell	

`cdfread` returns a cell array.

Extract the date information from the first CDF epoch object returned in the cell array, `data`, using the `todatetime` function.

```
m_datenum = todatetime(data{1})
```

```
m_datenum = 730852
```

Convert the MATLAB serial date number to a datetime value.

```
m_datetime = datetime(m_datenum, 'ConvertFrom', 'datenum')
```

```
m_datetime = datetime  
01-Jan-2001
```

See Also

[todatetime](#) | [datetime](#) | [cdfread](#)

Import CDF Files Using High-Level Functions

This example shows how to use high-level MATLAB® functions to import the sample CDF file, `example.cdf`. High-level functions provide a simpler interface to accessing CDF files.

Get Information About Contents of CDF File

Get information about the contents of a CDF file using the `cdfinfo` function. Because `cdfinfo` creates temporary files, ensure that your current folder is writable before using the function.

```
info = cdfinfo('example.cdf')

info = struct with fields:
    Filename: 'example.cdf'
    FileModDate: '10-May-2010 21:35:01'
    FileSize: 1310
    Format: 'CDF'
    FormatVersion: '2.7.0'
    FileSettings: [1x1 struct]
    Subfiles: {}
    Variables: {6x6 cell}
    GlobalAttributes: [1x1 struct]
    VariableAttributes: [1x1 struct]
```

`cdfinfo` returns a structure containing general information about the file and detailed information about the variables and attributes in the file. In this example, the `Variables` field indicates the number of variables in the file.

View the contents of the `Variables` field.

```
vars = info.Variables

vars=6x6 cell array
  Columns 1 through 5

    {'Time'          }    {[ 1 1]}    {[24]}    {'epoch' }    {'T/'   }
    {'Longitude'     }    {[ 2 2]}    {[ 1]}    {'int8'  }    {'F/FT' }
    {'Latitude'      }    {[ 2 2]}    {[ 1]}    {'int8'  }    {'F/TF' }
    {'Data'          }    {[ 2 2 4]}  {[ 1]}    {'double'}    {'T/TTT' }
    {'multidimensional'}  {[2 2 3 4]}  {[ 1]}    {'uint8' }    {'T/TTTT'}
    {'Temperature'   }    {[ 3 2]}    {[10]}    {'int16' }    {'T/TT'  }
```

Column 6

```
    {'Full'}
    {'Full'}
    {'Full'}
    {'Full'}
    {'Full'}
    {'Full'}
```

The first variable, `Time`, consists of 24 records containing CDF epoch data. The next two variables, `Longitude` and `Latitude`, each have only one associated record containing `int8` data.

Read All Data from CDF File

Use the `cdfread` function to read all of the data in the CDF file.

```
data = cdfread('example.cdf');
whos data
```

Name	Size	Bytes	Class	Attributes
data	24x6	23904	cell	

`cdfread` returns the data in a cell array. The columns of data correspond to the variables. The rows correspond to the records associated with a variable.

Read Data from Specific Variables

Read only the `Longitude` and `Latitude` variables from the CDF file. To read the data associated with particular variables, use the `'Variable'` parameter. Specify the names of the variables in a cell array of character vectors. Variable names are case sensitive.

```
var_long_lat = cdfread('example.cdf','Variable',{'Longitude','Latitude'});
whos var_long_lat
```

Name	Size	Bytes	Class	Attributes
var_long_lat	1x2	216	cell	

Combine Records to Speed Up Read Operations

By default, `cdfread` creates a cell array with a separate element for every variable and every record in each variable, padding the records dimension to create a rectangular cell array. When working with large data sets, you can speed up read operations by specifying the `'CombineRecords'` parameter to reduce the number of elements in the cell array that `cdfread` returns. When you set the `'CombineRecords'` parameter to `true`, the `cdfread` function creates a separate element for each variable but saves time by putting all the records associated with a variable in a single cell array element.

```
data_combined = cdfread('example.cdf','CombineRecords',true);
```

Compare the sizes of the cell arrays returned by `cdfread`.

```
whos data*
```

Name	Size	Bytes	Class	Attributes
data	24x6	23904	cell	
data_combined	1x6	8080	cell	

Reading all the data from the example file without the `CombineRecords` parameter returns a 24-by-6 cell array, where the columns represent variables and the rows represent the records for each variable. Reading the data from the same file with `'CombineRecords'` set to `true` returns a 1-by-6 cell array.

When combining records, the dimensions of the data in the cell change. In this example, the `Time` variable has 24 records, each of which is a scalar value. In the `data_combined` cell array, the combined element contains a 24-by-1 vector of values.

Read CDF Epoch Values as Serial Date Numbers

By default, `cdfread` creates a MATLAB `cdfepoch` object for each CDF epoch value in the file. Speed up read operations by setting the `'ConvertEpochToDatenum'` name-value pair argument to `true`, to return CDF epoch values as MATLAB serial date numbers.

```
data_datenums = cdfread('example.cdf','ConvertEpochToDatenum',true);  
whos data*
```

Name	Size	Bytes	Class	Attributes
data	24x6	23904	cell	
data_combined	1x6	8080	cell	
data_datenums	24x6	19872	cell	

See Also

`cdfread` | `cdfinfo`

External Websites

- [CDF website](#)

Export to CDF Files

This example shows how to export data to a CDF file using MATLAB® CDF low-level functions. The MATLAB functions correspond to routines in the CDF C API library.

To use the MATLAB CDF low-level functions effectively, you must be familiar with the CDF C interface. Also, CDF files do not support non-ASCII encoded inputs. Therefore, variable names, attributes names, variable values, and attribute values must have 7-bit ASCII encoding.

Create New CDF File

Create a new CDF file named `my_file.cdf` using `cdflib.create`. This function corresponds to the CDF library C API routine, `CDFcreateCDF`.

```
cdfid = cdflib.create('my_file.cdf');
```

`cdflib.create` returns a file identifier, `cdfid`.

Create Variables in CDF File

Create variables named `Time` and `Latitude` using `cdflib.createVar`. This function corresponds to the CDF library C API routine, `CDFcreatezVar`.

```
time_id = cdflib.createVar(cdfid, 'Time', 'cdf_int4', 1, [], true, []);
lat_id = cdflib.createVar(cdfid, 'Latitude', 'cdf_int2', 1, 181, true, true);
```

`cdflib.createVar` returns a numeric identifier for each variable.

Create a variable named `Image`.

```
dimSizes = [20 10];
image_id = cdflib.createVar(cdfid, 'Image', 'cdf_int4', 1, ...
    dimSizes, true, [true true]);
```

Write to Variables

Write data to the first and second records of the `Time` variable. Record numbers are zero-based. The `cdflib.putVarRecordData` function corresponds to the CDF library C API routine, `CDFputzVarRecordData`.

```
cdflib.putVarRecordData(cdfid, time_id, 0, int32(23));
cdflib.putVarRecordData(cdfid, time_id, 1, int32(24));
```

Write data to the `Latitude` variable.

```
data = int16([-90:90]);
recspec = [0 1 1];
dimspec = { 0 181 1 };
cdflib.hyperPutVarData(cdfid, lat_id, recspec, dimspect, data);
```

Write data to the `Image` variable.

```
recspec = [0 3 1];
dimspec = { [0 0], [20 10], [1 1] };
data = reshape(int32([0:599]), [20 10 3]);
cdflib.hyperPutVarData(cdfid, image_id, recspec, dimspect, data);
```

Write to Global Attribute

Create a global attribute named TITLE using `cdflib.createAttr`. This function corresponds to the CDF library C API routine, `CDFcreateAttr`.

```
titleAttrNum = cdflib.createAttr(cdfid, 'TITLE', 'global_scope');
```

`cdflib.createAttr` returns a numeric identifier for the attribute. Attribute numbers are zero-based.

Write values to entries in the global attribute.

```
cdflib.putAttrEntry(cdfid, titleAttrNum, 0, 'CDF_CHAR', 'cdf Title');
cdflib.putAttrEntry(cdfid, titleAttrNum, 1, 'CDF_CHAR', 'Author');
```

Write to Attributes Associated with Variables

Create attributes associated with variables in the CDF file.

```
fieldAttrNum = cdflib.createAttr(cdfid, 'FIELDNAM', 'variable_scope');
unitsAttrNum = cdflib.createAttr(cdfid, 'UNITS', 'variable_scope');
```

Write to attributes of the Time variable.

```
cdflib.putAttrEntry(cdfid, fieldAttrNum, time_id, ...
    'CDF_CHAR', 'Time of observation');
cdflib.putAttrEntry(cdfid, unitsAttrNum, time_id, ...
    'CDF_CHAR', 'Hours');
```

Get Information About CDF File

Get information about the file using `cdflib.inquire`. This function corresponds to the CDF library C API routines, `CDFinquireCDF` and `CDFgetNumAttributes`.

```
info = cdflib.inquire(cdfid)

info = struct with fields:
    encoding: 'IBMPC_ENCODING'
    majority: 'ROW_MAJOR'
    maxRec: 2
    numVars: 3
    numvAttrs: 2
    numgAttrs: 1
```

`cdflib.inquire` returns a structure array that includes information about the data encoding and the number of variables and attributes in the file.

Close CDF File

Close the CDF File using `cdflib.close`. This function corresponds to the CDF library C API routine, `CDFcloseCDF`. You must close a CDF to guarantee that all modifications you made since opening the CDF are written to the file.

```
cdflib.close(cdfid);
```

See Also

`cdflib`

External Websites

- CDF website

Map NetCDF API Syntax to MATLAB Syntax

MATLAB provides access to the routines in the NetCDF C library through a set of low-level functions that are grouped into a package called `netcdf`. Use the functions in this package to read and write data to and from NetCDF files. To use the MATLAB NetCDF functions effectively, you should be familiar with the NetCDF C interface.

Usually, the MATLAB functions in the `netcdf` package correspond directly to routines in the NetCDF C library. For example, the MATLAB function `netcdf.open` corresponds to the NetCDF library routine `nc_open`. In some cases, one MATLAB function corresponds to a group of NetCDF library functions. For example, instead of creating MATLAB versions of every NetCDF library `nc_put_att_type` function, where *type* represents a data type, MATLAB uses one function, `netcdf.putAtt`, to handle all supported data types.

To call one of the functions in the `netcdf` package, you must prefix the function name with the package name. The syntax of the MATLAB functions is similar to the NetCDF library routines. However, the NetCDF C library routines use input parameters to return data, while their MATLAB counterparts use one or more return values. For example, this is the function signature of the `nc_open` routine in the NetCDF library:

```
int nc_open (const char *path, int omode, int *ncidp); /* C syntax */
```

The NetCDF file identifier is returned in the `ncidp` argument.

This is the signature of the corresponding MATLAB function, `netcdf.open`:

```
ncid = netcdf.open(filename,mode)
```

Like its NetCDF C library counterpart, the MATLAB NetCDF function accepts a file name and a constant that specifies the access mode. However, the MATLAB `netcdf.open` function returns the file identifier, `ncid`, as a return value.

The MATLAB NetCDF functions automatically choose the MATLAB class that best matches the NetCDF data type. This table shows the default mapping.

NetCDF Data Type	MATLAB Class
NC_DOUBLE	double
NC_FLOAT	single
NC_INT64 (NetCDF-4 files only)	int64
NC_UINT64 (NetCDF-4 files only)	uint64
NC_INT	int32
NC_UINT (NetCDF-4 files only)	uint32
NC_SHORT	int16
NC_USHORT (NetCDF-4 files only)	uint16
NC_BYTE	int8
NC_UBYTE (NetCDF-4 files only)	uint8
NC_CHAR	char
NC_STRING (NetCDF-4 files only)	string

NetCDF Data Type	MATLAB Class
User-defined NC_VLEN types (NetCDF-4 files only)	cell

You can override the default and specify the class of the return data by using an optional argument to the `netcdf.getVar` function.

See Also

More About

- “Import NetCDF Files and OPeNDAP Data” on page 7-13
- “Export to NetCDF Files” on page 7-21

External Websites

- NetCDF website

Import NetCDF Files and OPeNDAP Data

Read data from a NetCDF file using the high-level functions, and then read the file by using the `netcdf` package low-level functions.

In this section...

“MATLAB NetCDF Capabilities” on page 7-13

“Security Considerations When Connecting to an OPeNDAP Server” on page 7-13

“Read from NetCDF File Using High-Level Functions” on page 7-13

“Find All Unlimited Dimensions in NetCDF File” on page 7-15

“Read from NetCDF File Using Low-Level Functions” on page 7-16

MATLAB NetCDF Capabilities

Network Common Data Form (NetCDF) is a set of software libraries and machine-independent data formats that support the creation, access, and sharing of array-oriented scientific data. NetCDF is used by a wide range of engineering and scientific fields that want a standard way to store data so that it can be shared.

MATLAB high-level functions simplify the process of importing data from a NetCDF file or an OPeNDAP NetCDF data source. MATLAB low-level functions enable more control over the importing process, by providing access to the routines in the NetCDF C library. To use the low-level functions effectively, you should be familiar with the NetCDF C Interface. The NetCDF documentation is available at the Unidata website.

Note For information about importing Common Data Format (CDF) files, which have a separate, incompatible format, see “Import CDF Files Using Low-Level Functions” on page 7-2.

Security Considerations When Connecting to an OPeNDAP Server

It is highly recommended that you connect only to trusted OPeNDAP servers. In R2020b, the MATLAB NetCDF interface connects only to trusted data access protocol (DAP) endpoints by default by performing server certificate and host name validations. Previously, when you accessed an OPeNDAP server, both the server certificate and host name validation were disabled by default.

If you would like to disable the server certificate and host name validation, add the following line in a `.dodsrc` file in the current directory:

```
[mylocaltestserver.lab] HTTP.SSL.VALIDATE=0
```

This makes the MATLAB NetCDF interface connect to the OPeNDAP server whose name is specified in the URI `mylocaltestserver.lab` without performing any validations on the server certificate or host name. This change persists in future MATLAB sessions. For more information on OPeNDAP server authentication and host name validation, see [netCDF Authorization Support](#).

Read from NetCDF File Using High-Level Functions

This example shows how to display and read the contents of a NetCDF file, using high-level functions.

Display the contents of the sample NetCDF file, `example.nc`.

```
ncdisp('example.nc')
```

```
Source:      \\matlabroot\toolbox\matlab\demos\example.nc
Format:      netcdf4
Global Attributes:
  creation_date = '29-Mar-2010'
Dimensions:
  x = 50
  y = 50
  z = 5
Variables:
  avagadros_number
    Size:      1x1
    Dimensions:
    Datatype:  double
    Attributes:
      description = 'this variable has no dimensions'
  temperature
    Size:      50x1
    Dimensions: x
    Datatype:  int16
    Attributes:
      scale_factor = 1.8
      add_offset   = 32
      units        = 'degrees_fahrenheit'
  peaks
    Size:      50x50
    Dimensions: x,y
    Datatype:  int16
    Attributes:
      description = 'z = peaks(50);'
Groups:
  /grid1/
    Attributes:
      description = 'This is a group attribute.'
    Dimensions:
      x      = 360
      y      = 180
      time = 0      (UNLIMITED)
    Variables:
      temp
        Size:      []
        Dimensions: x,y,time
        Datatype:  int16
  /grid2/
    Attributes:
      description = 'This is another group attribute.'
    Dimensions:
      x      = 360
      y      = 180
      time = 0      (UNLIMITED)
    Variables:
      temp
```

```

Size:      []
Dimensions: x,y,time
Datatype:  int16

```

`ncdisp` displays all the groups, dimensions, and variable definitions in the file. Unlimited dimensions are identified with the label, `UNLIMITED`.

Read data from the `peaks` variable.

```
peaksData = ncread('example.nc', 'peaks');
```

Display information about the `peaksData` output.

```
whos peaksData
```

Name	Size	Bytes	Class	Attributes
peaksData	50x50	5000	int16	

Read the `description` attribute associated with the variable.

```
peaksDesc = ncreadatt('example.nc', 'peaks', 'description')
```

```
peaksDesc =
```

```
z = peaks(50);
```

Create a three-dimensional surface plot of the variable data. Use the value of the `description` attribute as the title of the figure.

```
surf(double(peaksData))
title(peaksDesc);
```

Read the `description` attribute associated with the `/grid1/` group. Specify the group name as the second input to the `ncreadatt` function.

```
g = ncreadatt('example.nc', '/grid1/', 'description')
```

```
g =
```

```
This is a group attribute.
```

Read the global attribute, `creation_date`. For global attributes, specify the second input argument to `ncreadatt` as `'/'`.

```
creation_date = ncreadatt('example.nc', '/', 'creation_date')
```

```
creation_date =
```

```
29-Mar-2010
```

Find All Unlimited Dimensions in NetCDF File

This example shows how to find all unlimited dimensions in a group in a NetCDF file, using high-level functions.

Get information about the `/grid2/` group in the sample file, `example.nc`, using the `ncinfo` function.

```
ginfo = ncinfo('example.nc','/grid2/')
ginfo =
    Filename: '\\matlabroot\toolbox\matlab\demos\example.nc'
      Name: 'grid2'
  Dimensions: [1x3 struct]
  Variables: [1x1 struct]
  Attributes: [1x1 struct]
     Groups: []
   Format: 'netcdf4'
```

`ncinfo` returns a structure array containing information about the group.

Get a vector of the Boolean values that indicate the unlimited dimensions for this group.

```
unlimDims = [ginfo.Dimensions.Unlimited]
unlimDims =
    0    0    1
```

Use the `unlimDims` vector to display the unlimited dimension.

```
disp(ginfo.Dimensions(unlimDims))
    Name: 'time'
  Length: 0
Unlimited: 1
```

Read from NetCDF File Using Low-Level Functions

This example shows how to get information about the dimensions, variables, and attributes in a NetCDF file using MATLAB low-level functions in the `netcdf` package. To use these functions effectively, you should be familiar with the NetCDF C Interface.

Open NetCDF File

Open the sample NetCDF file, `example.nc`, using the `netcdf.open` function, with read-only access.

```
ncid = netcdf.open('example.nc','NC_NOWRITE')
ncid = 65536
```

`netcdf.open` returns a file identifier.

Get Information About NetCDF File

Get information about the contents of the file using the `netcdf.inq` function. This function corresponds to the `nc_inq` function in the NetCDF library C API.

```
[ndims,nvars,natts,unlimdimID] = netcdf.inq(ncid)
ndims = 3
nvars = 3
natts = 1
```



```
unlimdimID = -1
```

`netcdf.inq` returns the number of dimensions, variables, and global attributes in the file, and returns the identifier of the unlimited dimension in the file. An unlimited dimension can grow.

Get the name of the global attribute in the file using the `netcdf.inqAttName` function. This function corresponds to the `nc_inq_attname` function in the NetCDF library C API. To get the name of an attribute, you must specify the ID of the variable the attribute is associated with and the attribute number. To access a global attribute, which is not associated with a particular variable, use the constant `'NC_GLOBAL'` as the variable ID.

```
global_att_name = netcdf.inqAttName(ncid, ...
    netcdf.getConstant('NC_GLOBAL'),0)
```

```
global_att_name =
'creation_date'
```

Get information about the data type and length of the attribute using the `netcdf.inqAtt` function. This function corresponds to the `nc_inq_att` function in the NetCDF library C API. Again, specify the variable ID using `netcdf.getConstant('NC_GLOBAL')`.

```
[xtype,attlen] = netcdf.inqAtt(ncid, ...
    netcdf.getConstant('NC_GLOBAL'),global_att_name)
```

```
xtype = 2
```

```
attlen = 11
```

Get the value of the attribute, using the `netcdf.getAtt` function.

```
global_att_value = netcdf.getAtt(ncid, ...
    netcdf.getConstant('NC_GLOBAL'),global_att_name)
```

```
global_att_value =
'29-Mar-2010'
```

Get information about the first dimension in the file, using the `netcdf.inqDim` function. This function corresponds to the `nc_inq_dim` function in the NetCDF library C API. The second input to `netcdf.inqDim` is the dimension ID, which is a zero-based index that identifies the dimension. The first dimension has the index value 0.

```
[dimname,dimlen] = netcdf.inqDim(ncid,0)
```

```
dimname =
'x'
```

```
dimlen = 50
```

`netcdf.inqDim` returns the name and length of the dimension.

Get information about the first variable in the file using the `netcdf.inqVar` function. This function corresponds to the `nc_inq_var` function in the NetCDF library C API. The second input to `netcdf.inqVar` is the variable ID, which is a zero-based index that identifies the variable. The first variable has the index value 0.

```
[varname,vartype,dimids,natts] = netcdf.inqVar(ncid,0)
```

```
varname =
'avagadros_number'
```

```
vartype = 6
dimids =
    []
natts = 1
```

`netcdf.inqVar` returns the name, data type, dimension ID, and the number of attributes associated with the variable. The data type information returned in `vartype` is the numeric value of the NetCDF data type constants, such as, `NC_INT` and `NC_BYTE`. See the NetCDF documentation for information about these constants.

Read Data from NetCDF File

Read the data associated with the variable, `avagadros_number`, in the example file, using the `netcdf.getVar` function. The second input to `netcdf.getVar` is the variable ID, which is a zero-based index that identifies the variable. The `avagadros_number` variable has the index value 0.

```
A_number = netcdf.getVar(ncid,0)
A_number = 6.0221e+23
```

View the data type of `A_number`.

```
whos A_number
```

Name	Size	Bytes	Class	Attributes
A_number	1x1	8	double	

The functions in the `netcdf` package automatically choose the MATLAB class that best matches the NetCDF data type, but you can also specify the class of the return data by using an optional argument to `netcdf.getVar`.

Read the data associated with `avagadros_number` and return the data as class `single`.

```
A_number = netcdf.getVar(ncid,0,'single');
whos A_number
```

Name	Size	Bytes	Class	Attributes
A_number	1x1	4	single	

Close NetCDF File

Close the NetCDF file, `example.nc`.

```
netcdf.close(ncid)
```

See Also

`ncread` | `ncreadatt` | `ncdisp` | `ncinfo`

More About

- “Map NetCDF API Syntax to MATLAB Syntax” on page 7-11

External Websites

- NetCDF C Interface

Resolve Errors Reading OPeNDAP Data

When you have trouble reading OPeNDAP data, consider these factors.

- OPeNDAP data is being pulled over the network from a server on the Internet. Pulling large data could be slow. Speed and reliability depend on their network connection.
- Failure to open an OPeNDAP link could have multiple causes.
 - URL is invalid.
 - Local machine firewall or network firewall does not allow any external connections.
 - Local machine firewall or network firewall does not allow and external connections on the OPeNDAP protocol.
 - Remote server is down.
 - Remote server will not serve the amount of data being requested. (In this case, you can read data in subsets or chunks.)
 - Remote server is incorrectly configured.

Export to NetCDF Files

Create, merge, and write NetCDF files using high-level functions and the `netcdf` package low-level functions.

In this section...

“MATLAB NetCDF Capabilities” on page 7-21

“Create New NetCDF File from Existing File or Template” on page 7-21

“Merge Two NetCDF Files” on page 7-22

“Write Data to NetCDF File Using Low-Level Functions” on page 7-24

MATLAB NetCDF Capabilities

Network Common Data Form (NetCDF) is a set of software libraries and machine-independent data formats that support the creation, access, and sharing of array-oriented scientific data. NetCDF is used by a wide range of engineering and scientific fields that want a standard way to store data so that it can be shared.

MATLAB high-level functions make it easy to export data to a netCDF file. MATLAB low-level functions provide access to the routines in the NetCDF C library. To use the low-level functions effectively, you should be familiar with the NetCDF C Interface. The NetCDF documentation is available at the Unidata website.

Note For information about exporting to Common Data Format (CDF) files, which have a separate and incompatible format, see “Export to CDF Files” on page 7-8.

Create New NetCDF File from Existing File or Template

This example shows how to create a new NetCDF file that contains the variable, dimension, and group definitions of an existing file, but uses a different format.

Create a file containing one variable, using the `nccreate` function.

```
nccreate('myfile.nc', 'myvar')
```

Write data to the file.

```
A = 99;
ncwrite('myfile.nc', 'myvar', A)
```

Read the variable, dimension, and group definitions from the file using `ncinfo`. This information defines the file's *schema*.

```
S = ncinfo('myfile.nc');
```

Get the format of the file.

```
file_fmt = S.Format
```

```
file_fmt =  
'netcdf4_classic'
```

Change the value of the Format field in the structure, *S*, to another supported NetCDF format.

```
S.Format = 'netcdf4';
```

Create a new version of the file that uses the new format, using the `ncwritschema` function. A schema defines the structure of the file but does not contain any of the data that was in the original file.

```
ncwritschema('newfile.nc',S)  
S = ncinfo('newfile.nc');
```

Note: When you convert a file's format using `ncwritschema`, you might get a warning message if the original file format includes fields that are not supported by the new format. For example, the `netcdf4` format supports fill values but the NetCDF classic format does not. In these cases, `ncwritschema` still creates the file, but omits the field that is undefined in the new format.

View the format of the new file.

```
new_fmt = S.Format  
  
new_fmt =  
'netcdf4'
```

The new file, `newfile.nc`, contains the variable and dimension definitions of `myfile.nc`, but does not contain the data.

Write data to the new file.

```
ncwrite('newfile.nc','myvar',A)
```

Merge Two NetCDF Files

This example shows how to merge two NetCDF files using high-level functions. The combined file contains the variable and dimension definitions of the files that are combined, but does not contain the data in these original files.

Create a NetCDF file named `ex1.nc` and define a variable named `myvar`. Then, write data to the variable and display the file contents.

```
nccreate('ex1.nc','myvar');  
ncwrite('ex1.nc','myvar',55)  
ncdisp('ex1.nc')
```

```
Source:  
    pwd\ex1.nc  
Format:  
    netcdf4_classic  
Variables:  
    myvar  
      Size:      1x1  
      Dimensions:  
      Datatype:  double
```

Create a second file and define a variable named `myvar2`. Then, write data to the variable and display the file contents.

```
nccreate('ex2.nc', 'myvar2');
ncwrite('ex2.nc', 'myvar2', 99)
ncdisp('ex2.nc')
```

```
Source:
      pwd\ex2.nc
Format:
      netcdf4_classic
Variables:
  myvar2
      Size:      1x1
      Dimensions:
      Datatype:  double
```

Get the schema of each of the files, using the `ncinfo` function.

```
info1 = ncinfo('ex1.nc')
info1 =
      Filename: 'pwd\ex1.nc'
      Name: '/'
      Dimensions: []
      Variables: [1x1 struct]
      Attributes: []
      Groups: []
      Format: 'netcdf4_classic'

info2 = ncinfo('ex2.nc')
info2 =
      Filename: 'pwd\ex2.nc'
      Name: '/'
      Dimensions: []
      Variables: [1x1 struct]
      Attributes: []
      Groups: []
      Format: 'netcdf4_classic'
```

Create a new NetCDF file that uses the schema of the first example file, using the `ncwritschema` function. Then, display the file contents.

```
ncwritschema('combined.nc', info1)
ncdisp('combined.nc')
```

```
Source:
      pwd\combined.nc
Format:
      netcdf4_classic
Variables:
  myvar
      Size:      1x1
      Dimensions:
      Datatype:  double
```

```
Attributes:
    _FillValue = 9.969209968386869e+36
```

Add the schema from `ex2.nc` to `combined.nc`, using `ncwritschema`.

```
ncwritschema('combined.nc',info2)
```

View the contents of the combined file.

```
ncdisp('combined.nc')
```

```
Source:
    pwd\combined.nc
Format:
    netcdf4_classic
Variables:
    myvar
        Size:          1x1
        Dimensions:
        Datatype:      double
        Attributes:
            _FillValue = 9.969209968386869e+36
    myvar2
        Size:          1x1
        Dimensions:
        Datatype:      double
        Attributes:
            _FillValue = 9.969209968386869e+36
```

The file contains the `myvar` variable defined in the first example file and the `myvar2` variable defined in the second file.

Write Data to NetCDF File Using Low-Level Functions

This example shows how to use low-level functions to write data to a NetCDF file. The MATLAB® low-level functions provide access to the routines in the NetCDF C library. MATLAB groups the functions into a package, called `netcdf`. To call one of the functions in the package, you must prefix the function name with the package name.

To use the MATLAB NetCDF functions effectively, you should be familiar with the information about the NetCDF C Interface.

To run this example, you must have write permission in your current folder.

Create a 1-by-50 variable of numeric values named `my_data` in the MATLAB workspace. The vector is of class `double`.

```
my_data = linspace(0,49,50);
```

Create a NetCDF file named `my_file.nc`, using the `netcdf.create` function. The `NOCLOBBER` parameter is a NetCDF file access constant that indicates that you do not want to overwrite an existing file with the same name.

```
ncid = netcdf.create('my_file.nc','NOCLOBBER');
```

`netcdf.create` returns a file identifier, `ncid`. When you create a NetCDF file, the file opens in define mode. You must be in define mode to define dimensions and variables.

Define a dimension in the file, using the `netcdf.defDim` function. This function corresponds to the `nc_def_dim` function in the NetCDF library C API. You must define dimensions in the file before you can define variables and write data to the file. In this case, define a dimension named `my_dim` with length 50.

```
dimid = netcdf.defDim(ncid, 'my_dim', 50)
dimid = 0
```

`netcdf.defDim` returns a dimension identifier that corresponds to the new dimension. Identifiers are zero-based indexes.

Define a variable named `my_var` on the dimension, using the `netcdf.defVar` function. This function corresponds to the `nc_def_var` function in the NetCDF library C API. Specify the NetCDF data type of the variable, in this case, `NC_BYTE`.

```
varid = netcdf.defVar(ncid, 'my_var', 'NC_BYTE', dimid)
varid = 0
```

`netcdf.defVar` returns a variable identifier that corresponds to `my_var`.

Take the NetCDF file out of define mode. To write data to a file, you must be in data mode.

```
netcdf.endDef(ncid)
```

Write the data from the MATLAB workspace into the variable in the NetCDF file, using the `netcdf.putVar` function. The data in the workspace is of class `double` but the variable in the NetCDF file is of type `NC_BYTE`. The MATLAB NetCDF functions automatically do the conversion.

```
netcdf.putVar(ncid, varid, my_data)
```

Close the file, using the `netcdf.close` function.

```
netcdf.close(ncid)
```

Verify that the data was written to the file by opening the file and reading the data from the variable into a new variable in the MATLAB workspace.

```
ncid2 = netcdf.open('my_file.nc', 'NC_NOWRITE');
x = netcdf.getVar(ncid2, 0);
```

View the data type of `x`.

```
whos x
```

Name	Size	Bytes	Class	Attributes
x	50x1	50	int8	

MATLAB stores data in column-major order while the NetCDF C API uses row-major order. `x` represents the data stored in the NetCDF file and is therefore 50-by-1 even though the original vector in the MATLAB workspace, `my_data`, is 1-by-50. Because you stored the data in the NetCDF file as `NC_BYTE`, MATLAB reads the data from the variable into the workspace as class `int8`.

Close the file.

```
netcdf.close(ncid2)
```

See Also

More About

- “Map NetCDF API Syntax to MATLAB Syntax” on page 7-11

External Websites

- [NetCDF C Interface](#)

Importing Flexible Image Transport System (FITS) Files

The FITS file format is the standard data format used in astronomy, endorsed by both NASA and the International Astronomical Union (IAU). For more information about the FITS standard, go to the FITS Web site, <https://fits.gsfc.nasa.gov/>.

The FITS file format is designed to store scientific data sets consisting of multidimensional arrays (1-D spectra, 2-D images, or 3-D data cubes) and two-dimensional tables containing rows and columns of data. A data file in FITS format can contain multiple components, each marked by an ASCII text header followed by binary data. The first component in a FITS file is known as the *primary*, which can be followed by any number of other components, called *extensions*, in FITS terminology. For a complete list of extensions, see `fitsread`.

To get information about the contents of a Flexible Image Transport System (FITS) file, use the `fitsinfo` function. The `fitsinfo` function returns a structure containing the information about the file and detailed information about the data in the file.

To import data into the MATLAB workspace from a Flexible Image Transport System (FITS) file, use the `fitsread` function. Using this function, you can import the primary data in the file or you can import the data in any of the extensions in the file, such as the Image extension, as shown in this example.

- 1 Determine which extensions the FITS file contains, using the `fitsinfo` function.

```
info = fitsinfo('tst0012.fits')

info =

    Filename: 'matlabroot\tst0012.fits'
   FileModDate: '12-Mar-2001 19:37:46'
    FileSize: 109440
   Contents: {'Primary' 'Binary Table' 'Unknown' 'Image' 'ASCII Table'}
  PrimaryData: [1x1 struct]
  BinaryTable: [1x1 struct]
        Unknown: [1x1 struct]
           Image: [1x1 struct]
    AsciiTable: [1x1 struct]
```

The `info` structure shows that the file contains several extensions including the Binary Table, ASCII Table, and Image extensions.

- 2 Read data from the file.

To read the Primary data in the file, specify the filename as the only argument:

```
pdata = fitsread('tst0012.fits');
```

To read any of the extensions in the file, you must specify the name of the extension as an optional parameter. This example reads the Binary Table extension from the FITS file:

```
bindata = fitsread('tst0012.fits','binarytable');
```

Import HDF5 Files

In this section...
“Overview” on page 7-28
“Import Data Using High-Level HDF5 Functions” on page 7-28
“Import Data Using Low-Level HDF5 Functions” on page 7-33
“Read HDF5 Data Set Using Dynamically Loaded Filters” on page 7-33

Overview

Hierarchical Data Format, Version 5, (HDF5) is a general-purpose, machine-independent standard for storing scientific data in files, developed by the National Center for Supercomputing Applications (NCSA). HDF5 is used by a wide range of engineering and scientific fields that want a standard way to store data so that it can be shared. For more information about the HDF5 file format, read the HDF5 documentation available at The HDF Group website (<https://www.hdfgroup.org>).

MATLAB provides two methods to import data from an HDF5 file:

- High-level functions that make it easy to import data, when working with numeric data sets
- Low-level functions that enable more complete control over the importing process, by providing access to the routines in the HDF5 C library

Note For information about importing to HDF4 files, which have a separate, incompatible format, see “Import HDF4 Files Programmatically” on page 7-44.

Import Data Using High-Level HDF5 Functions

MATLAB includes several functions that you can use to examine the contents of an HDF5 file and import data from the file into the MATLAB workspace.

Note You can use only the high-level functions to read numeric data sets or attributes. To read non-numeric data sets or attributes, you must use the low-level interface on page 7-33.

- `h5disp` — View the contents of an HDF5 file.
- `h5info` — Create a structure that contains all the metadata defining an HDF5 file.
- `h5read` — Read data from a variable in an HDF5 file.
- `h5readatt` — Read data from an attribute associated with a variable in an HDF5 file or with the file itself (a global attribute).

For details about how to use these functions, see their reference pages, which include examples. The following sections illustrate some common usage scenarios.

Determine Contents of HDF5 File

HDF5 files can contain data and metadata, called *attributes*. HDF5 files organize the data and metadata in a hierarchical structure similar to the hierarchical structure of a UNIX file system.

In an HDF5 file, the directories in the hierarchy are called *groups*. A group can contain other groups, data sets, attributes, links, and data types. A data set is a collection of data, such as a multidimensional numeric array or string. An attribute is any data that is associated with another entity, such as a data set. A link is similar to a UNIX file system symbolic link. Links are a way to reference objects without having to make a copy of the object.

Data types are a description of the data in the data set or attribute. Data types tell how to interpret the data in the data set.

To get a quick view into the contents of an HDF5 file, use the `h5disp` function.

```
h5disp('example.h5')
```

```
HDF5 example.h5
Group '/'
  Attributes:
    'attr1':  97 98 99 100 101 102 103 104 105 0
    'attr2':  2x2 H5T_INTEGER
  Group '/g1'
    Group '/g1/g1.1'
      Dataset 'dset1.1.1'
        Size: 10x10
        MaxSize: 10x10
        Datatype:  H5T_STD_I32BE (int32)
        ChunkSize:  []
        Filters:  none
        Attributes:
          'attr1':  49 115 116 32 97 116 116 114 105 ...
          'attr2':  50 110 100 32 97 116 116 114 105 ...
      Dataset 'dset1.1.2'
        Size: 20
        MaxSize: 20
        Datatype:  H5T_STD_I32BE (int32)
        ChunkSize:  []
        Filters:  none
    Group '/g1/g1.2'
      Group '/g1/g1.2/g1.2.1'
        Link 'slink'
        Type:  soft link
  Group '/g2'
    Dataset 'dset2.1'
      Size: 10
      MaxSize: 10
      Datatype:  H5T_IEEE_F32BE (single)
      ChunkSize:  []
      Filters:  none
    Dataset 'dset2.2'
      Size: 5x3
      MaxSize: 5x3
      Datatype:  H5T_IEEE_F32BE (single)
      ChunkSize:  []
      Filters:  none
      .
      .
      .
```

To explore the hierarchical organization of an HDF5 file, use the `h5info` function. `h5info` returns a structure that contains various information about the HDF5 file, including the name of the file.

```

info = h5info('example.h5')
info =

    Filename: 'matlabroot\matlab\toolbox\matlab\demos\example.h5'
    Name: '/'
    Groups: [4x1 struct]
    Datasets: []
    Datatypes: []
    Links: []
    Attributes: [2x1 struct]

```

By looking at the `Groups` and `Attributes` fields, you can see that the file contains four groups and two attributes. The `Datasets`, `Datatypes`, and `Links` fields are all empty, indicating that the root group does not contain any data sets, data types, or links. To explore the contents of the sample HDF5 file further, examine one of the structures in `Groups`. The following example shows the contents of the second structure in this field.

```

level2 = info.Groups(2)
level2 =

    Name: '/g2'
    Groups: []
    Datasets: [2x1 struct]
    Datatypes: []
    Links: []
    Attributes: []

```

In the sample file, the group named `/g2` contains two data sets. The following figure illustrates this part of the sample HDF5 file organization.

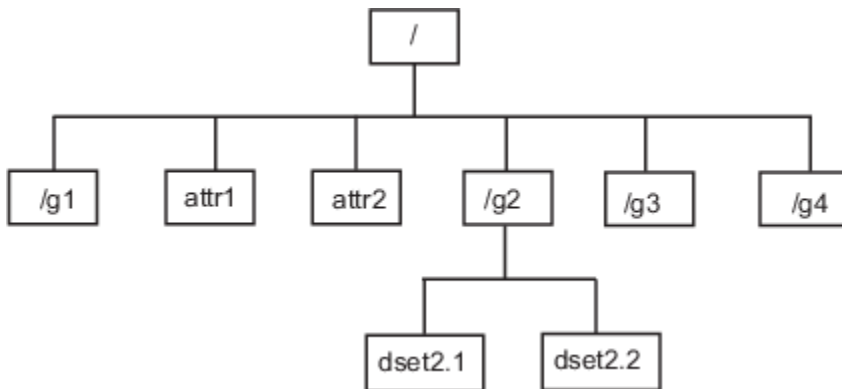

To get information about a data set, such as its name, dimensions, and data type, look at either of the structures returned in the `Datasets` field.

```

dataset1 = level2.Datasets(1)
dataset1 =

    Filename: 'matlabroot\example.h5'
    Name: '/g2/dset2.1'
    Rank: 1
    Datatype: [1x1 struct]
    Dims: 10
    MaxDims: 10

```

```

    Layout: 'contiguous'
Attributes: []
    Links: []
    Chunksize: []
    Fillvalue: []

```

Import Data from HDF5 File

To read data or metadata from an HDF5 file, use the `h5read` function. As arguments, specify the name of the HDF5 file and the name of the data set. (To read the value of an attribute, you must use `h5readatt`.)

To illustrate, this example reads the data set, `/g2/dset2.1` from the HDF5 sample file `example.h5`.

```
data = h5read('example.h5', '/g2/dset2.1')
```

```
data =
```

```

    1.0000
    1.1000
    1.2000
    1.3000
    1.4000
    1.5000
    1.6000
    1.7000
    1.8000
    1.9000

```

Map HDF5 Data Types to MATLAB Data Types

When the `h5read` function reads data from an HDF5 file into the MATLAB workspace, it maps HDF5 data types to MATLAB data types, as shown in the table below.

HDF5 Data Type	h5read Returns
Bit-field	Array of packed 8-bit integers
Float	MATLAB single and double types, provided that they occupy 64 bits or fewer
Integer types, signed and unsigned	Equivalent MATLAB integer types, signed and unsigned
Opaque	Array of <code>uint8</code> values
Reference	Returns the actual data pointed to by the reference, not the value of the reference.
Strings, fixed-length and variable length	String arrays.
Enums	Cell array of character vectors, where each enumerated value is replaced by the corresponding member name
Compound	1-by-1 struct array; the dimensions of the data set are expressed in the fields of the structure.
Arrays	Array of values using the same data type as the HDF5 array. For example, if the array is of signed 32-bit integers, the MATLAB array will be of type <code>int32</code> .

The example HDF5 file included with MATLAB includes examples of all these data types.

For example, the data set `/g3/string` is a string.

```
h5disp('example.h5','/g3/string')
HDF5 example.h5
Dataset 'string'
  Size: 2
  MaxSize: 2
  Datatype:  H5T_STRING
    String Length: 3
    Padding: H5T_STR_NULLTERM
    Character Set: H5T_CSET_ASCII
    Character Type: H5T_C_S1
  ChunkSize: []
  Filters: none
  FillValue: ''
```

Now read the data from the file, MATLAB returns it as a cell array of character vectors.

```
s = h5read('example.h5','/g3/string')

s =

    'ab '
    'de '

>> whos s
  Name      Size      Bytes  Class  Attributes
  s         2x1         236   cell
```

The compound data types are always returned as a 1-by-1 struct. The dimensions of the data set are expressed in the fields of the struct. For example, the data set `/g3/compound2D` is a compound data type.

```
h5disp('example.h5','/g3/compound2D')
HDF5 example.h5
Dataset 'compound2D'
  Size: 2x3
  MaxSize: 2x3
  Datatype:  H5T_COMPOUND
    Member 'a':  H5T_STD_I8LE (int8)
    Member 'b':  H5T_IEEE_F64LE (double)
  ChunkSize: []
  Filters: none
  FillValue:  H5T_COMPOUND
```

Now read the data from the file, MATLAB returns it as a 1-by-1 struct.

```
data = h5read('example.h5','/g3/compound2D')

data =

    a: [2x3 int8]
    b: [2x3 double]
```

Import Data Using Low-Level HDF5 Functions

MATLAB provides direct access to dozens of functions in the HDF5 library with *low-level* functions that correspond to the functions in the HDF5 library. In this way, you can access the features of the HDF5 library from MATLAB, such as reading and writing complex data types and using the HDF5 subsetting capabilities. For more information, see “Export Data Using MATLAB Low-Level HDF5 Functions” on page 7-35.

Read HDF5 Data Set Using Dynamically Loaded Filters

MATLAB supports reading and writing HDF5 data sets using dynamically loaded filters. The HDF Group maintains a list of registered filters at Filters on their website.

To read a data set that has been written using a user-defined, third-party filter, follow these steps:

- 1 Install the HDF5 filter plugin on your system as a shared library or DLL.
- 2 Set the `HDF5_PLUGIN_PATH` environment variable to the folder containing the installed plugin binary file. On a Windows system, use the `setenv` command in MATLAB. On a Linux or Mac system, perform this action in a terminal window before you start MATLAB.

After you complete these steps, you can use the high-level or low-level MATLAB HDF5 functions to read and access data sets that have been compressed using the third-party filter. For more information, see HDF5 Dynamically Loaded Filters on The HDF Group website.

Linux Users Only: Rebuild Filter Plugins Using MATLAB HDF5 Shared Library

Starting in R2021b, in certain cases, Linux users using a filter plugin with callbacks to core HDF5 library functions must rebuild the plugin using the shipping MATLAB HDF5 shared library, `/matlab/bin/glnxa64/libhdf5.so.x.x.x`. If you do not rebuild the plugin using this version of the shared library, you might experience issues ranging from undefined behavior to crashes. For more information, see Build HDF5 Filter Plugins on Linux Using MATLAB HDF5 Shared Library or GNU Export Map.

See Also

Related Examples

- “Export to HDF5 Files” on page 7-34

Export to HDF5 Files

In this section...

“Overview” on page 7-34

“Export Data Using MATLAB High-Level HDF5 Functions” on page 7-34

“Export Data Using MATLAB Low-Level HDF5 Functions” on page 7-35

“Write HDF5 Data Set Using Dynamically Loaded Filters” on page 7-40

Overview

Hierarchical Data Format, Version 5, (HDF5) is a general-purpose, machine-independent standard for storing scientific data in files, developed by the National Center for Supercomputing Applications (NCSA). HDF5 is used by a wide range of engineering and scientific fields that want a standard way to store data so that it can be shared. For more information about the HDF5 file format, read the HDF5 documentation available at The HDF Group website (<https://www.hdfgroup.org>).

MATLAB provides two methods to export data to an HDF5 file:

- High-level functions that simplify the process of exporting data, when working with numeric data sets
- Low-level functions that provide a MATLAB interface to routines in the HDF5 C library

Note For information about exporting to HDF4 files, which have a separate and incompatible format, see “Export to HDF4 Files” on page 7-69.

Export Data Using MATLAB High-Level HDF5 Functions

The easiest way to write data or metadata from the MATLAB workspace to an HDF5 file is to use these MATLAB high-level functions.

Note You can use the high-level functions only with numeric data. To write nonnumeric data, you must use the low-level interface on page 7-35.

- `h5create` — Create an HDF5 data set.
- `h5write` — Write data to an HDF5 data set.
- `h5writeatt` — Write data to an HDF5 attribute.

For details about how to use these functions, see their reference pages, which include examples. The following sections illustrate some common usage scenarios.

Write Numeric Array to HDF5 Data Set

This example creates an array and then writes the array to an HDF5 file.

- 1 Create a MATLAB variable in the workspace. This example creates a 5-by-5 array of `uint8` values.

```
testdata = uint8(magic(5))
```

- 2 Create the HDF5 file and the data set, using `h5create`.

```
h5create('my_example_file.h5', '/dataset1', size(testdata))
```

- 3 Write the data to the HDF5 file.

```
h5write('my_example_file.h5', '/dataset1', testdata)
```

Export Data Using MATLAB Low-Level HDF5 Functions

MATLAB provides direct access to dozens of functions in the HDF5 library with *low-level* functions that correspond to the functions in the HDF5 library. In this way, you can access the features of the HDF5 library from MATLAB, such as reading and writing complex data types and using the HDF5 subsetting capabilities.

The HDF5 library organizes the library functions into collections, called *interfaces*. For example, all the routines related to working with files, such as opening and closing, are in the H5F interface, where *F* stands for file. MATLAB organizes the low-level HDF5 functions into classes that correspond to each HDF5 interface. For example, the MATLAB functions that correspond to the HDF5 file interface (H5F) are in the `@H5F` class folder.

The following sections provide more detail about how to use the MATLAB HDF5 low-level functions.

Note This topic does not describe all features of the HDF5 library or explain basic HDF5 programming concepts. To use the MATLAB HDF5 low-level functions effectively, refer to the official HDF5 documentation available at <https://www.hdfgroup.org>.

Map HDF5 Function Syntax to MATLAB Function Syntax

In most cases, the syntax of the MATLAB low-level HDF5 functions matches the syntax of the corresponding HDF5 library functions. For example, the following is the function signature of the `H5Fopen` function in the HDF5 library. In the HDF5 function signatures, `hid_t` and `herr_t` are HDF5 types that return numeric values that represent object identifiers or error status values.

```
hid_t H5Fopen(const char *name, unsigned flags, hid_t access_id) /* C syntax */
```

In MATLAB, each function in an HDF5 interface is a method of a MATLAB class. The following shows the signature of the corresponding MATLAB function. First note that, because it's a method of a class, you must use the dot notation to call the MATLAB function: `H5F.open`. This MATLAB function accepts the same three arguments as the HDF5 function: a character vector containing the name, an HDF5-defined constant for the flags argument, and an HDF5 property list ID. You use property lists to specify characteristics of many different HDF5 objects. In this case, it's a file access property list. Refer to the HDF5 documentation to see which constants can be used with a particular function and note that, in MATLAB, constants are passed as character vectors.

```
file_id = H5F.open(name, flags, plist_id)
```

There are, however, some functions where the MATLAB function signature is different than the corresponding HDF5 library function. In general, keep the following differences in mind when using the MATLAB low-level HDF5 functions.

- **HDF5 output parameters become MATLAB return values** — Some HDF5 library functions use function parameters to return data. Because MATLAB functions can return multiple values, these output parameters become return values. To illustrate, the HDF5 `H5Dread` function returns data in the `buf` parameter.

```
herr_t H5Dread(hid_t dataset_id,
             hid_t mem_type_id,
             hid_t mem_space_id,
             hid_t file_space_id,
             hid_t xfer_plist_id,
             void * buf ) /* C syntax */
```

The corresponding MATLAB function changes the output parameter `buf` into a return value. Also, in the MATLAB function, the nonzero or negative value `herr_t` return values become MATLAB errors. Use MATLAB try-catch statements to handle errors.

```
buf = H5D.read(dataset_id,
             mem_type_id,
             mem_space_id,
             file_space_id,
             plist_id)
```

- **String length parameters are unnecessary** — The length parameter, used by some HDF5 library functions to specify the length of a string parameter, is not necessary in the corresponding MATLAB function. For example, the `H5Aget_name` function in the HDF5 library includes a buffer as an output parameter and the size of the buffer as an input parameter.

```
ssize_t H5Aget_name(hid_t attr_id,
                  size_t buf_size,
                  char *buf ) /* C syntax */
```

The corresponding MATLAB function changes the output parameter `buf` into a return value and drops the `buf_size` parameter.

```
buf = H5A.get_name(attr_id)
```

- **Use an empty array to specify NULL** — Wherever HDF5 library functions accept the value NULL, the corresponding MATLAB function uses empty arrays (`[]`). For example, the `H5Dfill` function in the HDF5 library accepts the value NULL in place of a specified fill value.

```
herr_t H5Dfill(const void *fill,
             hid_t fill_type_id, void *buf,
             hid_t buf_type_id,
             hid_t space_id ) /* C syntax */
```

When using the corresponding MATLAB function, you can specify an empty array (`[]`) instead of NULL.

- **Use cell arrays to specify multiple constants** — Some functions in the HDF5 library require you to specify an array of constants. For example, in the `H5Screate_simple` function, to specify that a dimension in the data space can be unlimited, you use the constant `H5S_UNLIMITED` for the dimension in `maxdims`. In MATLAB, because you pass constants as character vectors, you must use a cell array of character vectors to achieve the same result. The following code fragment provides an example of using a cell array of character vectors to specify this constant for each dimension of this data space.

```
ds_id = H5S.create_simple(2,[3 4],{'H5S_UNLIMITED' 'H5S_UNLIMITED'});
```

Map Between HDF5 Data Types and MATLAB Data Types

When the HDF5 low-level functions read data from an HDF5 file or write data to an HDF5 file, the functions map HDF5 data types to MATLAB data types automatically.

For *atomic* data types, such as commonly used binary formats for numbers (integers and floating point) and characters (ASCII), the mapping is typically straightforward because MATLAB supports similar types. See the table Map Between HDF5 Atomic Data Types and MATLAB Data Types for a list of these mappings.

Map Between HDF5 Atomic Data Types and MATLAB Data Types

HDF5 Atomic Data Type	MATLAB Data Type
Bit-field	Array of packed 8-bit integers
Float	MATLAB single and double types, provided that they occupy 64 bits or fewer
Integer types, signed and unsigned	Equivalent MATLAB integer types, signed and unsigned
Opaque	Array of uint8 values
Reference	Array of uint8 values
String	MATLAB string arrays

For *composite* data types, such as aggregations of one or more atomic data types into structures, multidimensional arrays, and variable-length data types (one-dimensional arrays), the mapping is sometimes ambiguous with reference to the HDF5 data type. In HDF5, a 5-by-5 data set containing a single uint8 value in each element is distinct from a 1-by-1 data set containing a 5-by-5 array of uint8 values. In the first case, the data set contains 25 observations of a single value. In the second case, the data set contains a single observation with 25 values. In MATLAB both of these data sets are represented by a 5-by-5 matrix.

If your data is a complex data set, you might need to create HDF5 data types directly to make sure that you have the mapping you intend. See the table Map Between HDF5 Composite Data Types and MATLAB Data Types for a list of the default mappings. You can specify the data type when you write data to the file using the `H5Dwrite` function. See the HDF5 data type interface documentation for more information.

Map Between HDF5 Composite Data Types and MATLAB Data Types

HDF5 Composite Data Type	MATLAB Data Type
Array	Extends the dimensionality of the data type which it contains. For example, an array of integers in HDF5 maps onto a two-dimensional array of integers in MATLAB.
Compound	MATLAB structure. Note: All structures representing HDF5 data in MATLAB are scalar.
Enumeration	Array of integers which each have an associated name
Variable Length	MATLAB 1-D cell arrays

Report Data Set Dimensions

The MATLAB low-level HDF5 functions report data set dimensions and the shape of data sets differently than the MATLAB high-level functions. For ease of use, the MATLAB high-level functions report data set dimensions consistent with MATLAB column-major indexing. To be consistent with the HDF5 library, and to support the possibility of nested data sets and complicated data types, the MATLAB low-level functions report array dimensions using the C row-major orientation.

Write Data to HDF5 Data Set Using MATLAB Low-Level Functions

This example shows how to use the MATLAB® HDF5 low-level functions to write a data set to an HDF5 file and then read the data set from the file.

Create a 2-by-3 array of data to write to an HDF5 file.

```
testdata = [1 3 5; 2 4 6];
```

Create a new HDF5 file named `my_file.h5` in the system temp folder. Use the MATLAB `H5F.create` function to create a file. This MATLAB function corresponds to the HDF5 function, `H5Fcreate`. As arguments, specify the name you want to assign to the file, the type of access you want to the file (`'H5F_ACC_TRUNC'` in this case), and optional additional characteristics specified by a file creation property list and a file access property list. In this case, use default values for these property lists (`'H5P_DEFAULT'`). Pass C constants to the MATLAB function as character vectors.

```
filename = fullfile(tempdir, 'my_file.h5');
fileID = H5F.create(filename, 'H5F_ACC_TRUNC', 'H5P_DEFAULT', 'H5P_DEFAULT');
```

`H5F.create` returns a file identifier corresponding to the HDF5 file.

Create the data set in the file to hold the MATLAB variable. In the HDF5 programming model, you must define the data type and dimensionality (data space) of the data set as separate entities. First, use the `H5T.copy` function to specify the data type used by the data set, in this case, `double`. This MATLAB function corresponds to the HDF5 function, `H5Tcopy`.

```
datatypeID = H5T.copy('H5T_NATIVE_DOUBLE');
```

`H5T.copy` returns a data type identifier.

Create a data space using `H5S.create_simple`, which corresponds to the HDF5 function, `H5Screate_simple`. The first input, 2, is the rank of the data space. The second input is an array specifying the size of each dimension of the dataset. Because HDF5 stores data in row-major order and the MATLAB array is organized in column-major order, you should reverse the ordering of the dimension extents before using `H5Screate_simple` to preserve the layout of the data. You can use `fliplr` for this purpose.

```
dims = size(testdata);
dataspaceID = H5S.create_simple(2, fliplr(dims), []);
```

`H5S.create_simple` returns a data space identifier, `dataspaceID`. Note that other software programs that use row-major ordering (such as `H5DUMP` from the HDF Group) might report the size of the dataset to be 3-by-2 instead of 2-by-3.

Create the data set using `H5D.create`, which corresponds to the HDF5 function, `H5Dcreate`. Specify the file identifier, the name you want to assign to the data set, the data type identifier, the data space identifier, and a data set creation property list identifier as arguments. `'H5P_DEFAULT'` specifies the default property list settings.

```
dsetname = 'my_dataset';
datasetID = H5D.create(fileID, dsetname, datatypeID, dataspaceID, 'H5P_DEFAULT');
```

`H5D.create` returns a data set identifier, `datasetID`.

Write the data to the data set using `H5D.write`, which corresponds to the HDF5 function, `H5Dwrite`. The input arguments are the data set identifier, the memory data type identifier, the memory space identifier, the data space identifier, the transfer property list identifier and the name of the MATLAB variable to write to the data set. The constant, `'H5ML_DEFAULT'`, specifies automatic mapping to HDF5 data types. The constant, `'H5S_ALL'`, tells `H5D.write` to write all the data to the file.

```
H5D.write(datasetID, 'H5ML_DEFAULT', 'H5S_ALL', 'H5S_ALL', ...
    'H5P_DEFAULT', testdata);
```

Close the data set, data space, data type, and file objects. If used inside a MATLAB function, these identifiers are closed automatically when they go out of scope.

```
H5D.close(datasetID);
H5S.close(dataspaceID);
H5T.close(datatypeID);
H5F.close(fileID);
```

Open the HDF5 file in order to read the data set you wrote. Use `H5F.open` to open the file for read-only access. This MATLAB function corresponds to the HDF5 function, `H5Fopen`.

```
fileID = H5F.open(filename, 'H5F_ACC_RDONLY', 'H5P_DEFAULT');
```

Open the data set to read using `H5D.open`, which corresponds to the HDF5 function, `H5Dopen`. Specify as arguments the file identifier and the name of the data set, defined earlier in the example.

```
datasetID = H5D.open(fileID, dsetname);
```

Read the data into the MATLAB workspace using `H5D.read`, which corresponds to the HDF5 function, `H5Dread`. The input arguments are the data set identifier, the memory data type identifier, the memory space identifier, the data space identifier, and the transfer property list identifier.

```
returned_data = H5D.read(datasetID, 'H5ML_DEFAULT', ...
    'H5S_ALL', 'H5S_ALL', 'H5P_DEFAULT');
```

Compare the original MATLAB variable, `testdata`, with the variable just created, `returned_data`.

```
isequal(testdata, returned_data)
```

```
ans = logical
     1
```

The two variables are the same.

Write Large Data Set

To write a large data set, you must use the chunking capability of the HDF5 library. Create a property list and use the `H5P.set_chunk` function to set the chunk size in the property list. Suppose the dimensions of your data set are $[2^{16} \ 2^{16}]$ and the chunk size is 1024-by-1024. You then pass the property list as the last argument to the data set creation function, `H5D.create`, instead of using the `H5P_DEFAULT` value.

```
dims = [2^16 2^16];
plistID = H5P.create('H5P_DATASET_CREATE'); % create property list

chunk_size = min([1024 1024], dims); % define chunk size
H5P.set_chunk(plistID, flip1r(chunk_size)); % set chunk size in property list

datasetID = H5D.create(fileID, dsetname, datatypeID, dataspaceID, plistID);
```

Preserve Correct Layout of Your Data

When you use any of the following functions that deal with dataspace, you should flip dimension extents to preserve the correct layout of the data.

- `H5D.set_extent`

- `H5P.get_chunk`
- `H5P.set_chunk`
- `H5S.create_simple`
- `H5S.get_simple_extent_dims`
- `H5S.select_hyperslab`
- `H5T.array_create`
- `H5T.get_array_dims`

Write HDF5 Data Set Using Dynamically Loaded Filters

MATLAB supports reading and writing HDF5 data sets using dynamically loaded filters. The HDF Group maintains a list of registered filters at [Filters on The HDF Group website](#).

To write a data set using a third-party filter, follow these steps:

- 1 Install the HDF5 filter plugin on your system as a shared library or DLL.
- 2 Obtain the unique filter identifier for the filter plugin assigned by The HDF Group from the list of registered filters.
- 3 Set the `HDF5_PLUGIN_PATH` environment variable to the folder containing the installed plugin binary file. On a Windows system, use the `setenv` command in MATLAB. On a Linux or Mac system, perform this action in a terminal window before you start MATLAB.

After you complete these steps, you can use the high-level or low-level MATLAB HDF5 functions to create and write data sets using the third-party filter specified by its unique filter identifier. For more information, see [HDF5 Dynamically Loaded Filters](#).

Linux Users Only: Rebuild Filter Plugins Using MATLAB HDF5 Shared Library

Starting in R2021b, in certain cases, Linux users using a filter plugin with callbacks to core HDF5 library functions must rebuild the plugin using the shipping MATLAB HDF5 shared library, `/matlab/bin/glnxa64/libhdf5.so.x.x.x`. If you do not rebuild the plugin using this version of the shared library, you might experience issues ranging from undefined behavior to crashes. For more information, see [Build HDF5 Filter Plugins on Linux Using MATLAB HDF5 Shared Library or GNU Export Map](#).

See Also

Related Examples

- “Import HDF5 Files” on page 7-28

Work with Non-ASCII Characters in HDF5 Files

To enable sharing of HDF5 files across multiple locales, MATLAB supports the use of non-ASCII characters in HDF5 files. This example shows you how to:

- Create HDF5 files containing data set and attribute names that have non-ASCII characters using the high-level functions.
- Create variable-length string data sets containing non-ASCII characters using the low-level functions.

Create Data Set and Attribute Names Containing Non-ASCII Characters

Create an HDF5 file containing a data set name and an attribute name that contains non-ASCII characters. To check if the data set and attribute names appear as expected, write data to the data set, and display the file information.

Create a data set with a name (/数据集) that includes non-ASCII characters.

```
dsetName = ['/ ' char([25968 25454 38598])];
dsetDims = [5 2];
h5create('outfile.h5',['/grp1' dsetName],dsetDims,...
        'TextEncoding','UTF-8');
```

Write data to the file.

```
dataToWrite = rand(dsetDims);
h5write('outfile.h5',['/grp1' dsetName],dataToWrite);
```

Create an attribute name (屬性名稱) that includes non-ASCII characters and assign a value to the attribute.

```
attrName = char([25967 25453 38597]);
h5writeatt('outfile.h5','/',attrName,'I am an attribute',...
        'TextEncoding','UTF-8');
```

Display information about the file and check if the attribute name and data set name appear correctly.

```
h5disp('outfile.h5')

HDF5 outfile.h5
Group '/'
  Attributes:
    '/屬性名稱': 'I am an attribute'
  Group '/grp1'
    Dataset '数据集'
      Size: 5x2
      MaxSize: 5x2
      Datatype: H5T_IEEE_F64LE (double)
      ChunkSize: []
      Filters: none
      FillValue: 0.000000
```

Create Variable-Length String Data Containing Non-ASCII Characters

Create a variable-length string data set to store data containing non-ASCII characters using the low-level functions. Write the data to the data set. Check if the data is written correctly.

Create data containing non-ASCII characters.

```
dataToWrite = {char([12487 12540 12479]) 'hello' ...
               char([1605 1585 1581 1576 1575]); ...
               'world' char([1052 1080 1088]) ...
               char([954 972 963 956 959 962])};
disp(dataToWrite)
```

```
'データ'   'hello'   'مرحبا'
'world'    'Мир'    'κόσμος'
```

To write this data into a file, create an HDF5 file, define a group name, and a data set name within the group.

Create the HDF5 file.

```
fileName = 'outfile.h5';
fileID = H5F.create(fileName, 'H5F_ACC_TRUNC', ...
                   'H5P_DEFAULT', 'H5P_DEFAULT');
```

To create the group containing non-ASCII characters in its name, first, configure the link creation property.

```
lcplID = H5P.create('H5P_LINK_CREATE');
H5P.set_char_encoding(lcplID, H5ML.get_constant_value('H5T_CSET_UTF8'));
plist = 'H5P_DEFAULT';
```

Then, create the group (グループ).

```
grpName = char([12464 12523 12540 12503]);
grpID = H5G.create(fileID, grpName, lcplID, plist, plist);
```

Create a data set that contains variable-length string data with non-ASCII characters. First, configure its data type.

```
typeID = H5T.copy('H5T_C_S1');
H5T.set_size(typeID, 'H5T_VARIABLE');
H5T.set_cset(typeID, H5ML.get_constant_value('H5T_CSET_UTF8'));
```

Now create the data set by specifying its name, data type, and dimensions.

```
dsetName = 'datasetUtf8';
dataDims = [2 3];
h5DataDims = fliplr(dataDims);
h5MaxDims = h5DataDims;
spaceID = H5S.create_simple(2, h5DataDims, h5MaxDims);
dsetID = H5D.create(grpID, dsetName, typeID, spaceID, ...
                  'H5P_DEFAULT', 'H5P_DEFAULT', 'H5P_DEFAULT');
```

Write the data to the data set.

```
H5D.write(dsetID, 'H5ML_DEFAULT', 'H5S_ALL', ...
          'H5S_ALL', 'H5P_DEFAULT', dataToWrite);
```

Read the data back.

```
dataRead = h5read('outfile.h5',['/' grpName '/' dsetName])
```

```
dataRead =
```

```
2x3 cell array
```

```
 {'データ'}    {'hello'}    {'مرحبا' }  
 {'world'}    {'Мир' }    {'κόσμος' }
```

Check if data in the file matches the written data.

```
isequal(dataRead,dataToWrite)
```

```
ans =
```

```
logical
```

```
1
```

Close ids.

```
H5D.close(dsetID);  
H5S.close(spaceID);  
H5T.close(typeID);  
H5G.close(grpID);  
H5P.close(lcplID);  
H5F.close(fileID);
```

See Also

[h5create](#) | [h5writeatt](#) | [h5info](#) | [h5disp](#)

Import HDF4 Files Programmatically

In this section...

“Overview” on page 7-44

“Using the MATLAB HDF4 High-Level Functions” on page 7-44

Overview

Hierarchical Data Format (HDF4) is a general-purpose, machine-independent standard for storing scientific data in files, developed by the National Center for Supercomputing Applications (NCSA). For more information about these file formats, read the HDF documentation at the HDF Web site (www.hdfgroup.org).

HDF-EOS is an extension of HDF4 that was developed by the National Aeronautics and Space Administration (NASA) for storage of data returned from the Earth Observing System (EOS). For more information about this extension to HDF4, see the HDF-EOS documentation at the NASA Web site (www.hdfeos.org).

MATLAB includes several options for importing HDF4 files, discussed in the following sections.

Note For information about importing HDF5 data, which is a separate, incompatible format, see “Import HDF5 Files” on page 7-28.

Using the MATLAB HDF4 High-Level Functions

To import data from an HDF or HDF-EOS file, you can use the MATLAB HDF4 high-level function `hdfread`. The `hdfread` function provides a programmatic way to import data from an HDF4 or HDF-EOS file that still hides many of the details that you need to know if you use the low-level HDF functions, described in “Import HDF4 Files Using Low-Level Functions” on page 7-65.

This section describes these high-level MATLAB HDF functions, including

- “Using `hdfinfo` to Get Information About an HDF4 File” on page 7-44
- “Using `hdfread` to Import Data from an HDF4 File” on page 7-45

To export data to an HDF4 file, you must use the MATLAB HDF4 low-level functions.

Using `hdfinfo` to Get Information About an HDF4 File

To get information about the contents of an HDF4 file, use the `hdfinfo` function. The `hdfinfo` function returns a structure that contains information about the file and the data in the file.

This example returns information about a sample HDF4 file included with MATLAB:

```
info = hdfinfo('example.hdf')
info =
    Filename: 'matlabroot\example.hdf'
    Attributes: [1x2 struct]
    Vgroup: [1x1 struct]
```

```
SDS: [1x1 struct]
Vdata: [1x1 struct]
```

To get information about the data sets stored in the file, look at the `SDS` field.

Using `hdfread` to Import Data from an HDF4 File

To use the `hdfread` function, you must specify the data set that you want to read. You can specify the filename and the data set name as arguments, or you can specify a structure returned by the `hdfinfo` function that contains this information. The following example shows both methods. For information about how to import a subset of the data in a data set, see “Reading a Subset of the Data in a Data Set” on page 7-46.

- 1 Determine the names of data sets in the HDF4 file, using the `hdfinfo` function.

```
info = hdfinfo('example.hdf')

info =

    Filename: 'matlabroot\example.hdf'
    Attributes: [1x2 struct]
    Vgroup: [1x1 struct]
    SDS: [1x1 struct]
    Vdata: [1x1 struct]
```

To determine the names and other information about the data sets in the file, look at the contents of the `SDS` field. The `Name` field in the `SDS` structure gives the name of the data set.

```
dsets = info.SDS

dsets =

    Filename: 'example.hdf'
    Type: 'Scientific Data Set'
    Name: 'Example SDS'
    Rank: 2
    DataType: 'int16'
    Attributes: []
    Dims: [2x1 struct]
    Label: {}
    Description: {}
    Index: 0
```

- 2 Read the data set from the HDF4 file, using the `hdfread` function. Specify the name of the data set as a parameter to the function. Note that the data set name is case sensitive. This example returns a 16-by-5 array:

```
dset = hdfread('example.hdf', 'Example SDS')

dset =

     3     4     5     6     7
     4     5     6     7     8
     5     6     7     8     9
     6     7     8     9    10
     7     8     9    10    11
     8     9    10    11    12
     9    10    11    12    13
    10    11    12    13    14
```

```
11    12    13    14    15
12    13    14    15    16
13    14    15    16    17
14    15    16    17    18
15    16    17    18    19
16    17    18    19    20
17    18    19    20    21
18    19    20    21    22
```

Alternatively, you can specify the specific field in the structure returned by `hdfinfo` that contains this information. For example, to read a scientific data set, use the `SDS` field.

```
dset = hdfread(info.SDS);
```

Reading a Subset of the Data in a Data Set

To read a subset of a data set, you can use the optional `'index'` parameter. The value of the `index` parameter is a cell array of three vectors that specify the location in the data set to start reading, the skip interval (e.g., read every other data item), and the amount of data to read (e.g., the length along each dimension). In HDF4 terminology, these parameters are called the *start*, *stride*, and *edge* values.

For example, this code

- Starts reading data at the third row, third column (`[3 3]`).
- Reads every element in the array (`[]`).
- Reads 10 rows and 2 columns (`[10 2]`).

```
subset = hdfread('Example.hdf','Example SDS',...
                'Index',{[3 3],[1],[10 2 1]})
```

```
subset =
```

```
7     8
8     9
9    10
10    11
11    12
12    13
13    14
14    15
15    16
16    17
```

Read and Write Data Concurrently Using Single-Writer/Multiple-Reader (SWMR)

Overview

The Single-Writer/Multiple-Reader (SWMR) feature of the MATLAB low-level HDF5 function interface allows you to append data to datasets or overwrite existing data while several reader processes concurrently read the new data from the file. The reader and writer processes can run on the same platform or different platforms, and no communication between the processes or file locking is needed.

To use SWMR, you must be familiar with the HDF5 SWMR programming model. For more information, see the HDF5 SWMR Documentation on The HDF Group website.

Note MATLAB releases earlier than R2021b might not be able to read HDF5 files or objects created using R2021b or later releases due to the file format changes in HDF5 version 1.10. HDF5 files created with SWMR access are not compatible with versions of HDF5 prior to 1.10. Because the HDF5 library is always backward compatible, MATLAB R2021b and later releases can read and modify HDF5 files or objects created using any MATLAB release.

Requirements and Limitations

- An HDF5 file with SWMR access must be located on a file system that complies with the Portable Operating System Interface (POSIX) write() semantics, and the writer and reader processes must follow the SWMR programming model.
- SWMR is not supported on remote file locations.
- You must follow the SWMR implementation scope:
 - 1** The writer process is allowed to modify raw data of existing datasets only by:
 - Appending data along an unlimited dimension
 - Modifying existing data
 - 2** The writer process is not allowed to:
 - Add new objects to or delete objects from the file. Such objects include groups, datasets, links, committed datatypes, and attributes.
 - Modify or append to any data items containing variable-size data types (including string data types).
 - 3** File space recycling is not allowed. The size of a file modified by a SWMR writer may be greater than if a non-SWMR writer had modified the file.

For more information on SWMR requirements and limitations, see the HDF5 SWMR User's Guide on The HDF Group website.

Enable SWMR Access for HDF5 File

Follow these general steps in MATLAB to enable SWMR access in on HDF5 file:

- 1 Create the file with the latest file format by specifying the lower and upper bounds of the library version as 'H5F_LIBVER_LATEST' in the call to the `H5P.set_libver_bounds` function.

```
H5P.set_libver_bounds(faplID, 'H5F_LIBVER_LATEST', 'H5F_LIBVER_LATEST');
```

- 2 Enable SWMR write access for the HDF5 file and flush the dataset after each write operation.

- a Specify the flag 'H5F_ACC_SWMR_WRITE' in the call to the `H5F.open` function. For example, open the file with SWMR write access using the default property list settings.

```
fileID = H5F.open(myFile, 'H5F_ACC_RDWR|H5F_ACC_SWMR_WRITE', 'H5P_DEFAULT');
```

Alternatively, you can enable SWMR write access using the `H5F.start_swmr_write` function.

- b Flush the dataset after each write operation using `H5D.flush`.

- 3 Enable SWMR read access for the HDF5 file and refresh the dataset before each read operation.

- a Open the file for SWMR read access by specifying the flag 'H5F_ACC_SWMR_READ' in the call to the `H5F.open` function. For example, open the file with SWMR read access using the default property list settings.

```
fileID = H5F.open(myFile, 'H5F_ACC_RDONLY|H5F_ACC_SWMR_READ', 'H5P_DEFAULT');
```

- b Refresh the dataset before each read operation using `H5D.refresh`.

Write to HDF5 File While Two Processes Read

Use SWMR to write surface data to an HDF5 file, while one reader process records peak data in a text file and another plots the surface data over time. This example uses data generated from the MATLAB `peaks` function.

This example defines three functions, `writeData`, `readPlot3D`, and `readLogger`, which can be run concurrently in an SWMR-enabled environment. You must run `writeData` before `readPlot3D` and `readLogger` to create the HDF5 file if it does not exist.

Create a writer function named `writeData` that writes a 2-D array of data to an HDF5 file.

When you create the file, set the lower and upper library version bounds to 'H5F_LIBVER_LATEST' in the call to the `H5P.set_libver_bounds` function. Then, enable SWMR write access to the file by specifying the flag 'H5F_ACC_SWMR_WRITE' in the call to the `H5F.open` function.

Finally, flush the dataset after each write operation using `H5D.flush`.

```
function writeData(dataFile)
    % Create HDF5 file if does not already exist, and initialize dataset.
    if ~exist(dataFile, 'file')
        % Create file access property list, set library version flags, and create the file.
        faplID = H5P.create('H5P_FILE_ACCESS');
        H5P.set_libver_bounds(faplID, 'H5F_LIBVER_LATEST', 'H5F_LIBVER_LATEST');
        fileID = H5F.create(dataFile, 'H5F_ACC_TRUNC', 'H5P_DEFAULT', faplID);

        % Create and write dataset.
        datatypeID = H5T.copy('H5T_NATIVE_DOUBLE');
        dataspaceID = H5S.create_simple(2, [25 25], []);
        datasetID = H5D.create(fileID, '/peaks', datatypeID, dataspaceID, 'H5P_DEFAULT');
        H5D.write(datasetID, 'H5ML_DEFAULT', 'H5S_ALL', 'H5S_ALL', 'H5P_DEFAULT', NaN(25));
```



```

    % Close open resources.
    H5D.close(datasetID);
    H5S.close(dataspaceID);
    H5T.close(datatypeID);
    H5F.close(fileID);
end

% Open HDF5 file with support for SWMR write access and open dataset.
fileID = H5F.open(dataFile, 'H5F_ACC_RDWR|H5F_ACC_SWMR_WRITE', 'H5P_DEFAULT');
datasetID = H5D.open(fileID, '/peaks');

% Loop through writing Z data to file.
for t = 0 : 0.05 : 15
    Z = exp(-0.15*t) * sin(10*t) * abs(peaks(25));
    H5D.write(datasetID, 'H5ML_DEFAULT', 'H5S_ALL', 'H5S_ALL', 'H5P_DEFAULT', Z);

    % Flush data in the dataset after writing.
    H5D.flush(datasetID);
    pause(0.05);
end

% Close open resources.
H5D.close(datasetID);
H5F.close(fileID);

```

end

Create a reader function named `readPlot3D` that plots data stored in the `/peaks` dataset of the input HDF5 file.

Enable SWMR read access by specifying the flag `'H5F_ACC_SWMR_READ'` in the call to the `H5F.open` function. Refresh the data in the dataset before each subsequent read.

```

function readPlot3D(dataFile)
    % Open HDF5 file with for SWMR read access and open dataset.
    h5FileID = H5F.open(dataFile, 'H5F_ACC_RDONLY|H5F_ACC_SWMR_READ', 'H5P_DEFAULT');
    datasetID = H5D.open(h5FileID, '/peaks');

    % Loop through reading Z data from file and 3D plotting it.
    hSurf = [];
    for t = 0 : 0.05 : 15
        % Refresh dataset before reading.
        H5D.refresh(datasetID);
        Z = H5D.read(datasetID, 'H5ML_DEFAULT', 'H5S_ALL', 'H5S_ALL', 'H5P_DEFAULT');
        if isempty(hSurf)
            % Create surface plot if not present.
            hSurf = surf(Z);
            zlim([-8 8]);
            caxis([-5 5]);
        else
            % Update surface plot Z data otherwise.
            hSurf.ZData = Z;
        end
        pause(0.05);
    end

    % Close open resources

```

```

H5D.close(datasetID);
H5F.close(h5FileID);
end

```

The `readPlot3D` function updates the plot with each iteration, resulting in a surface plot similar to the following one.

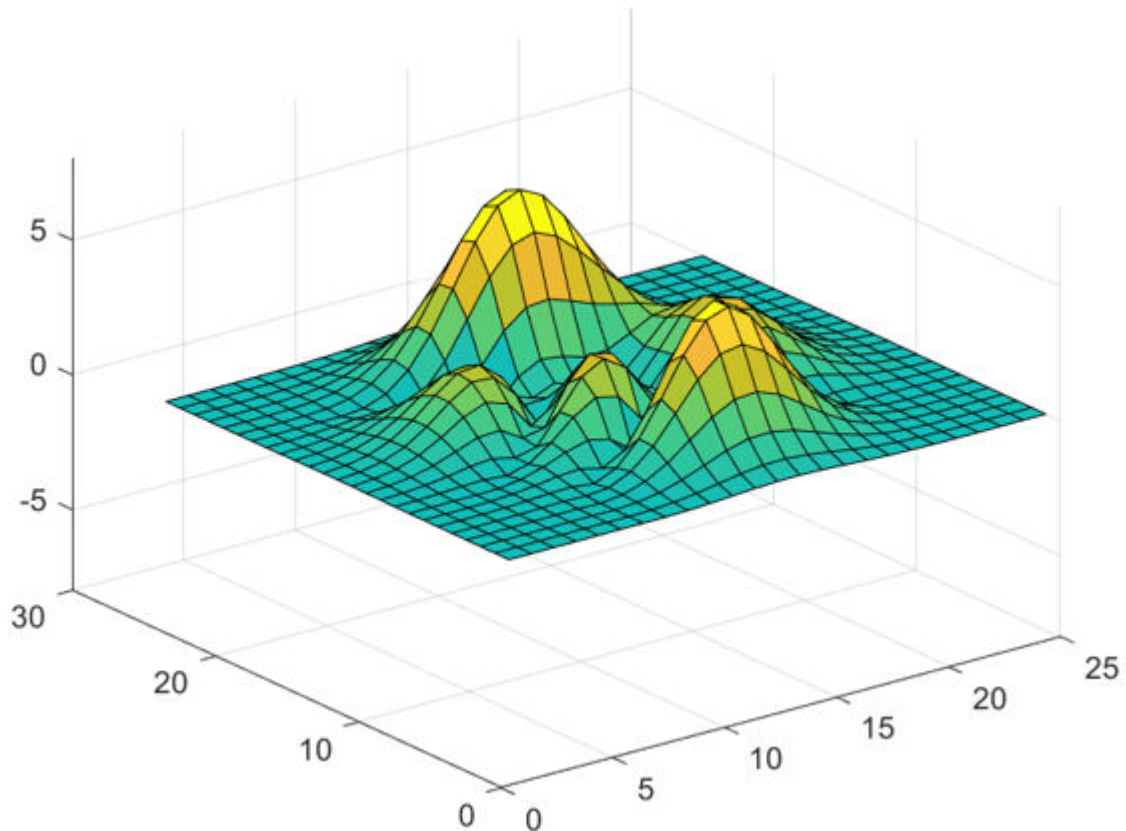

Create a second reader function named `readLogger` that reads the data in the `/peaks` dataset and logs the data taken at one sampling point.

Enable SWMR read access by specifying the flag `'H5F_ACC_SWMR_READ'` in the call to the `H5F.open` function. Refresh the data in the dataset before each subsequent read.

```

function readLogger(dataFile)
    % Open HDF5 file with SWMR read access and open dataset.
    h5FileID = H5F.open(dataFile, 'H5F_ACC_RDONLY|H5F_ACC_SWMR_READ', 'H5P_DEFAULT');
    datasetID = H5D.open(h5FileID, '/peaks');

    % Open log file for saving records.
    recordFileID = fopen('logs.txt', 'w');
    fprintf(recordFileID, 't,Zpeak\n');

    % Loop through reading Z data from the file and recording central value.
    for t = 0 : 0.05 : 15
        % Refresh dataset before reading.
        H5D.refresh(datasetID);
        Z = H5D.read(datasetID, 'H5ML_DEFAULT', 'H5S_ALL', 'H5S_ALL', 'H5P_DEFAULT');
    end
end

```

```
    idx = round(size(Z,1)/2);  
    fprintf(recordFileID, '%.3f,%.3f\n', t, Z(idx,idx));  
    pause(0.05);  
end  
  
% Close open resources.  
H5D.close(datasetID);  
H5F.close(h5FileID);  
fclose(recordFileID);  
end
```

The `readLogger` function writes data samples to a text file named `logs.txt`. You can plot the data in `logs.txt` to obtain the following figure.

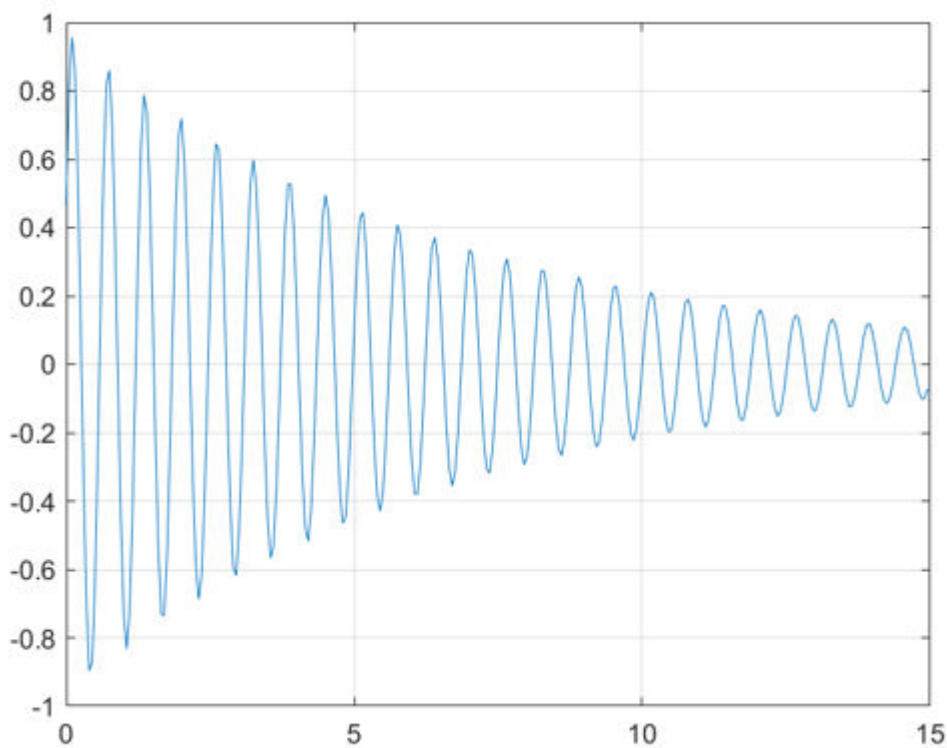

See Also

“Work with HDF5 Virtual Datasets (VDS)” on page 7-52 | Property (H5P) | Dataset (H5D) | File (H5F)

Work with HDF5 Virtual Datasets (VDS)

Overview

The HDF5 Virtual Dataset (VDS) feature allows you to access data from a collection of HDF5 files as a single, unified dataset, without modifying how the data is stored in the original files. Virtual datasets can have unlimited dimensions and map to source datasets with unlimited dimensions. This mapping allows a Virtual Dataset to grow over time, as its underlying source datasets change in size.

The VDS feature was introduced in the HDF5 library version 1.10. To use VDS, you must be familiar with the HDF5 VDS programming model. For more information, see the HDF5 Virtual Dataset documentation on The HDF Group website.

Note MATLAB versions earlier than R2021b cannot read HDF5 Virtual Datasets.

Create a Virtual Dataset

Follow these general steps for building a Virtual Dataset:

- 1 Create datasets that comprise the VDS (the source datasets) (optional).
- 2 Create the VDS.
 - a Define a datatype.
 - b Define a dataspace.
 - c Define the dataset creation property list.
 - d Map elements from the source datasets to the elements of the VDS.
 - i Iterate over the source datasets.
 - A Select elements in the source dataset (source selection).
 - B Select elements in the Virtual Dataset (destination selection).
 - C Map destination selections to source selections using a dataset creation property list call.
 - ii End the iteration.
 - e Call `H5D.create` using the defined properties.
- 3 Access the VDS as a regular HDF5 dataset.
- 4 Close the VDS when finished.

Note The HDF5 C library uses C-style ordering for multidimensional arrays, whereas MATLAB uses FORTRAN-style ordering. For more information, see “Report Data Set Dimensions” on page 7-37.

Work with Remotely Stored Virtual Datasets

You can use the MATLAB low-level HDF5 functions to create and read Virtual Datasets stored in remote locations, such as Amazon S3™ and Windows Azure® Blob Service. Use the high-level HDF5 functions to read and access information on Virtual Datasets stored in remote locations.

When accessing a Virtual Dataset stored in a remote location, you must specify the full path using a uniform resource locator (URL). For example, display the metadata of an HDF5 file stored on Amazon S3.

```
h5disp('s3://bucketname/path_to_file/my_VDSdata.h5');
```

For more information on setting up MATLAB to access your online storage service, see “Work with Remote Data” on page 13-93.

Create Virtual Dataset from Datasets of Varying Sizes

Create an HDF5 Virtual Dataset from datasets of varying sizes and with mismatching group and dataset names. The elevation data in the three datasets is generated from the MATLAB `peaks` function.

Use three datasets containing elevation data to reconstruct a larger, more complete topographical map. The three datasets are disjoint, meaning spatial data is missing along one or more of their shared dimensions, and they vary in shape and size.

Reconstruct the topographical profile with the three disjoint datasets. The sampling points from the three datasets are overlaid on the topographical profile according to their geospatial coordinates. In both plots, the x and y axes represent longitudes and latitudes, respectively, with latitudes increasing in the y-direction.

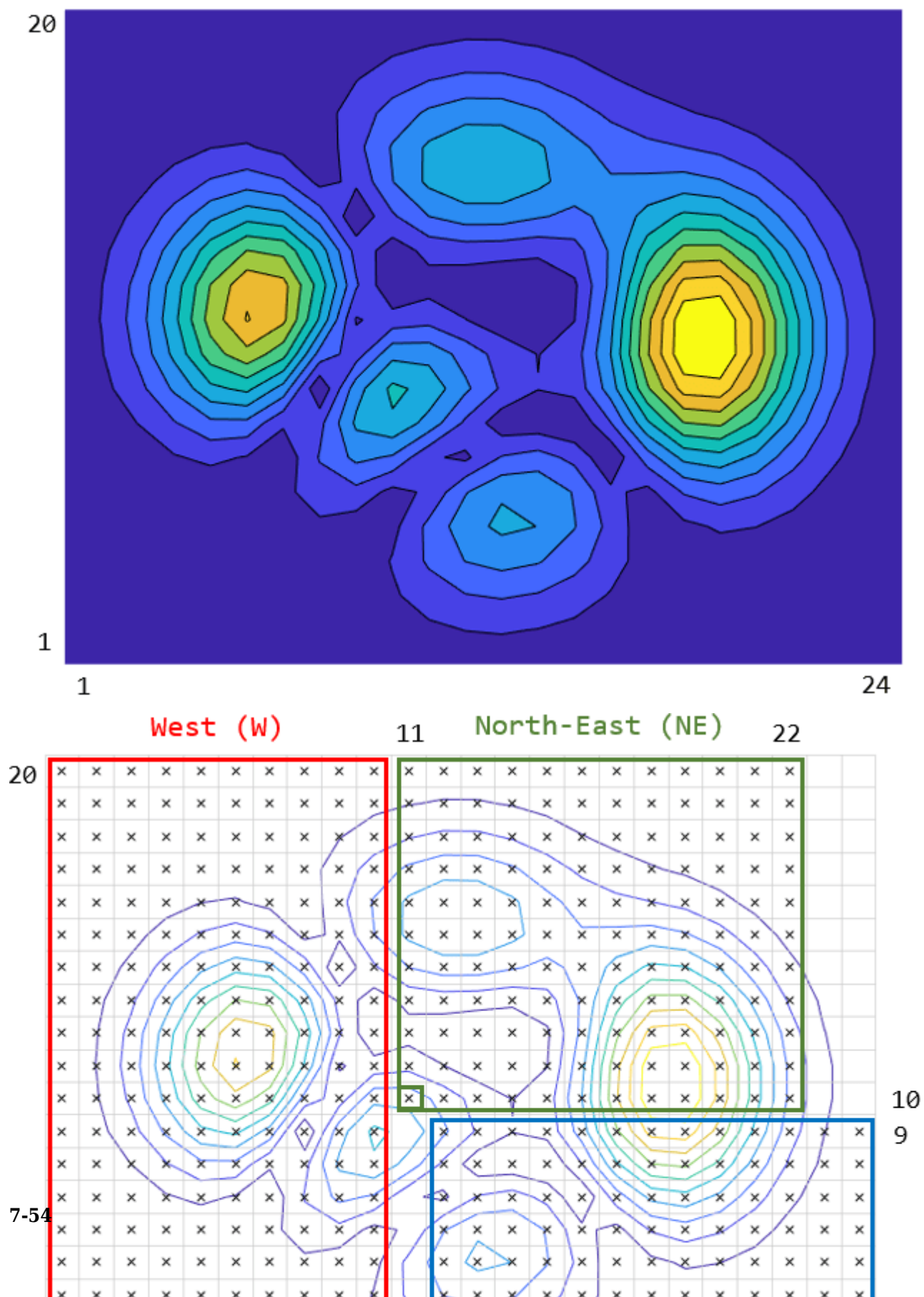

Display information on the three datasets in the files `data_W.h5`, `data_NE.h5`, `data_SE.h5`. The `h5disp` function displays information about the datasets, including their names, datatypes, dimensions, and groups to which they belong.

```
h5disp("data_W.h5")
```

```
HDF5 data_W.h5
Group '/'
  Group '/data'
    Dataset 'elevation'
      Size: 20x10
      MaxSize: 20x10
      Datatype: H5T_IEEE_F64LE (double)
      ChunkSize: []
      Filters: none
      FillValue: 0.000000
```

```
h5disp("data_NE.h5")
```

```
HDF5 data_NE.h5
Group '/'
  Dataset 'z'
    Size: 11x12
    MaxSize: 11x12
    Datatype: H5T_IEEE_F64LE (double)
    ChunkSize: []
    Filters: none
    FillValue: 0.000000
```

```
h5disp("data_SE.h5")
```

```
HDF5 data_SE.h5
Group '/'
  Dataset 'Elev'
    Size: 9x13
    MaxSize: 9x13
    Datatype: H5T_IEEE_F64LE (double)
    ChunkSize: []
    Filters: none
    FillValue: 0.000000
```

Create a dataspace and creation property list for the Virtual Dataset. Then, map each dataset to the virtual dataspace using C-style dimensions ordering and zero-based indexing.

For instance, the lower-left corner of the data block for the North-East region corresponds to MATLAB indices `[10 11]`. To convert these indices to C-style ordered, zero-based indices, flip the indices `[10 11]` and subtract the value 1. The resulting start indices are `[10 9]`.

```
% Define the fill value and specify the file access property list identifier.
```

```
fillValue = NaN;
faplID = H5P.create('H5P_FILE_ACCESS');
```

```
% Create the file for the Virtual Dataset.
```

```
vdsFileID = H5F.create('data_VDS.h5', 'H5F_ACC_TRUNC', 'H5P_DEFAULT', faplID);
```

```
% Define the datatype and dataspace.
```

```
datatypeID = H5T.copy('H5T_NATIVE_DOUBLE');
vdsDataspaceID = H5S.create_simple(2, [24 20], []);
```

```

% Initialize Virtual Dataset creation property list with virtual layout and fill value.
vdsDcplID = H5P.create('H5P_DATASET_CREATE');
H5P.set_layout(vdsDcplID, 'H5D_VIRTUAL');
H5P.set_fill_value(vdsDcplID, datatypeID, fillValue);

% Perform full dataset mapping for three individual source datasets.

% Map '/data/elevation' from data_W.h5 to the Virtual Dataset.
srcDataspaceID_W = H5S.create_simple(2, [10 20], []);
H5S.select_hyperslab(vdsDataspaceID, 'H5S_SELECT_SET', [0 0], [], [], [10 20]);
H5P.set_virtual(vdsDcplID, vdsDataspaceID, 'data_W.h5', '/data/elevation', srcDataspaceID_W);

% Map '/z' from data_NE.h5 to the Virtual Dataset.
srcDataspaceID_NE = H5S.create_simple(2, [12 11], []);
H5S.select_hyperslab(vdsDataspaceID, 'H5S_SELECT_SET', [10 9], [], [], [12 11]);
H5P.set_virtual(vdsDcplID, vdsDataspaceID, 'data_NE.h5', '/z', srcDataspaceID_NE);

% Map '/Elev' from data_SE.h5 to the Virtual Dataset.
srcDataspaceID_SE = H5S.create_simple(2, [13 9], []);
H5S.select_hyperslab(vdsDataspaceID, 'H5S_SELECT_SET', [11 0], [], [], [13 9]);
H5P.set_virtual(vdsDcplID, vdsDataspaceID, 'data_SE.h5', '/Elev', srcDataspaceID_SE);

Create the HDF5 file and the Virtual Dataset /elevation, and then close all open resources.

% Call H5D.create using the defined properties.
vdsDatasetID = H5D.create(vdsFileID, '/elevation', datatypeID, vdsDataspaceID, 'H5P_DEFAULT', vdsDcplID);

% Close open resources.
H5D.close(vdsDatasetID);
H5S.close(srcDataspaceID_SE);
H5S.close(srcDataspaceID_NE);
H5S.close(srcDataspaceID_W);
H5P.close(vdsDcplID);
H5S.close(vdsDataspaceID);
H5T.close(datatypeID);
H5F.close(vdsFileID);
H5P.close(faplID);

Read the Virtual Dataset and plot it.

The resulting plot is similar to the original plot of the topographical map, except for the areas where
data is missing due to the disjoint datasets.

% Read elevations using the low-level interface.
vdsFileID = H5F.open('data_VDS.h5', 'H5F_ACC_RDONLY', 'H5P_DEFAULT');
vdsDatasetID = H5D.open(vdsFileID, '/elevation', 'H5P_DEFAULT');
elevation = H5D.read(vdsDatasetID, 'H5ML_DEFAULT', 'H5S_ALL', 'H5S_ALL', 'H5P_DEFAULT');
H5D.close(vdsDatasetID);
H5F.close(vdsFileID);
contourf(elevation, 10);

```

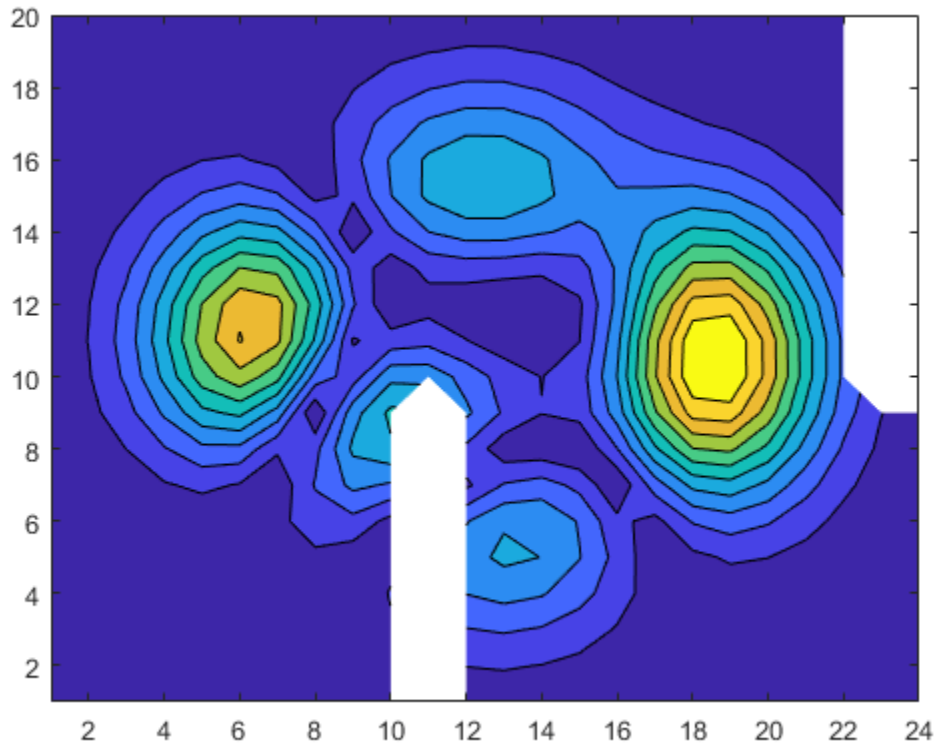
Display the contents of the Virtual Dataset file.

```
h5disp('data_VDS.h5')
```

```
HDF5 data_VDS.h5
Group '/'
  Dataset 'elevation'
    Size: 20x24
    MaxSize: 20x24
    Datatype: H5T_IEEE_F64LE (double)
    ChunkSize: []
    Filters: none
    FillValue: NaN
```

You can perform I/O operations on the Virtual Dataset. For instance, read a hyperslab of data from the `/elevation` dataset using the `h5read` function in the high-level interface.

```
sample = h5read('data_VDS.h5', '/elevation', [1 1], [5 6], [4 4])
```

```
sample = 5x6
```

```
0.0007    0.0102    0.0823    0.3265    0.0765    0.0059
0.0028    0.0331    0.3023    2.9849    0.1901    0.4741
0.1661    3.3570    2.5482    1.3171    4.8474    3.3676
0.1915    3.9606    1.1585    0.9892    3.9113    2.5722
0.0151    0.2633    1.0373    2.5380    0.9625    0.2401
```

See Also

“Read and Write Data Concurrently Using Single-Writer/Multiple-Reader (SWMR)” on page 7-47 |
Property (H5P) | Dataspace (H5S)

Read and Write HDF5 Datasets Using Dynamically Loaded Filters

The HDF5 library and file format enables using filters on data chunks before they are written to or after they are read from disk. Compression filters, for example, can substantially reduce the size of the data to be stored on disk and improve the overall performance of reading from and writing to an HDF5 dataset.

The HDF5 library includes a small set of internal filters, and MATLAB supports most of them. While these filters work relatively well, they may not always provide an optimal performance improvement. For this reason, the HDF5 library and MATLAB support dynamically loaded filters, a mechanism that enables loading third-party filters at run time and adding them to the filter pipeline. To use dynamically-loaded filters, install filter plugins for reading datasets that were created using third-party filters, or for creating and writing datasets using third-party filters.

Both MATLAB high- and low-level interfaces support workflows that involve dynamically loaded filters. You can read HDF5 datasets encoded using third-party filters through typical workflows as long as the necessary filter plugins are available on your system.

- High-level interface — `h5create` supports two name-value arguments for specifying the filter identifier and parameters when creating datasets.
- Low-level interface — The low-level interface enables more advanced filter workflows, including `H5P.set_filter` for adding filters to the filter pipeline and `H5Z.filter_avail` for checking if a filter is available. To take full advantage of the low-level interface, you must be familiar with the HDF5 C API. For more information, see the documentation on the HDF5 Group website about Dynamically Loaded Filters.

Install Filter Plugins

MATLAB supports three internal HDF5 filters: Deflate (GZIP), Shuffle, and Fletcher32. To read or write datasets using third-party filters, install and configure filter plugins.

- 1 Install the relevant filter plugins:
 - On Windows and Mac — Download and install the plugin binaries for your operating system from The HDF Group.

Install the bundle of filter plugins for the version of HDF5 shipped with your MATLAB release. To query the version of HDF5 in your MATLAB release, use `H5.get_libversion`.
 - On Linux — Get the filter plugin source code and build it against the version of HDF5 that is shipped with MATLAB. To obtain the filter plugin source code, see [The HDF Group - Filters](#). Alternatively, you can build HDF5 from source using the instructions and the export map file from [Build HDF5 Filter Plugins on MATLAB Answers™](#), and then build the filter plugin against your built HDF5 library.
- 2 Set the `HDF5_PLUGIN_PATH` environment variable to point to the local installation of the plugins:
 - On Windows — Set the environment variable using *System Properties > Advanced > Environment Variables*.
 - On Linux and Mac — Set the environment variable from the terminal before starting MATLAB.
- 3 Restart MATLAB.

Read Datasets Compressed with Third-Party Filters

To read an HDF5 dataset compressed with a third-party filter, install the filter plugin on your system and set the environment variable.

To get information about filters associated with a dataset, use the `h5disp` function. For example, get the filter information for the `myFile.h5` dataset. The `Filters` field indicates that the filter is registered with The HDF Group. If the required filter plugin is not installed, MATLAB will throw an error indicating that the filter is not available.

```
h5disp("myFile.h5", "/SomeDataset")
```

```
HDF5 myFile.h5
Dataset 'SomeDataset'
  Size: 250x250x181
  MaxSize: 250x250xInf
  Datatype: H5T_IEEE_F64LE (double)
  ChunkSize: 250x250x3
  Filters: unrecognized filter (H5Z-ZFP-1.0.1 (ZFP-0.5.5) github.com/LLNL/H5Z-ZFP)
  FillValue: 0.000000
```

Note *unrecognized filter* indicates that the filter is not one of the HDF5 internal filters (e.g., Deflate); it does not indicate that the filter is not available on your system.

Once the necessary filter plugins are installed and configured, you can use your typical workflows to read the HDF5 dataset. For more information about reading HDF5 data, see “Import HDF5 Files” on page 7-28.

Write Datasets Compressed with Third-Party Filters

You can create and write an HDF5 dataset using either the high-level interface (such as `h5create` and `h5write`) or low-level interface (such as `H5D.create` and `H5D.write`). To write a dataset with a third-party filter, first identify the filter ID and parameters from The HDF Group - Filters page.

For example, create an HDF5 dataset for a time series of 2-D arrays that grows with time. Use data chunking to enable an unlimited third dimension, and use a ZFP filter to compress the data chunks, as shown in this illustration.

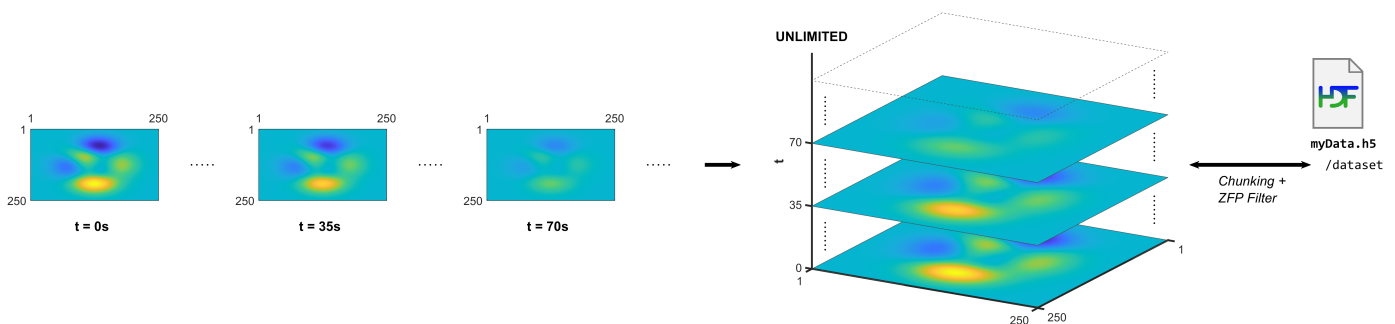

1 Install ZFP Filter Plugin

First, check if the ZFP filter is available on your system.

```
H5Z.filter_avail(32013)
```

```
ans =
     0
```

If the function returns 1, the plugin is installed and available on your system. If it returns 0, install the ZFP filter plugin.

2 Create HDF5 Dataset

When you create an HDF5 dataset using filters, its list of filters is stored as a dataset property. You can define a filter using either the high-level or the low-level interface. To use filters, you must enable data chunking because filters are applied per chunk.

Create an HDF5 dataset using the high-level `h5create` function. Specify the chunk size using the `ChunkSize` name-value argument. Specify the filter using the `CustomFilterID` and `CustomFilterParameters` name-value arguments.

```
N = 250;
filterID = 32013; % ID of the ZFP filter
filterParams = [3 3.5 2 0 0 0 0 0 0]; % Parameters for the ZFP filter
filename = "myFile.h5";
dataset = "/dataset";

% Delete file if it exists to restart with a clean file
if exist(filename,"file")
    delete(filename);
end

% Create dataset with unlimited (infinite) dimension, chunking, and
% with ZFP compression.
h5create(filename,dataset,[N,N,Inf],"ChunkSize",[N,N,4], ...
"CustomFilterID",filterID,"CustomFilterParameters",filterParams);
```

Alternatively, if you want more control over the filter pipeline, such as adding or updating filters, you can use the low-level interface. The low-level interface has functions for adding multiple filters to the filter pipeline (`H5P.set_filter`), for getting filters or information about filters (`H5P.get_filter`, `H5Z.get_filter_info`, `H5P.get_filter_by_id`), for updating filters (`H5P.modify_filter`), and for removing filters from the pipeline (`H5P.remove_filter`).

For example, create an HDF5 dataset using the low-level interface. Specify the chunk size and the filter using `H5P.set_chunk` and `H5P.set_filter`. You can exclude a filter from any chunks in which there was a filter failure during writing by using the `H5Z_FLAG_OPTIONAL` option. With this option, the filter does not participate in the pipeline during any subsequent reading of the chunk. To error at the first chunk in which there is a filter failure, use the `H5Z_FLAG_MANDATORY` option. Subsequent data is not written.

```
N = 250;
filterID = 32013; % ID of the ZFP filter
filterParams = [3 3.5 2 0 0 0 0 0 0]; % Parameters for the ZFP filter
filename = "myFile.h5";
dataset = "/dataset";

% Delete file if it exists to restart with a clean file
if exist(filename,"file")
    delete(filename);
end
```

```

% Check that ZFP filter is available
assert(H5Z.filter_avail(filterID),"ZFP filter (ID %d) unavailable.",filterID);

% Create dataspace with unlimited (infinite) dimension
UNLIMITED = H5ML.get_constant_value("H5S_UNLIMITED");
dspaceID = H5S.create_simple(3, fliplr([N,N,0]), fliplr([N,N,UNLIMITED]));

% Build dataset creation property list with chunking and ZFP filter
dcplID = H5P.create("H5P_DATASET_CREATE");
H5P.set_chunk(dcplID, fliplr([N,N,4]));
H5P.set_filter(dcplID, filterID, "H5Z_FLAG_MANDATORY", filterParams);

% Create file and dataset
fileID = H5F.create(filename, "H5F_ACC_TRUNC", "H5P_DEFAULT", "H5P_DEFAULT");
dsetID = H5D.create(fileID, dataset, "H5T_NATIVE_DOUBLE", dspaceID, [], dcplID, "H5P_DEFAULT");

% Close open resources
H5D.close(dsetID);
H5F.close(fileID);
H5P.close(dcplID);
H5S.close(dspaceID);

```

3 Write HDF5 Dataset

Write the dataset using the typical workflow. For example, this code writes time-varying data based on the MATLAB peaks function. The for loop creates a situation similar to saving a data stream, one 2-D array at a time while time flows.

- Using the high-level interface:

```

data0 = peaks(N);
tic;
for t = 0:180
    data = data0 * cosd(t);
    h5write(filename, dataset, data, [1,1,t+1], [N,N,1]);
end
to

```

Elapsed time is 1.029668 seconds.

- Using the low-level interface:

```

data0 = peaks(N);
tic;
fileID = H5F.open(filename, "H5F_ACC_RDWR", "H5P_DEFAULT");
dsetID = H5D.open(fileID, dataset);
for t = 0:180
    data = data0 * cosd(t);
    H5D.set_extent(dsetID, fliplr([N,N,t+1]));
    dspaceID = H5D.get_space(dsetID);
    H5S.select_hyperslab(dspaceID, "H5S_SELECT_SET", fliplr([0,0,t]), [], [], fliplr([N,N,1]));
    memspaceID = H5S.create_simple(3, fliplr([N,N,1]), []);
    H5D.write(dsetID, "H5ML_DEFAULT", memspaceID, dspaceID, "H5P_DEFAULT", data);
end
H5S.close(dspaceID);
H5D.close(dsetID);
H5F.close(fileID);
toc

```

```
Elapsed time is 0.598005 seconds.
```

The low-level workflow is more efficient because it requires opening and closing the file and the dataset only once, before and after the loop, respectively. In the high-level workflow, these operations are performed each time `h5write` is called. The low-level interface also allows setting the chunk cache size, which can improve the performance.

4 *Read and Display HDF5 Dataset*

You can read HDF5 datasets compressed using dynamically loaded filters like any other dataset, as long as relevant filter plugins are installed and the environment variable `HDF5_PLUGIN_PATH` is set.

```
data = h5read(filename,dataset,[50,25,1],[3,5,2],[50,40,45])
```

```
data(:,:,1) =  
    0.0145    0.1045   -3.0375   -5.4901   -0.7706  
   -0.2130   -0.6894    3.7574    0.1285    2.3196  
   -0.2966   -2.3229    0.5124    0.4879    2.4735  
data(:,:,2) =  
    0.0102    0.0739   -2.1478   -3.8821   -0.5449  
   -0.1506   -0.4875    2.6569    0.0909    1.6402  
   -0.2097   -1.6425    0.3623    0.3450    1.7490
```

See Also

`h5create` | `h5disp` | `h5read` | `h5write`

Map HDF4 to MATLAB Syntax

Each HDF4 API includes many individual routines that you use to read data from files, write data to files, and perform other related functions. For example, the HDF4 Scientific Data (SD) API includes separate C routines to open (`SDopen`), close (`SDend`), and read data (`SDreaddata`). For the SD API and the HDF-EOS GD and SW APIs, MATLAB provides functions that map to individual C routines in the HDF4 library. These functions are implemented in the `matlab.io.hdf4.sd`, `matlab.io.hdfeos.gd`, and `matlab.io.hdfeos.sw` packages. For example, the SD API includes the C routine `SDendaccess` to close an HDF4 data set:

```
status = SDendaccess(sds_id); /* C code */
```

To call this routine from MATLAB, use the MATLAB function, `matlab.io.hdf4.sd.endAccess`. The syntax is similar:

```
sd.endAccess(sdsID)
```

For the remaining supported HDF4 APIs, MATLAB provides a single function that serves as a gateway to all the routines in the particular HDF4 API. For example, the HDF Annotations (AN) API includes the C routine `ANend` to terminate access to an AN interface:

```
status = ANend(an_id); /* C code */
```

To call this routine from MATLAB, use the MATLAB function associated with the AN API, `hdfan`. You must specify the name of the routine, minus the API acronym, as the first argument and pass any other required arguments to the routine in the order they are expected. For example,

```
status = hdfan('end',an_id);
```

Some HDF4 API routines use output arguments to return data. Because MATLAB does not support output arguments, you must specify these arguments as return values.

For example, the `ANget_tagref` routine returns the tag and reference number of an annotation in two output arguments, `ann_tag` and `ann_ref`. Here is the C code:

```
status = ANget_tagref(an_id,index,annot_type,ann_tag,ann_ref);
```

To call this routine from MATLAB, change the output arguments into return values:

```
[tag,ref,status] = hdfan('get_tagref',AN_id,index,annot_type);
```

Specify the return values in the same order as they appear as output arguments. The function status return value is always specified as the last return value.

Import HDF4 Files Using Low-Level Functions

This example shows how to read data from a Scientific Data Set in an HDF4 file, using the functions in the `matlab.io.hdf4.sd` package. In HDF4 terminology, the numeric arrays stored in HDF4 files are called data sets.

Add Package to Import List

Add the `matlab.io.hdf4.*` path to the import list.

```
import matlab.io.hdf4.*
```

Subsequent calls to functions in the `matlab.io.hdf4.sd` package need only be prefixed with `sd`, rather than the entire package path.

Open HDF4 File

Open the example HDF4 file, `sd.hdf`, and specify read access, using the `matlab.io.hdf4.sd.start` function. This function corresponds to the SD API routine, `SDstart`.

```
sdID = sd.start('sd.hdf', 'read');
```

`sd.start` returns an HDF4 SD file identifier, `sdID`.

Get Information About HDF4 File

Get the number of data sets and global attributes in the file, using the `matlab.io.hdf4.sd.fileInfo` function. This function corresponds to the SD API routine, `SDfileinfo`.

```
[ndatasets,ngatts] = sd.fileInfo(sdID)
```

```
ndatasets = 4
```

```
ngatts = 1
```

The file, `sd.hdf`, contains four data sets and one global attribute,

Get Attributes from HDF4 File

Get the contents of the first global attribute. HDF4 uses zero-based indexing, so an index value of 0 specifies the first index.

HDF4 files can optionally include information, called *attributes*, that describes the data that the file contains. Attributes associated with an entire HDF4 file are *global* attributes. Attributes associated with a data set are *local* attributes.

```
attr = sd.readAttr(sdID,0)
```

```
attr =  
'02-Sep-2010 11:13:16'
```

Select Data Sets to Import

Determine the index number of the data set named `temperature`. Then, get the identifier of that data set.

```
idx = sd.nameToIndex(sdID, 'temperature');  
sdsID = sd.select(sdID, idx);
```

`sd.select` returns an HDF4 SD data set identifier, `sdsID`.

Get Information About Data Set

Get information about the data set identified by `sdsID` using the `matlab.io.hdf4.sd.getInfo` function. This function corresponds to the SD API routine, `SDgetinfo`.

```
[name, dims, datatype, nattrs] = sd.getInfo(sdsID)
```

```
name =  
'temperature'
```

```
dims = 1×2  
  
    20    10
```

```
datatype =  
'double'
```

```
nattrs = 11
```

`sd.getInfo` returns information about the name, size, data type, and number of attributes of the data set.

Read Entire Data Set

Read the entire contents of the data set specified by the data set identifier, `sdsID`.

```
data = sd.readData(sdsID);
```

Read Portion of Data Set

Read a 2-by-4 portion of the data set, starting from the first column in the second row. Use the `matlab.io.hdf4.sd.readData` function, which corresponds to the SD API routine, `SDreaddata`. The `start` input is a vector of index values specifying the location in the data set where you want to start reading data. The `count` input is a vector specifying the number of elements to read along each data set dimension.

```
start = [0 1];  
count = [2 4];  
data2 = sd.readData(sdsID, start, count)
```

```
data2 = 2×4  
  
    21    41    61    81  
    22    42    62    82
```

Close HDF4 Data Set

Close access to the data set, using the `matlab.io.hdf4.sd.endAccess` function. This function corresponds to the SD API routine, `SDendaccess`. You must close access to all the data sets in and HDF4 file before closing the file.

```
sd.endAccess(sdsID)
```

Close HDF4 File

Close the HDF4 file using the `matlab.io.hdf4.sd.close` function. This function corresponds to the SD API routine, `SDend`.

```
sd.close(sdID)
```

See Also

`sd.getInfo` | `sd.readData` | `sd.endAccess` | `sd.close` | `sd.start` | `sd.fileInfo`

More About

- “Map HDF4 to MATLAB Syntax” on page 7-64

About HDF4 and HDF-EOS

Hierarchical Data Format (HDF4) is a general-purpose, machine-independent standard for storing scientific data in files, developed by the National Center for Supercomputing Applications (NCSA). For more information about these file formats, read the HDF documentation at the HDF Web site (www.hdfgroup.org).

HDF-EOS is an extension of HDF4 that was developed by the National Aeronautics and Space Administration (NASA) for storage of data returned from the Earth Observing System (EOS). For more information about this extension to HDF4, see the HDF-EOS documentation at the NASA Web site (www.hdfeos.org).

HDF4 Application Programming Interfaces (APIs) are libraries of C routines. To import or export data, you must use the functions in the HDF4 API associated with the particular HDF4 data type you are working with. Each API has a particular programming model, that is, a prescribed way to use the routines to write data sets to the file. MATLAB functions allow you to access specific HDF4 APIs.

To use the MATLAB HDF4 functions effectively, you must be familiar with the HDF library. For detailed information about HDF4 features and routines, refer to the documentation at the HDF Web site.

Export to HDF4 Files

In this section...

“Write MATLAB Data to HDF4 File” on page 7-69

“Manage HDF4 Identifiers” on page 7-70

Write MATLAB Data to HDF4 File

This example shows how to write MATLAB® arrays to a Scientific Data Set in an HDF4 file.

Add Package to Import List

Add the `matlab.io.hdf4.*` path to the import list.

```
import matlab.io.hdf4.*
```

Prefix subsequent calls to functions in the `matlab.io.hdf4.sd` package with `sd`, rather than the entire package path.

Create HDF4 File

Create a new HDF4 file using the `matlab.io.hdf4.sd.start` function. This function corresponds to the SD API routine, `SDstart`.

```
sdID = sd.start('mydata.hdf','create');
```

`sd.start` creates the file and returns a file identifier named `sdID`.

To open an existing file instead of creating a new one, call `sd.start` with `'write'` access instead of `'create'`.

Create HDF4 Data Set

Create a data set in the file for each MATLAB array you want to export. If you are writing to an existing data set, you can skip ahead to the next step. In this example, create one data set for the array of sample data, `A`, using the `matlab.io.hdf4.sd.create` function. This function corresponds to the SD API routine, `SDcreate`. The `ds_type` argument is a character vector specifying the MATLAB data type of the data set.

```
A = [1 2 3 4 5 ; 6 7 8 9 10 ; 11 12 13 14 15];
ds_name = 'A';
ds_type = 'double';
ds_dims = size(A);
sdsID = sd.create(sdID,ds_name,ds_type,ds_dims);
```

`sd.create` returns an HDF4 SD data set identifier, `sdsID`.

Write MATLAB Data to HDF4 File

Write data in `A` to the data set in the file using the `matlab.io.hdf4.sd.writedata` function. This function corresponds to the SD API routine, `SDwritedata`. The `start` argument specifies the zero-based starting index.

```
start = [0 0];  
sd.writeData(sdsID,start,A);
```

`sd.writeData` queues the write operation. Queued operations execute when you close the HDF4 file.

Write MATLAB Data to Portion of Data Set

Replace the second row of the data set with the vector `B`. Use a `start` input value of `[1 0]` to begin writing at the second row, first column. `start` uses zero-based indexing.

```
B = [9 9 9 9];  
start = [1 0];  
sd.writeData(sdsID,start,B);
```

Write Metadata to HDF4 File

Create a global attribute named `creation_date`, with a value that is the current date and time. Use the `matlab.io.hdf4.sd.setAttr` function, which corresponds to the SD API routine, `SDsetattr`.

```
sd.setAttr(sdsID,'creation_date',string(datetime('now')));
```

`sd.Attr` creates a file attribute, also called a global attribute, associated with the HDF4 file identified by `sdID`.

Associate a predefined attribute, `cordsys`, to the data set identified by `sdsID`. Possible values of this attribute include the text strings `'cartesian'`, `'polar'`, and `'spherical'`.

```
attr_name = 'cordsys';  
attr_value = 'polar';  
sd.setAttr(sdsID,attr_name,attr_value);
```

Close HDF4 Data Set

Close access to the data set, using the `matlab.io.hdf4.sd.endAccess` function. This function corresponds to the SD API routine, `SDendaccess`. You must close access to all the data sets in and HDF4 file before closing the file.

```
sd.endAccess(sdsID);
```

Close HDF4 File

Close the HDF4 file using the `matlab.io.hdf4.sd.close` function. This function corresponds to the SD API routine, `SDend`.

```
sd.close(sdID);
```

Closing an HDF4 file executes all the write operations that have been queued using `SDwritedata`.

Manage HDF4 Identifiers

MATLAB supports utility functions that make it easier to use HDF4 in the MATLAB environment.

- “View All Open HDF4 Identifiers” on page 7-71
- “Close All Open HDF4 Identifiers” on page 7-71

View All Open HDF4 Identifiers

Use the gateway function to the MATLAB HDF4 utility API, `hdfml`, and specify the name of the `listinfo` routine as an argument to view all the currently open HDF4 identifiers. MATLAB updates this list whenever HDF identifiers are created or closed. In this example only two identifiers are open.

```
hdfml('listinfo')  
  
No open RI identifiers  
No open GR identifiers  
No open grid identifiers  
No open grid file identifiers  
No open annotation identifiers  
No open AN identifiers  
Open scientific dataset identifiers:  
  262144  
Open scientific data file identifiers:  
  393216  
No open Vdata identifiers  
No open Vgroup identifiers  
No open Vfile identifiers  
No open point identifiers  
No open point file identifiers  
No open swath identifiers  
No open swath file identifiers  
No open access identifiers  
No open file identifiers
```

Close All Open HDF4 Identifiers

Close all the currently open HDF4 identifiers in a single call using the gateway function to the MATLAB HDF4 utility API, `hdfml`. Specify the name of the `closeall` routine as an argument:

```
hdfml('closeall')
```

See Also

`sd.start` | `sd.create` | `sd.writeData` | `sd.setAttr` | `sd.close` | `sd.endAccess` | `hdfml`

More About

- “Map HDF4 to MATLAB Syntax” on page 7-64

Audio and Video

- “Read and Write Audio Files” on page 8-2
- “Record and Play Audio” on page 8-4
- “Read Video Files” on page 8-8
- “Supported Video and Audio File Formats” on page 8-12
- “Convert Between Image Sequences and Video” on page 8-16

Read and Write Audio Files

Write data to an audio file, get information about the file, and then read the data back into the MATLAB workspace.

Write to Audio File

Load sample data from the file, `handel.mat`

```
load handel.mat
```

The workspace now contains a matrix of audio data, `y`, and a sample rate, `Fs`.

Use the `audiowrite` function to write the data to a WAVE file named `handel.wav` in the current folder.

```
audiowrite("handel.wav",y,Fs)
clear y Fs
```

The `audiowrite` function also can write to other audio file formats. For a full list of viable formats, see “Supported File Formats for Import and Export” on page 1-2.

Get Information About Audio File

Use the `audioinfo` function to get information about the WAVE file, `handel.wav`.

```
info = audioinfo("handel.wav")

info =
    Filename: 'pwd\handel.wav'
  CompressionMethod: 'Uncompressed'
    NumChannels: 1
    SampleRate: 8192
   TotalSamples: 73113
    Duration: 8.9249
         Title: []
        Comment: []
         Artist: []
   BitsPerSample: 16
```

`audioinfo` returns a 1-by-1 structure array. The `SampleRate` field indicates the sample rate of the audio data, in hertz. The `Duration` field indicates the duration of the file, in seconds.

Read Audio File

Use the `audioread` function to read the file, `handel.wav`. The `audioread` function can support other file formats. For a full list of viable formats, see “Supported File Formats for Import and Export” on page 1-2.

```
[y,Fs] = audioread("handel.wav");
```

Play the audio.

```
sound(y,Fs)
```

You also can read files interactively. Select  **Import Data** or double-click the file name in the Current Folder browser.

Plot Audio Data

Create a vector `t` the same length as `y`, that represents elapsed time.

```
t = 0:seconds(1/Fs):seconds(info.Duration);  
t = t(1:end-1);
```

Plot the audio data as a function of time.

```
plot(t,y)  
xlabel('Time')  
ylabel('Audio Signal')
```

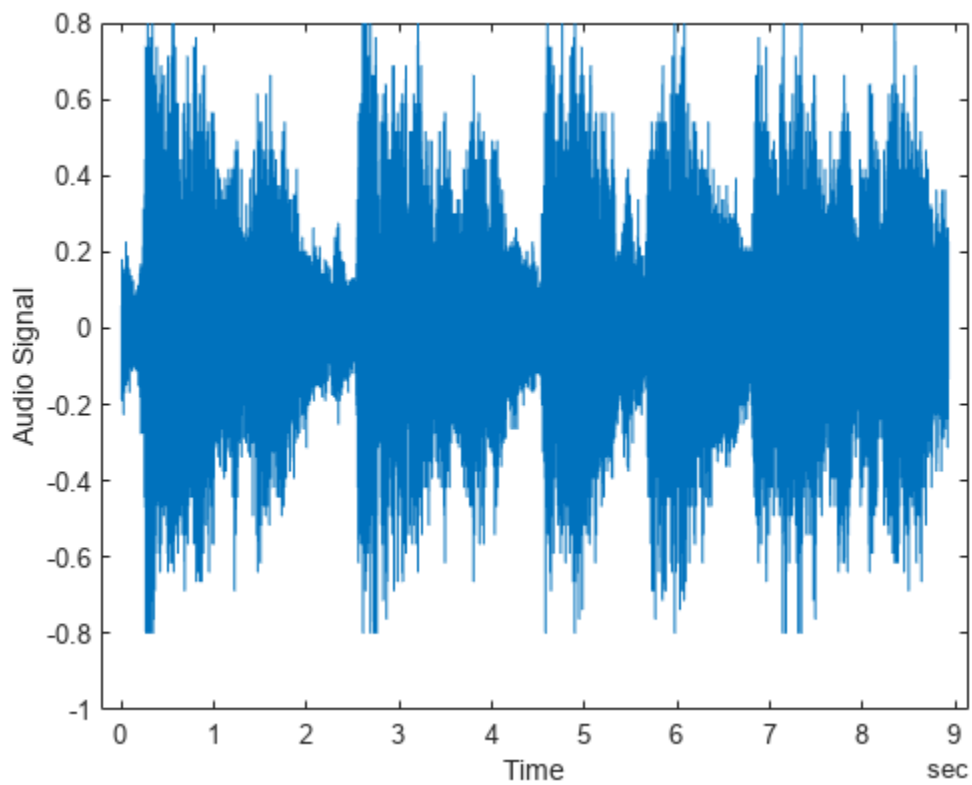

See Also

[audioinfo](#) | [audioread](#) | [audiowrite](#)

Related Examples

- “Import Images, Audio, and Video Interactively” on page 1-7

Record and Play Audio

Record and play audio data for processing in MATLAB from audio input and output devices on your system. Audio playback and recording in MATLAB Online and MATLAB Web App Server™ are supported in Google Chrome™.

In this section...

“Record Audio” on page 8-4

“Play Audio” on page 8-6

“Record or Play Audio within a Function” on page 8-6

Record Audio

Record data from an audio input device such as a microphone connected to your system:

- 1 Create an `audiorecorder` object.
- 2 Call the `record` or `recordblocking` method, where:
 - `record` returns immediate control to the calling function or the command prompt even as recording proceeds. Specify the length of the recording in seconds, or end the recording with the `stop` method. Optionally, call the `pause` and `resume` methods. The recording is performed asynchronously.
 - `recordblocking` retains control until the recording is complete. Specify the length of the recording in seconds. The recording is performed synchronously.
- 3 Create a numeric array corresponding to the signal data using the `getaudiodata` method.

The following examples show how to use the `recordblocking` and `record` methods.

Record Microphone Input

This example shows how to record microphone input, play back the recording, and store the recorded audio signal in a numeric array. You must first connect a microphone to your system.

Create an `audiorecorder` object with default properties named `recObj` for recording audio input.

```
recObj = audiorecorder
```

```
recObj =
```

```
audiorecorder with properties:
```

```
    SampleRate: 8000
    BitsPerSample: 8
    NumChannels: 1
    DeviceID: -1
    CurrentSample: 1
    TotalSamples: 0
    Running: 'off'
    StartFcn: []
    StopFcn: []
    TimerFcn: []
    TimerPeriod: 0.0500
```

```

    Tag: ''
  UserData: []
    Type: 'audiorecorder'

```

`audiorecorder` creates an 8000 Hz, 8-bit, 1-channel `audiorecorder` object.

Record your voice for 5 seconds.

```

recDuration = 5;
disp("Begin speaking.")
recordblocking(recObj, recDuration);
disp("End of recording.")

```

Play the recording.

```
play(recObj);
```

Store data in double-precision array `y`.

```
y = getaudiodata(recObj);
```

Plot the audio samples.

```
plot(y);
```

Record Two Channels from Different Sound Cards

To record audio independently from two different sound cards, with a microphone connected to each:

- 1 Call `audiodevinfo` to list the available sound cards. For example, this code returns a structure array containing all input and output audio devices on your system.

```
info = audiodevinfo;
```

Identify the sound cards you want to use by name, and note their ID values.

- 2 Create two `audiorecorder` objects. For example, this code creates the `audiorecorder` object `recorder1` for recording a single channel from device 3 at 44.1 kHz and 16 bits per sample. The code then creates the `audiorecorder` object `recorder2` for recording a single channel from device 4 at 48 kHz.

```

recorder1 = audiorecorder(44100,16,1,3);
recorder2 = audiorecorder(48000,16,1,4);

```

- 3 Record each audio channel separately.

```

record(recorder1);
record(recorder2);
pause(5);

```

The recordings occur simultaneously as the first call to `record` does not block.

- 4 Stop the recordings.

```

stop(recorder1);
stop(recorder2);

```

Specify the Quality of the Recording

By default, an `audiorecorder` object uses a sample rate of 8000 Hz, a depth of 8 bits (8 bits per sample), and a single audio channel. With these settings, the required amount of data storage is low. For higher quality recordings, increase the sample rate or bit depth.

For example, compact disks use a sample rate of 44,100 Hz, a 16-bit depth, and two audio channels. Create an `audiorecorder` object to record with those settings.

```
myRecObj = audiorecorder(44100,16,2);
```

For more information on the available properties and values, see the `audiorecorder` reference page.

Play Audio

After you import or record audio, MATLAB supports several ways to listen to the data:

- For simple playback using a single function call, use `sound` or `soundsc`. For example, load a sample MAT-file that contains signal and sample rate data, and listen to the audio.

```
load chirp.mat
sound(y,Fs)
```

- For more flexibility during playback, including the ability to pause, resume, or define callbacks, use the `audioplayer` function. Create an `audioplayer` object, then call methods to play the audio. For example, listen to the `gong` sample file.

```
load gong.mat
gong = audioplayer(y,Fs);
play(gong);
```

For an additional example, see “Record or Play Audio within a Function” on page 8-6.

If you do not specify the sample rate, `sound` plays back at 8192 Hz. For any playback, specify smaller sample rates to play back more slowly, and larger sample rates to play back more quickly.

Note Most sound cards support sample rates between approximately 5000 and 192,000 Hz. Specifying sample rates outside this range can produce unexpected results.

Record or Play Audio within a Function

If you create an `audioplayer` or `audiorecorder` object inside a function, the object exists only for the duration of the function. For example, create a player function called `playFile` and a simple callback function `showSeconds`.

```
function playFile(myfile)
    load(myfile)

    obj = audioplayer(y,Fs);
    obj.TimerFcn = 'showSeconds';
    obj.TimerPeriod = 1;

    play(obj);
```

```
end
```

```
function showSeconds  
    disp("tick")  
end
```

Call `playFile` from the command prompt to play the file `handel.mat`.

```
playFile("handel.mat")
```

At the recorded sample rate of 8192 samples per second, playing the 73,113 samples in the file takes approximately 8.9 seconds. However, the `playFile` function typically ends before playback completes, and clears the `audioplayer` object `obj`.

For complete playback or recording, consider these options:

- Use `playblocking` or `recordblocking` instead of `play` or `record`. The blocking methods retain control until playing or recording completes. If you block control, you cannot issue any other commands or methods (such as `pause` or `resume`) during the playback or recording.
- Create an output argument for your function that generates an object in the base workspace. For example, modify the `playFile` function to include an output argument.

```
function obj = playFile(myfile)
```

Call the function.

```
h = playFile("handel.mat");
```

Because `h` exists in the base workspace, you can pause playback from the command prompt.

```
pause(h)
```

See Also

`audioplayer` | `sound` | `soundsc` | `audiorecorder`

More About

- “Read and Write Audio Files” on page 8-2

Read Video Files

Read frames from a video starting at a specific time or frame index, read frames within a specified interval, or read all the frames in the video.

Read Frames Beginning at Specified Time or Frame Index

Read part of a video file starting 0.5 second from the beginning of the file. Then, read the video starting from frame index 100 to the end of the video file.

Construct a `VideoReader` object associated with the sample file `'xylophone.mp4'`.

```
vidObj = VideoReader('xylophone.mp4');
```

Specify that reading should begin 0.5 second from the beginning of the file by setting the `CurrentTime` property.

```
vidObj.CurrentTime = 0.5;
```

Read video frames until the end of the file is reached by using the `readFrame` method.

```
while hasFrame(vidObj)
    vidFrame = readFrame(vidObj);
    imshow(vidFrame)
    pause(1/vidObj.FrameRate);
end
```



Alternatively, you can read frames from a video starting at a specified frame index to the end of the video by using the `read` method. Specify the indices to read as `[100 Inf]`. The `read` method returns all the frames starting at 100 to the end of the video file.

```
vidframes = read(vidObj,[100 Inf]);
```

Read Frames Within Specified Interval

Read a part of a video file by specifying the time or frame interval.

Read the video frames between 0.6 and 0.9 seconds. First, create a video reader object and a structure array to hold the frames.

```
vidObj = VideoReader('xylophone.mp4');
s = struct('cdata', zeros(vidObj.Height, vidObj.Width, 3, 'uint8'), 'colormap', []);
```

Then, specify that reading should begin 0.6 second from the beginning of the file by setting the `CurrentTime` property.

```
vidObj.CurrentTime = 0.6;
```

Read one frame at a time until `CurrentTime` reaches 0.9 second. Append data from each video frame to the structure array. View the number of frames in the structure array. `s` is a 1-by-10 structure indicating that 10 frames were read. For information on displaying the frames in the structure `s` as a movie, see the `movie` function reference page.

```
k = 1;
while vidObj.CurrentTime <= 0.9
    s(k).cdata = readFrame(vidObj);
    k = k+1;
end
whos s
```

Name	Size	Bytes	Class	Attributes
s	1x10	2305344	struct	

Alternatively, you can read all the frames in a specified interval by using frame indices. For example, specify the second argument of `read` as `[18 27]`. The `read` method returns a `FrameSize`-by-10 array indicating that 10 frames were read.

```
frames = read(vidObj, [18 27]);
whos frames
```

Name	Size	Bytes	Class	Attributes
frames	240x320x3x10	2304000	uint8	

Read All Frames

Read all the frames from video, one frame at a time or all the frames at once.

Create a video reader object and display the total number of frames in the video.

```
vidObj = VideoReader('xylophone.mp4');
vidObj.NumFrames

ans = 141
```

Read all the frames, one frame at a time, by using the `readFrame` method, and display the frames.

```
while hasFrame(vidObj)
    frame = readFrame(vidObj);
    imshow(frame)
```

```

    pause(1/vidObj.FrameRate);
end

```



Alternatively, you can read all the video frames at once. The `read` method returns a `FrameSize-by-141` array of video frames.

```

allFrames = read(vidObj);
whos allFrames

```

Name	Size	Bytes	Class	Attributes
allFrames	240x320x3x141	32486400	uint8	

Troubleshooting and Tips for Video Reading

- The `hasFrame` method might return logical 1 (true) when the value of the `CurrentTime` property is equal to the value of the `Duration` property. This is due to a limitation in the underlying APIs used.
- Seeking to the last frame in a video file by setting the `CurrentTime` property to a value close to the `Duration` value is not recommended. For some files, this operation returns an error indicating that the end-of-file has been reached, even though the `CurrentTime` value is less than the `Duration` value. This typically occurs if the file duration is larger than the duration of the video stream, and there is no video available to read near the end of the file.
- Use of the `Duration` property to limit the reading of data from a video file is not recommended. Use the `hasFrame` method to check whether there is a frame available to read. It is best to read data until the file reports that there are no more frames available to read.
- Video Reading Performance on Windows® Systems: To achieve better video reader performance on Windows for MP4 and MOV files, MATLAB® uses the system's graphics hardware for decoding. However, in some cases using the graphics card for decoding can result in poorer performance depending on the specific graphics hardware on the system. If you notice slower video reader performance on your system, turn off the hardware acceleration by typing:

`matlab.video.read.UseHardwareAcceleration('off')`. You can reenable hardware acceleration by typing: `matlab.video.read.UseHardwareAcceleration('on')`.

See Also

`VideoReader` | `mmfileinfo` | `movie` | `read` | `readFrame`

More About

- “Supported Video and Audio File Formats” on page 8-12

Supported Video and Audio File Formats

Video and audio files in MATLAB and their supported file formats and codecs.

Video Data in MATLAB

What Are Video Files?

For video data, the term “file format” often refers to either the *container format* or the *codec*. A container format describes the layout of the file, while a codec describes how to encode/decode the video data. Many container formats can hold data encoded with different codecs.

To read a video file, any application must:

- Recognize the container format (such as AVI).
- Have access to the codec that can decode the video data stored in the file. Some codecs are part of standard Windows and Macintosh system installations, and allow you to play video in Windows Media Player or QuickTime. In MATLAB, `VideoReader` can access most, but not all, of these codecs.
- Properly use the codec to decode the video data in the file. `VideoReader` cannot always read files associated with codecs that were not part of your original system installation.

Formats That VideoReader Supports

Use `VideoReader` to read video files in MATLAB. The file formats that `VideoReader` supports vary by platform, and have no restrictions on file extensions.

Platforms	File Formats
All Platforms	AVI, including uncompressed, indexed, grayscale, and Motion JPEG-encoded video (.avi) Motion JPEG 2000 (.mj2)
All Windows	MPEG-1 (.mpg) Windows Media Video (.wmv, .asf, .asx) Any format supported by Microsoft DirectShow
Windows 7 or later	MPEG-4, including H.264 encoded video (.mp4, .m4v) Apple QuickTime Movie (.mov) Any format supported by Microsoft Media Foundation

Platforms	File Formats
Macintosh	<p>Most formats supported by QuickTime Player, including:</p> <ul style="list-style-type: none"> MPEG-1 (.mpg) MPEG-4, including H.264 encoded video (.mp4, .m4v) Apple QuickTime Movie (.mov) 3GPP 3GPP2 AVCHD DV <p>Note: For OS X Yosemite (Version 10.10) and later, MPEG-4/H.264 files written using <i>VideoWriter</i>, play correctly, but display an inexact frame rate.</p>
Linux	<p>Any format supported by your installed plug-ins for GStreamer 1.0 or higher, as listed on https://gstreamer.freedesktop.org/documentation/plugins_doc.html, including Ogg Theora (.ogg).</p>

View Codec Associated with Video File

This example shows how to view the codec associated with a video file, using the `mmfileinfo` function.

Store information about the sample video file, `shuttle.avi`, in a structure array named `info`. The `info` structure contains the following fields: `Filename`, `Path`, `Duration`, `Audio` and `Video`.

```
info = mmfileinfo('shuttle.avi');
```

Show the properties in the command window by displaying the fields of the `info` structure. For example, to view information under the `Video` field, type `info.Video`

```
info.Video
```

```
ans = struct with fields:
  Format: 'MJPG'
  Height: 288
  Width: 512
```

The file, `shuttle.avi`, uses the Motion JPEG codec.

Troubleshooting: Errors Reading Video File

You might be unable to read a video file if MATLAB cannot access the appropriate codec. 64-bit applications use 64-bit codec libraries, while 32-bit applications use 32-bit codec libraries. For example, when working with 64-bit MATLAB, you cannot read video files that require access to a 32-bit codec installed on your system. To read these files, try one of the following:

- Install a 64-bit codec that supports this file format. Then, try reading the file using 64-bit MATLAB.

- Re-encode the file into a different format with a 64-bit codec that is installed on your computer.

Sometimes, VideoReader cannot open a video file for reading on Windows platforms. This might occur if you have installed a third-party codec that overrides your system settings. Uninstall the codec and try opening the video file in MATLAB again.

Audio Data in MATLAB

What Are Audio Files?

The audio signal in a file represents a series of *samples* that capture the amplitude of the sound over time. The *sample rate* is the number of discrete samples taken per second and given in hertz. The precision of the samples, measured by the *bit depth* (number of bits per sample), depends on the available audio hardware.

MATLAB audio functions read and store single-channel (mono) audio data in an m -by-1 column vector, and stereo data in an m -by-2 matrix. In either case, m is the number of samples. For stereo data, the first column contains the left channel, and the second column contains the right channel.

Typically, each sample is a double-precision value between -1 and 1. In some cases, particularly when the audio hardware does not support high bit depths, audio files store the values as 8-bit or 16-bit integers. The range of the sample values depends on the available number of bits. For example, samples stored as `uint8` values can range from 0 to 255 ($2^8 - 1$). The MATLAB `sound` and `soundsc` functions support only single- or double-precision values between -1 and 1. Other audio functions support multiple data types, as indicated on the function reference pages.

Formats That audioread Supports

Use `audioread` to read audio files in MATLAB. The `audioread` function supports these file formats.

Platform Support	File Format
All platforms	AIFC (.aifc)
	AIFF (.aiff, .aif)
	AU (.au)
	FLAC (.flac)
	OGG (.ogg)
	OPUS (.opus)
	WAVE (.wav)
Windows 7 (or later), Macintosh, and Linux	MP3 (.mp3)
	MPEG-4 AAC (.m4a, .mp4)

On Windows platforms prior to Windows 7, `audioread` does not read WAVE files with MP3 encoded data.

On Windows 7 (or later) platforms, `audioread` might also read any files supported by Windows Media Foundation.

On Linux platforms, `audioread` might also read any files supported by GStreamer.

`audioread` can extract audio from MPEG-4 (`.mp4`, `.m4v`) video files on Windows 7 or later, Macintosh, and Linux, and from Windows Media Video (`.wmv`) and AVI (`.avi`) files on Windows 7 (or later) and Linux platforms.

See Also

`VideoReader` | `audioread` | `mmfileinfo` | `audioinfo`

More About

- “Read Video Files” on page 8-8
- “Read and Write Audio Files” on page 8-2

Convert Between Image Sequences and Video

Convert between video files and sequences of image files using `VideoReader` and `VideoWriter`.

The sample file named `shuttle.avi` contains 121 frames. Convert the frames to image files using `VideoReader` and the `imwrite` function. Then, convert the image files to an AVI file using `VideoWriter`.

Setup

Create a temporary working folder to store the image sequence.

```
workingDir = tempname;
mkdir(workingDir)
mkdir(workingDir, 'images')
```

Create VideoReader

Create a `VideoReader` to use for reading frames from the file.

```
shuttleVideo = VideoReader('shuttle.avi');
```

Create the Image Sequence

Loop through the video, reading each frame into a width-by-height-by-3 array named `img`. Write out each image to a JPEG file with a name in the form `imgN.jpg`, where `N` is the frame number.

```
| img001.jpg|
| img002.jpg|
| ...|
| img121.jpg|

ii = 1;

while hasFrame(shuttleVideo)
    img = readFrame(shuttleVideo);
    filename = [sprintf('%03d',ii) '.jpg'];
    fullname = fullfile(workingDir, 'images', filename);
    imwrite(img, fullname)    % Write out to a JPEG file (img1.jpg, img2.jpg, etc.)
    ii = ii+1;
end
```

Find Image File Names

Find all the JPEG file names in the `images` folder. Convert the set of image names to a cell array.

```
imageNames = dir(fullfile(workingDir, 'images', '*.jpg'));
imageNames = {imageNames.name}';
```

Create New Video with the Image Sequence

Construct a `VideoWriter` object, which creates a Motion-JPEG AVI file by default.

```
outputVideo = VideoWriter(fullfile(workingDir, 'shuttle_out.avi'));
outputVideo.FrameRate = shuttleVideo.FrameRate;
open(outputVideo)
```

Loop through the image sequence, load each image, and then write it to the video.

```
for ii = 1:length(imageNames)
    img = imread(fullfile(workingDir, 'images', imageNames{ii}));
    writeVideo(outputVideo, img)
end
```

Finalize the video file.

```
close(outputVideo)
```

View the Final Video

Construct a reader object.

```
shuttleAvi = VideoReader(fullfile(workingDir, 'shuttle_out.avi'));
```

Create a MATLAB® movie struct from the video frames.

```
ii = 1;
while hasFrame(shuttleAvi)
    mov(ii) = im2frame(readFrame(shuttleAvi));
    ii = ii+1;
end
```

Resize the current figure and axes based on the video's width and height, and view the first frame of the movie.

```
figure
imshow(mov(1).cdata, 'Border', 'tight')
```



Play back the movie once at the video's frame rate.

```
movie(mov, 1, shuttleAvi.FrameRate)
```

Credits

Video of the Space Shuttle courtesy of NASA.

XML Documents

- “Import an XML File into a Document Object Model” on page 9-2
- “Export a Document Object Model to an XML File” on page 9-6

Import an XML File into a Document Object Model

You can import an XML file into a Document Object Model (DOM) document node by using a `matlab.io.xml.dom.Parser` object or the `xmlread` function.

The `matlab.io.xml.dom.Parser` class belongs to the MATLAB API for XML Processing (MAXP). When you use a MAXP Parser object to read an XML file, the resulting DOM document node is represented as a `matlab.io.xml.dom.Document` object. For a list of the classes that you can use to work with a Document object, see `matlab.io.xml.dom`. You do not need Java® software to use MAXP classes.

To work with a DOM document node object created by `xmlread`, you must use the Java API for XML Processing (JAXP). For a list of the JAXP methods and properties, see the `org.w3c.dom` package description at <https://docs.oracle.com/javase/7/docs/api>.

The XML Document Object Model

In a Document Object Model, every item in an XML file corresponds to a node. The properties and methods that you use to create and access nodes, follow standards set by the World Wide Web consortium.

For example, consider this sample XML file:

```
<productinfo>
<!-- This is a sample info.xml file. -->
<list>
<listitem>
<label color="blue">Import Wizard</label>
<callback>uiimport</callback>
<icon>ApplicationIcon.GENERIC_GUI</icon>
</listitem>
<listitem>
<label color="red">Profiler</label>
<callback>profile viewer</callback>
<icon>ApplicationIcon.PROFILER</icon>
</listitem>
</list>
</productinfo>
```

The information in the file maps to the following types of DOM nodes:

- *Element nodes* — Correspond to tag names. In the `info.xml` file, these tags correspond to element nodes:
 - `productinfo`
 - `list`
 - `listitem`
 - `label`
 - `callback`
 - `icon`

In this case, the `list` element is the parent of `listitem` element child nodes. The `productinfo` element is the root element node.

- Text nodes — Contain values associated with element nodes. Every text node is the child of an element node. For example, the `Import Wizard` text node is the child of the first `label` element node.
- Attribute nodes — Contain name and value pairs associated with an element node. For example, in the first `label` element node, `color` is the name of an attribute and `blue` is its value. Attribute nodes are not parents or children of any nodes.
- Comment nodes — Include additional text in the file, in the form `<!--Sample comment-->`.
- Document nodes — Correspond to the entire file. Use methods on the document node to create new element, text, attribute, or comment nodes.

Read an XML File Using the MAXP Parser

This example uses a `matlab.io.xml.dom.Parser` object to read an `info.xml` file into a `matlab.io.xml.dom.Document` node. The file contains several `listitem` elements. Each `listitem` element contains a `label` and `callback` element. The example uses MAXP methods to find the text content of the `callback` element that corresponds to the `label` that has text content `Plot Tools`.

Read the file into a Document object.

```
infoFile = fullfile(matlabroot, 'toolbox/matlab/general/info.xml');
infoLabel = 'Plot Tools';
infoCbK = '';
itemFound = false;
```

```
import matlab.io.xml.dom.*
xDoc = parseFile(Parser, infoFile);
```

Find all the `listitem` elements by calling the `getElementsByTagName` method, which returns a `matlab.io.xml.dom.NodeList` object.

```
allListItems = getElementsByTagName(xDoc, 'listitem');
```

For each `listitem` element, compare the text of the `label` element to `Plot Tools`. When you locate the correct label, get the `callback` text. To access an element in the `NodeList` object, use the `node` method, which uses one-based indexing. Alternatively, you can use the `item` method, which uses zero-based indexing.

```
length = allListItems.Length;
for i=1:length
    thisListItem = node(allListItems,i);
    childNode = getFirstChild(thisListItem);

    while ~isempty(childNode)
        %Filter out text, comments, and processing instructions.

        if isa(childNode, 'matlab.io.xml.dom.Element')
            %Assume that each element has a single Text child

            childText = getData(getFirstChild(childNode));

            switch getTagName(childNode)
                case 'label'
```

```

        itemFound = strcmp(childText,infoLabel);
        case 'callback'
            infoCbk = childText;
        end
    end
    childNode = getNextSibling(childNode);
end
if itemFound
    break
else
    infoCbk = '';
end
end
end

```

Display the result.

```
fprintf('Item "%s" has a callback of "%s".\n', infoLabel,infoCbk);
```

```
Item "Plot Tools" has a callback of "figure; plottools".
```

Read an XML File Using `xmlread`

This example uses `xmlread` to read the `info.xml` file into a DOM document node and Java API for XML Processing methods to find the text content of the `callback` element that corresponds to the label that has text content `Plot Tools`.

```

infoFile = fullfile(matlabroot,'toolbox/matlab/general/info.xml');
infoLabel = 'Plot Tools';
infoCbk = '';
itemFound = false;

xDoc = xmlread(infoFile);

allListItems = getElementsByTagName(xDoc,'listitem');

%The item list index is zero-based.
length = allListItems.getLength-1;
for i=0:length

    thisListItem = item(allListItems,i);
    childNode = getFirstChild(thisListItem);

    while ~isempty(childNode)
        %Filter out text, comments, and processing instructions.

        if childNode.getNodeType == childNode.ELEMENT_NODE
            %Assume that each element has a single org.w3c.dom.Text child

            childText = char(childNode.getFirstChild.getData);

            switch char(childNode.getTagname)
                case 'label'
                    itemFound = strcmp(childText,infoLabel);
                case 'callback'
                    infoCbk = childText;
            end
        end
        childNode = getNextSibling(childNode);
    end
    if itemFound
        break
    else
        infoCbk = '';
    end
end
end
fprintf('Item "%s" has a callback of "%s".\n', infoLabel,infoCbk);

```

Item "Plot Tools" has a callback of "figure; plottools".

See Also

`matlab.io.xml.dom.Document | xmlread`

Related Examples

- "Export a Document Object Model to an XML File" on page 9-6

External Websites

- <https://docs.oracle.com/javase/7/docs/api>

Export a Document Object Model to an XML File

You can export a Document Object Model (DOM) document node to an XML file by using a `matlab.io.xml.dom.DOMWriter` object or the `xmlwrite` function.

The `matlab.io.xml.dom.DOMWriter` class belongs to the MATLAB API for XML Processing (MAXP). To use a MAXP `DOMWriter` object, represent a DOM document node as a `matlab.io.xml.dom.Document` object. To create and add elements, text, and other nodes to the document node, use MAXP classes and methods. See `matlab.io.xml.dom`. You do not need Java software to use MAXP classes.

To create a DOM document that you can write by using `xmlwrite`, use `com.mathworks.xml.XMLUtils.createDocument`. To create and add nodes to the document node, use methods of the Java API for XML Processing (JAXP). See the `org.w3c.dom` package description at <https://docs.oracle.com/javase/7/docs/api>.

Create a DOM Document

Common steps for creating an XML document include:

- 1 Create a document node and define the root element. This code creates a document node by creating a MAXP `matlab.io.xml.dom.Document` object:

```
import matlab.io.xml.dom.*
docNode = Document('root_element');
```

This code creates a document node that you can use with JAXP methods:

```
docNode = com.mathworks.xml.XMLUtils.createDocument('root_element');
```

- 2 Get the node that corresponds to the root element by calling `getDocumentElement`. The root element node is required to add child nodes.
- 3 Add element, text, comment, and attribute nodes by calling methods of the document node. Useful methods include:
 - `createElement`
 - `createTextNode`
 - `createComment`
 - `setAttribute`
- 4 To append child nodes to a parent node, use `appendChild`.

Tip Text nodes are always children of element nodes. To add a text node, use `createTextNode` with the document node, and then use `appendChild` with the parent element node.

Write a DOM Document Node to an XML File Using a MAXP DOMWriter Object

This example uses a `matlab.io.xml.dom.DOMWriter` object to create an `info.xml` file for the Upslope Area Toolbox, which is described in “Display Custom Documentation”.

Create the document node and root element, `toc`.

```
import matlab.io.xml.dom.*
docNode = Document('toc');
```

Get the root element, and set the version attribute.

```
toc = docNode.getDocumentElement;
setAttribute(toc, 'version', '2.0');
```

Add the `tocitem` element node for the product page. Each `tocitem` element in this file has a `target` attribute and a child text node.

```
product = createElement(docNode, 'tocitem');
setAttribute(product, 'target', 'upslope_product_page.html');
appendChild(product, createTextNode(docNode, 'Upslope Area Toolbox'));
appendChild(toc, product);
```

Add a comment.

```
appendChild(product, createComment(docNode, ' Functions '));
```

Add a `tocitem` element node for each function.

```
functions = {'demFlow', 'facetFlow', 'flowMatrix', 'pixelFlow'};
n = numel(functions);
for idx = 1:n
    curr_node = createElement(docNode, 'tocitem');
    curr_file = [functions{idx} '_help.html'];
    setAttribute(curr_node, 'target', curr_file);

    % Child text is the function name.
    appendChild(curr_node, createTextNode(docNode, functions{idx}));
    appendChild(product, curr_node);
end
```

Export the DOM node to `info.xml`, and view the file.

```
xmlFileName = 'info.xml';
writer = matlab.io.xml.dom.DOMWriter;
writer.Configuration.FormatPrettyPrint = true;
```

```
writeToFile(writer, docNode, xmlFileName);
```

```
type('info.xml');
```

```
<?xml version="1.0" encoding="UTF-8" standalone="no" ?>
<toc version="2.0">
```

```
  <tocitem target="upslope_product_page.html">Upslope Area Toolbox
    <!-- Functions -->
    <tocitem target="demFlow_help.html">demFlow</tocitem>
    <tocitem target="facetFlow_help.html">facetFlow</tocitem>
    <tocitem target="flowMatrix_help.html">flowMatrix</tocitem>
    <tocitem target="pixelFlow_help.html">pixelFlow</tocitem>
  </tocitem>
```

methods. See `matlab.io.xml.dom`. If you use `xmlread`, use Java API for XML Processing (JAXP) methods. See the `org.w3c.dom` package description at <https://docs.oracle.com/javase/7/docs/api>.

- 3 When the DOM document contains all your changes, write the file. For a MAXP DOM document, use a `matlab.io.xml.DOMWriter` object. For a JAXP DOM document, use `xmlwrite`.

See Also

`matlab.io.xml.dom.Document` | `matlab.io.xml.dom.DOMWriter` | `xmlwrite`

Related Examples

- “Import an XML File into a Document Object Model” on page 9-2

External Websites

- <https://docs.oracle.com/javase/7/docs/api>

Memory-Mapping Data Files

- “Overview of Memory-Mapping” on page 10-2
- “Map File to Memory” on page 10-5
- “Read from Mapped File” on page 10-9
- “Write to Mapped File” on page 10-14
- “Delete Memory Map” on page 10-19
- “Share Memory Between Applications” on page 10-20

Overview of Memory-Mapping

In this section...

“What Is Memory-Mapping?” on page 10-2

“Benefits of Memory-Mapping” on page 10-2

“When to Use Memory-Mapping” on page 10-3

“Maximum Size of a Memory Map” on page 10-4

“Byte Ordering” on page 10-4

What Is Memory-Mapping?

Memory-mapping is a mechanism that maps a portion of a file, or an entire file, on disk to a range of addresses within an application's address space. The application can then access files on disk in the same way it accesses dynamic memory. This makes file reads and writes faster in comparison with using functions such as `fread` and `fwrite`.

Benefits of Memory-Mapping

The principal benefits of memory-mapping are efficiency, faster file access, the ability to share memory between applications, and more efficient coding.

Faster File Access

Accessing files via memory map is faster than using I/O functions such as `fread` and `fwrite`. Data are read and written using the virtual memory capabilities that are built in to the operating system rather than having to allocate, copy into, and then deallocate data buffers owned by the process.

MATLAB does not access data from the disk when the map is first constructed. It only reads or writes the file on disk when a specified part of the memory map is accessed, and then it only reads that specific part. This provides faster random access to the mapped data.

Efficiency

Mapping a file into memory allows access to data in the file as if that data had been read into an array in the application's address space. Initially, MATLAB only allocates address space for the array; it does not actually read data from the file until you access the mapped region. As a result, memory-mapped files provide a mechanism by which applications can access data segments in an extremely large file without having to read the entire file into memory first.

Efficient Coding Style

Memory-mapping in your MATLAB application enables you to access file data using standard MATLAB indexing operations. Once you have mapped a file to memory, you can read the contents of that file using the same type of MATLAB statements used to read variables from the MATLAB workspace. The contents of the mapped file appear as if they were an array in the currently active workspace. You simply index into this array to read or write the desired data from the file. Therefore, you do not need explicit calls to the `fread` and `fwrite` functions.

In MATLAB, if `x` is a memory-mapped variable, and `y` is the data to be written to a file, then writing to the file is as simple as

```
x.Data = y;
```

Sharing Memory Between Applications

Memory-mapped files also provide a mechanism for sharing data between applications, as shown in the figure below. This is achieved by having each application map sections of the same file. You can use this feature to transfer large data sets between MATLAB and other applications.

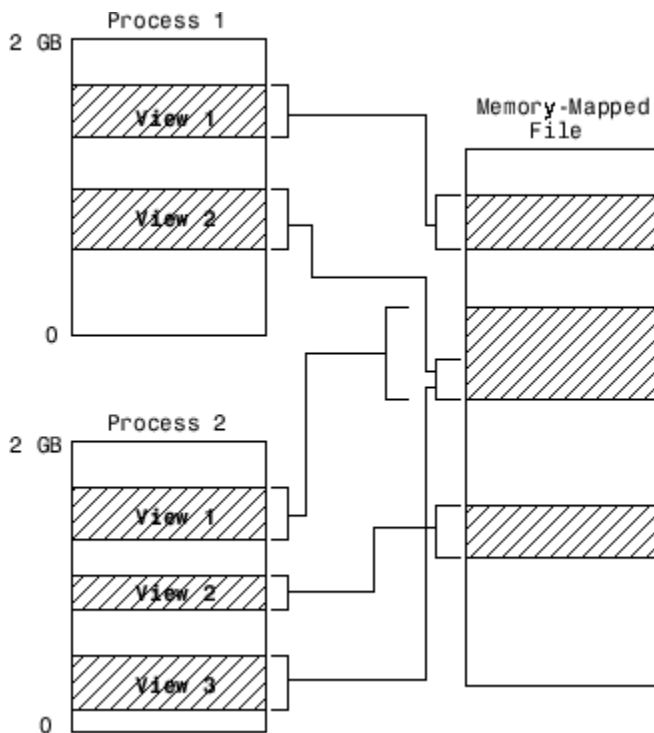

Also, within a single application, you can map the same segment of a file more than once.

When to Use Memory-Mapping

Just how much advantage you get from mapping a file to memory depends mostly on the size and format of the file, the way in which data in the file is used, and the computer platform you are using.

When Memory-Mapping Is Most Useful

Memory-mapping works best with binary files, and in the following scenarios:

- For large files that you want to access randomly one or more times
- For small files that you want to read into memory once and access frequently
- For data that you want to share between applications
- When you want to work with data in a file as if it were a MATLAB array

When the Advantage Is Less Significant

The following types of files do not fully use the benefits of memory-mapping:

- Formatted binary files like HDF or TIFF that require customized readers are not good for memory-mapping. Describing the data contained in these files can be a very complex task. Also, you cannot access data directly from the mapped segment, but must instead create arrays to hold the data.
- Text or ASCII files require that you convert the text in the mapped region to an appropriate type for the data to be meaningful. This takes up additional address space.
- Files that are larger than several hundred megabytes in size consume a significant amount of the virtual address space needed by MATLAB to process your program. Mapping files of this size may result in MATLAB reporting out-of-memory errors more often. This is more likely if MATLAB has been running for some time, or if the memory used by MATLAB becomes fragmented.

Maximum Size of a Memory Map

Due to limits set by the operating system and MATLAB, the maximum amount of data you can map with a single instance of a memory map is 2 gigabytes on 32-bit systems, and 256 terabytes on 64-bit systems. If you need to map more than this limit, you can either create separate maps for different regions of the file, or you can move the window of one map to different locations in the file.

Byte Ordering

Memory-mapping works only with data that have the same byte ordering scheme as the native byte ordering of your operating system. For example, because both Linus Torvalds' Linux and Microsoft Windows systems use little-endian byte ordering, data created on a Linux system can be read on Windows systems. You can use the `computer` function to determine the native byte ordering of your current system.

Map File to Memory

In this section...

“Create a Simple Memory Map” on page 10-5
 “Specify Format of Your Mapped Data” on page 10-6
 “Map Multiple Data Types and Arrays” on page 10-6
 “Select File to Map” on page 10-8

Create a Simple Memory Map

Suppose you want to create a memory map for a file named `records.dat`, using the `memmapfile` function.

Create a sample file named `records.dat`, containing 5000 values.

```
rng('default')
myData = rand([5000,1]);

fileID = fopen('records.dat','w');
fwrite(fileID, myData,'double');
fclose(fileID);
```

Next, create the memory map. Use the `Format` name-value pair argument to specify that the values are of type `double`. Use the `Writable` name-value pair argument to allow write access to the mapped region.

```
m = memmapfile('records.dat', ...
    'Format', 'double', ...
    'Writable', true)

m =

    Filename: 'd:\matlab\records.dat'
    Writable: true
    Offset: 0
    Format: 'double'
    Repeat: Inf
    Data: 5000x1 double array
```

MATLAB creates a `memmapfile` object, `m`. The `Format` property indicates that read and write operations to the mapped region treat the data in the file as a sequence of double-precision numbers. The `Data` property contains the 5000 values from the file, `records.dat`. You can change the value of any of the properties, except for `Data`, after you create the memory map, `m`.

For example, change the starting position of the memory map, `m`. Begin the mapped region 1024 bytes from the start of the file by changing the value of the `Offset` property.

```
m.Offset = 1024

m =

    Filename: 'd:\matlab\records.dat'
    Writable: true
    Offset: 1024
```

```

Format: 'double'
Repeat: Inf
Data: 4872x1 double array

```

Whenever you change the value of a memory map property, MATLAB remaps the file to memory. The `Data` property now contains only 4872 values.

Specify Format of Your Mapped Data

By default, MATLAB considers all the data in a mapped file to be a sequence of unsigned 8-bit integers. However, your data might be of a different data type. When you call the `memmapfile` function, use the `Format` name-value pair argument to indicate another data type. The value of `Format` can either be a character vector that identifies a single class used throughout the mapped region, or a cell array that specifies more than one class.

Suppose you map a file that is 12 kilobytes in length. Data read from this file can be treated as a sequence of 6,000 16-bit (2-byte) integers, or as 1,500 8-byte double-precision floating-point numbers, to name just a few possibilities. You also could read this data as a combination of different types: for example, as 4,000 8-bit (1-byte) integers followed by 1,000 64-bit (8-byte) integers. You can determine how MATLAB will interpret the mapped data by setting the `Format` property of the memory map when you call the `memmapfile` function.

MATLAB arrays are stored on disk in column-major order. The sequence of array elements is column 1, row 1; column 1, row 2; column 1, last row; column 2, row 1, and so on. You might need to transpose or rearrange the order of array elements when reading or writing via a memory map.

Map Multiple Data Types and Arrays

If the region you are mapping comprises segments of varying data types or array shapes, you can specify an individual format for each segment. Specify the value of the `Format` name-value pair argument as an `n`-by-3 cell array, where `n` is the number of segments. Each row in the cell array corresponds to a segment. The first cell in the row identifies the data type to apply to the mapped segment. The second cell contains the array dimensions to apply to the segment. The third cell contains the field name for referencing that segment. For a memory map, `m`, use the following syntax:

```

m = memmapfile(filename, ...
               'Format', { ...
                   datatype1, dimensions1, fieldname1; ...
                   datatype2, dimensions2, fieldname2; ...
                   :           :           :           ...
                   datatypeN, dimensionsN, fieldnameN})

```

Suppose you have a file that is 40,000 bytes in length. The following code maps the data beginning at the 2048th byte. The `Format` value is a 3-by-3 cell array that maps the file data to three different classes: `int16`, `uint32`, and `single`.

```

m = memmapfile('records.dat', ...
               'Offset', 2048, ...
               'Format', { ...
                   'int16' [2 2] 'model'; ...
                   'uint32' [1 1] 'serialno'; ...
                   'single' [1 3] 'expenses'});

```

In this case, `mmapfile` maps the `int16` data as a 2-by-2 matrix that you can access using the field name, `model`. The `uint32` data is a scalar value accessed using the field name, `serialno`. The `single` data is a 1-by-3 matrix named `expenses`. Each of these fields belongs to the 800-by-1 structure array, `m.Data`.

This figure shows the mapping of the example file.

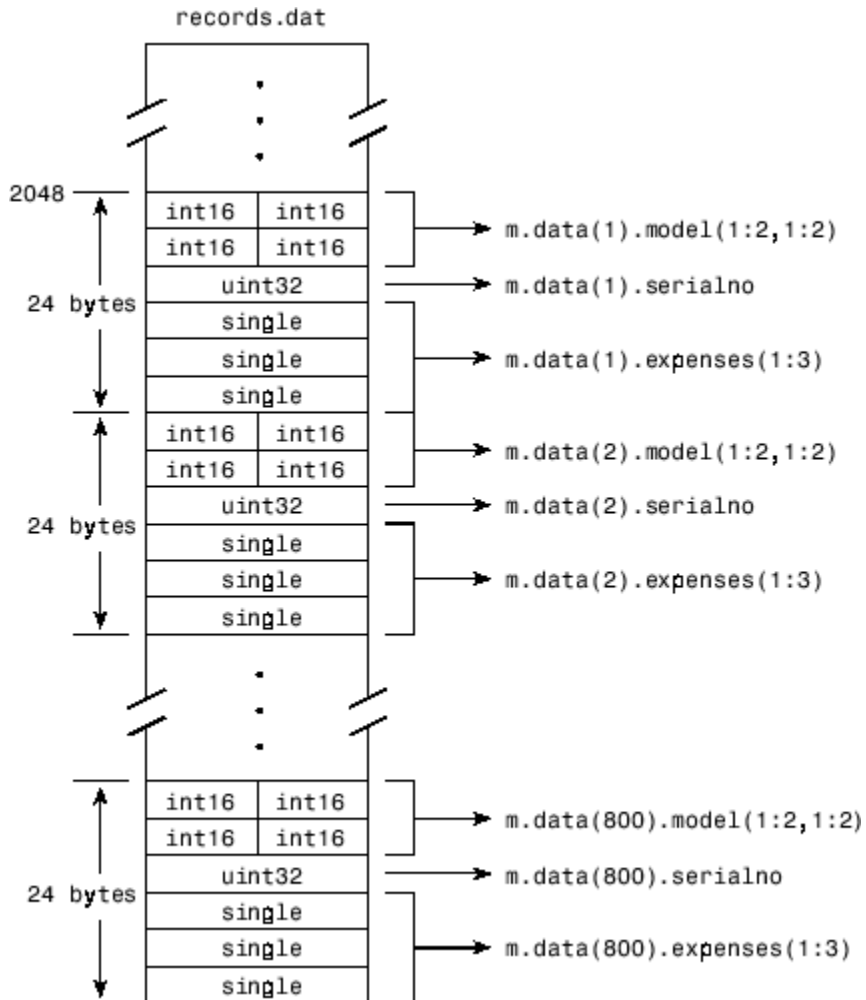

The next figure shows the ordering of the array elements more closely. In particular, it illustrates that MATLAB arrays are stored on the disk in column-major order. The sequence of array elements in the mapped file is row 1, column 1; row 2, column 1; row 1, column 2; and row 2, column 2.

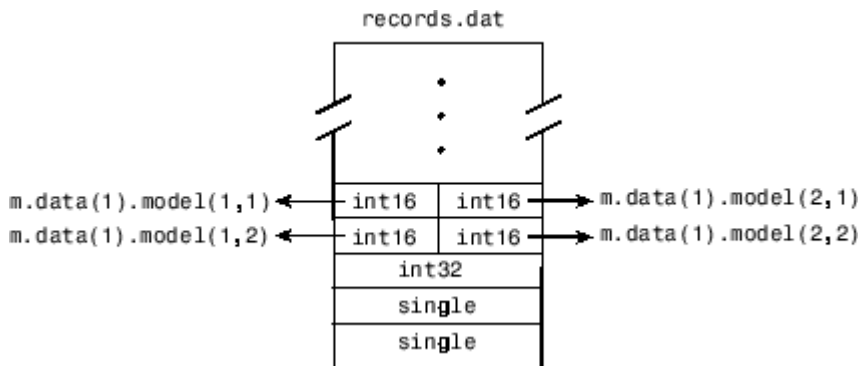

If the data in your file is not stored in this order, you might need to transpose or rearrange the order of array elements when reading or writing via a memory map.

Select File to Map

You can change the value of the `Filename` property at any time after constructing the `memmapfile` object. You might want to do this if:

- You want to use the same `memmapfile` object on more than one file.
- You save your `memmapfile` object to a MAT-file, and then later load it back into MATLAB in an environment where the mapped file has been moved to a different location. This requires that you modify the path segment of the `Filename` to represent the new location.

Update the path in the `Filename` property for a memory map using dot notation. For example, to specify a new path, `f:\testfiles\records.dat` for a memory map, `m`, type:

```
m.Filename = 'f:\testfiles\records.dat'
```

See Also

`memmapfile`

More About

- “Read from Mapped File” on page 10-9
- “Write to Mapped File” on page 10-14

Read from Mapped File

This example shows how to create two different memory maps, and then read from each of the maps using the appropriate syntax. Then, it shows how to modify map properties and analyze your data.

You can read the contents of a file that you mapped to memory using the same MATLAB® commands you use to read variables from the MATLAB workspace. By accessing the `Data` property of the memory map, the contents of the mapped file appear as an array in the currently active workspace. To read the data you want from the file, simply index into the array. For better performance, copy the `Data` field to a variable, and then read the mapped file using this variable:

```
dataRef = m.Data;

for k = 1 : N
    y(k) = dataRef(k);
end
```

By contrast, reading directly from the `memmapfile` object is slower:

```
for k = 1 : N
    y(k) = m.Data(k);
end
```

Read from Memory Map as Numeric Array

First, create a sample data file named `records.dat` that contains a 5000-by-1 matrix of double-precision floating-point numbers.

```
rng('default')
randData = rand([5000,1]);

fileID = fopen('records.dat','w');
fwrite(fileID,randData,'double');
fclose(fileID);
```

Map 100 double-precision floating-point numbers from the file to memory, and then read a portion of the mapped data. Create the memory map, `m`. Specify an `Offset` value of 1024 to begin the map 1024 bytes from the start of the file. Specify a `Repeat` value of 100 to map 100 values.

```
m = memmapfile('records.dat','Format','double', ...
    'Offset',1024,'Repeat',100);
```

Copy the `Data` property to a variable, `d`. Then, show the format of `d`.

```
d = m.Data;
```

```
whos d
```

Name	Size	Bytes	Class	Attributes
d	100x1	800	double	

The mapped data is an 800-byte array because there are 100 `double` values, each requiring 8 bytes.

Read a selected set of numbers from the file by indexing into the vector, `d`.

```
d(15:20)
ans = 6×1
    0.3510
    0.5132
    0.4018
    0.0760
    0.2399
    0.1233
```

Read from Memory Map as Nonscalar Structure

Map portions of data in the file, `records.dat`, as a sequence of multiple data types.

Call the `memmapfile` function to create a memory map, `m`.

```
m = memmapfile('records.dat', ...
    'Format', {
        'uint16' [5 8] 'x'; ...
        'double' [4 5] 'y' });
```

The `Format` parameter tells `memmapfile` to treat the first 80 bytes of the file as a 5-by-8 matrix of `uint16` values, and the 160 bytes after that as a 4-by-5 matrix of `double` values. This pattern repeats until the end of the file is reached.

Copy the `Data` property to a variable, `d`.

```
d = m.Data
d=166×1 struct array with fields:
    x
    y
```

`d` is a 166-element structure array with two fields. `d` is a nonscalar structure array because the file is mapped as a repeating sequence of multiple data types.

Examine one structure in the array to show the format of each field.

```
d(3)
ans = struct with fields:
    x: [5x8 uint16]
    y: [4x5 double]
```

Read the `x` field of that structure from the file.

```
d(3).x
ans = 5x8 uint16 matrix
    62645    30353    12492    16358    58958    9377    48754    16323
```

```

14152  21370  16352  21042  61010  33482  16321  22042
 2657  16336  37389  35249  45699  16353  47136  59002
16360  41668   9638  33351  16366   3344  58286  31491
 5368  55234  24278  16364  55768   7216   7184  16336

```

MATLAB formats the block of data as a 5-by-8 matrix of `uint16` values, as specified by the `Format` property.

Read the `y` field of that structure from the file.

```
d(3).y
```

```
ans = 4x5
```

```

 0.8407  0.9293  0.6160  0.5853  0.7572
 0.2543  0.3500  0.4733  0.5497  0.7537
 0.8143  0.1966  0.3517  0.9172  0.3804
 0.2435  0.2511  0.8308  0.2858  0.5678

```

MATLAB formats the block of data as a 4-by-5 matrix of `double` values.

Modify Map Properties and Analyze Data

This part of the example shows how to plot the Fourier transform of data read from a file via a memory map. It then modifies several properties of the existing map, reads from a different part of the data file, and plots a histogram from that data.

Create a sample file named `double.dat`.

```

randData = rand([5000,1]);
fileID = fopen('double.dat','w');
fwrite(fileID,randData,'double');
fclose(fileID);

```

Create a `memmapfile` object of 1,000 elements of type `double`, starting at the 1025th byte.

```

m = memmapfile('double.dat','Offset',1024, ...
    'Format','double','Repeat',1000);

```

Copy the `Data` property to a variable, `k`. Then, get data associated with the map and plot the FFT of the first 100 values of the map.

```

k = m.Data;
plot(abs(fft(k(1:100))))

```

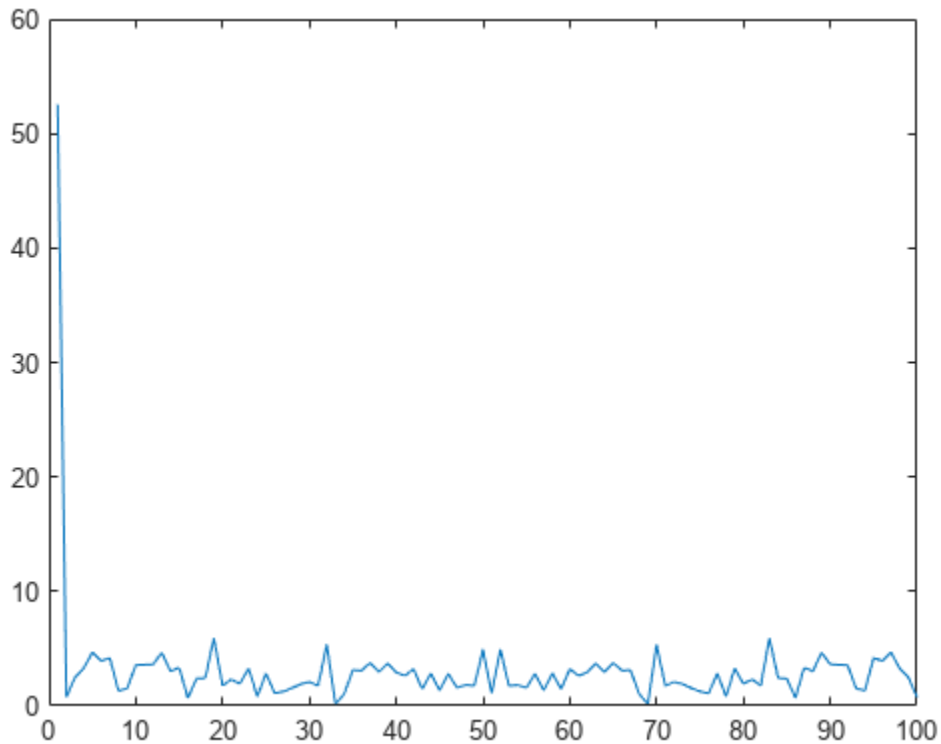

This is the first time that data is referenced and is when the actual mapping of the file to the MATLAB address space takes place.

Change the map properties, but continue using the same file. Whenever you change the value of a memory map property, MATLAB remaps the file to memory.

```
m.Offset = 4096;  
m.Format = 'single';  
m.Repeat = 800;
```

`m` is now a `memmapfile` object of 800 elements of type `single`. The map now begins at the 4096th byte in the file, `records.dat`.

Read from the portion of the file that begins at the 4096th byte, and calculate the maximum value of the data. This command maps a new region and unmaps the previous region.

```
X = max(m.Data)
```

```
X = single  
    3.2278e+38
```

See Also

`memmapfile`

More About

- “Map File to Memory” on page 10-5
- “Write to Mapped File” on page 10-14

Write to Mapped File

This example shows how to create three different memory maps, and then write to each of the maps using the appropriate syntax. Then, it shows how to work with copies of your mapped data.

You can write to a file using the same MATLAB commands you use to access variables in the MATLAB workspace. By accessing the `Data` property of the memory map, the contents of the mapped file appear as an array in the currently active workspace. Simply index into this array to write data to the file. The syntax to use when writing to mapped memory depends on the format of the `Data` property of the memory map.

In this section...

“Write to Memory Mapped as Numeric Array” on page 10-14

“Write to Memory Mapped as Scalar Structure” on page 10-15

“Write to Memory Mapped as Nonscalar Structure” on page 10-15

“Syntaxes for Writing to Mapped File” on page 10-16

“Work with Copies of Your Mapped Data” on page 10-17

Write to Memory Mapped as Numeric Array

First, create a sample file named `records.dat`, in your current folder.

```
rng('default')
myData = rand([5000,1]);

fileID = fopen('records.dat','w');
fwrite(fileID, myData, 'double');
fclose(fileID);
```

Map the file as a sequence of 16-bit-unsigned integers. Use the `Format` name-value pair argument to specify that the values are of type `uint16`.

```
m = memmapfile('records.dat', ...
    'Offset',20, ...
    'Format','uint16', ...
    'Repeat',15);
```

Because the file is mapped as a sequence of a single class (`uint16`), `Data` is a numeric array.

Ensure that you have write permission to the mapped file. Set the `Writable` property of the memory map, `m`, to `true`.

```
m.Writable = true;
```

Create a matrix `X` that is the same size as the `Data` property, and write it to the mapped part of the file. All of the usual MATLAB indexing and class rules apply when assigning values to data via a memory map. The class that you assign to must be big enough to hold the value being assigned.

```
X = uint16(1:1:15);
m.Data = X;
```

`X` is a 1-by-15 vector of integer values ranging from 1 to 15.

Verify that new values were written to the file. Specify an `Offset` value of 0 to begin reading from the beginning of the file. Specify a `Repeat` value of 35 to view a total of 35 values. Use the `reshape` function to display the values as a 7-by-5 matrix.

```
m.Offset = 0;
m.Repeat = 35;
reshape(m.Data,5,7)'
```

```
ans = 7x5 uint16 matrix
```

```
 47739   26762    4663   16362    3197
 24407   64575   16364   31612   40832
     1         2         3         4         5
     6         7         8         9        10
    11        12        13        14        15
 12673   53994   16337   46560   44024
 32781   16353   24667   24572   41957
```

The values in `X` have been written to the file, `records.dat`.

Write to Memory Mapped as Scalar Structure

Map a region of the file, `records.dat`, as a 300-by-8 matrix of type `uint16` that can be referenced by the field name, `x`, followed by a 200-by-5 matrix of type `double` that can be reference by the field name, `y`. Specify write permission to the mapped file using the `Writable` name-value pair argument.

```
m = memmapfile('records.dat', ...
    'Format', { ...
        'uint16' [300 8] 'x'; ...
        'double' [200 5] 'y' }, ...
    'Repeat', 1, 'Writable', true);
```

View the `Data` property

```
m.Data
```

```
ans = struct with fields:
    x: [300x8 uint16]
    y: [200x5 double]
```

`Data` is a scalar structure array. This is because the file, `records.dat`, is mapped as containing multiple data types that do not repeat.

Replace the matrix in the field, `x`, with a matrix of all ones.

```
m.Data.x = ones(300,8,'uint16');
```

Write to Memory Mapped as Nonscalar Structure

Map the file, `records.dat`, as a 25-by-8 matrix of type `uint16` followed by a 15-by-5 matrix of type `double`. Repeat the pattern 20 times.

```
m = memmapfile('records.dat', ...
    'Format', { ...
```

```
'uint16' [5 4] 'x'; ...
'double' [15 5] 'y' }, ...
'Repeat', 20, 'Writable', true);
```

View the Data property

```
m.Data
```

```
ans=20x1 struct array with fields:
    x
    y
```

Data is a nonscalar structure array, because the file is mapped as a repeating sequence of multiple data types.

Write an array of all ones to the field named x in the 12th element of Data.

```
m.Data(12).x = ones(5,4,'uint16');
```

For the 12th element of Data, write the value, 50, to all elements in rows 3 to 5 of the field, x.

```
m.Data(12).x(3:5,1:end) = 50;
```

View the field, x, of the 12th element of Data.

```
m.Data(12).x
ans = 5x4 uint16 matrix
```

```
 1   1   1   1
 1   1   1   1
50  50  50  50
50  50  50  50
50  50  50  50
```

Syntaxes for Writing to Mapped File

The syntax to use when writing to mapped memory depends on the format of the Data property of the memory map. View the properties of the memory map by typing the name of the memmapfile object.

This table shows the syntaxes for writing a matrix, X, to a memory map, m.

Format of the Data Property	Syntax for Writing to Mapped File
Numeric array Example: 15x1 uint16 array	m.Data = X;
Scalar (1-by-1) structure array Example: 1x1 struct array with fields: x y	m.Data.fieldname = X; <i>fieldname</i> is the name of a field.

Format of the Data Property	Syntax for Writing to Mapped File
Nonscalar (n-by-1) structure array	<code>m.Data(k).fieldname = X;</code>
Example: 20x1 struct array with fields: x y	k is a scalar index and <i>fieldname</i> is the name of a field.

The class of *X* and the number of elements in *X* must match those of the `Data` property or the field of the `Data` property being accessed. You cannot change the dimensions of the `Data` property after you have created the memory map using the `memmapfile` function. For example, you cannot diminish or expand the size of an array by removing or adding a row from the mapped array, `m.Data`.

If you map an entire file and then append to that file after constructing the map, the appended data is not included in the mapped region. If you need to modify the dimensions of data that you have mapped to a memory map, `m`, you must either modify the `Format` or `Repeat` properties for `m`, or recreate `m` using the `memmapfile` function.

Note To successfully modify a mapped file, you must have write permission for that file. If you do not have write permission, attempting to write to the file generates an error, even if the `Writable` property is `true`.

Work with Copies of Your Mapped Data

This part of the example shows how to work with copies of your mapped data. The data in variable `d` is a copy of the file data mapped by `m.Data(2)`. Because it is a copy, modifying array data in `d` does not modify the data contained in the file.

Create a sample file named `double.dat`.

```
myData = rand([5000,1])*100;
fileID = fopen('double.dat','w');
fwrite(fileID,myData,'double');
fclose(fileID);
```

Map the file as a series of `double` matrices.

```
m = memmapfile('double.dat', ...
    'Format', { ...
    'double' [5 5] 'x'; ...
    'double' [4 5] 'y' });
```

View the values in `m.Data(2).x`.

```
m.Data(2).x
```

```
ans = 5x5
```

```
95.0545  54.7696  15.6697  97.2605  85.0706
53.2131  60.9054   5.8124  60.5319  25.6792
24.7686  86.3135  33.9707  33.8236  28.5496
43.7276  38.0696  81.7176  92.7984  77.9947
66.9088  74.8956  37.7548  89.8425  70.1395
```

Copy the contents of `m.Data` to the variable, `d`.

```
d = m.Data;
```

Write all zeros to the field named `x` in the copy.

```
d(2).x(1:5,1:5) = 0;
```

Verify that zeros are written to `d(2).x`

```
d(2).x
```

```
ans = 5×5
```

```
0     0     0     0     0
0     0     0     0     0
0     0     0     0     0
0     0     0     0     0
0     0     0     0     0
```

Verify that the data in the mapped file is not changed.

```
m.Data(2).x
```

```
ans = 5×5
```

```
95.0545  54.7696  15.6697  97.2605  85.0706
53.2131  60.9054   5.8124  60.5319  25.6792
24.7686  86.3135  33.9707  33.8236  28.5496
43.7276  38.0696  81.7176  92.7984  77.9947
66.9088  74.8956  37.7548  89.8425  70.1395
```

See Also

`memmapfile`

More About

- “Map File to Memory” on page 10-5
- “Read from Mapped File” on page 10-9

Delete Memory Map

In this section...
“Ways to Delete a Memory Map” on page 10-19
“The Effect of Shared Data Copies On Performance” on page 10-19

Ways to Delete a Memory Map

To clear a `memmapfile` object from memory, do any of the following:

- Reassign another value to the `memmapfile` object's variable
- Clear the `memmapfile` object's variable from memory
- Exit the function scope in which the `memmapfile` object was created

The Effect of Shared Data Copies On Performance

When you assign the `Data` field of the `memmapfile` object to a variable, MATLAB makes a shared data copy of the mapped data. This is very efficient because no memory actually gets copied. In the following statement, `d` is a shared data copy of the data mapped from the file:

```
d = m.Data;
```

When you finish using the mapped data, make sure to clear any variables that share data with the mapped file before clearing the `memmapfile` object itself. If you clear the object first, then the sharing of data between the file and dependent variables is broken, and the data assigned to such variables must be copied into memory before the object is cleared. If access to the mapped file was over a network, then copying this data to local memory can take considerable time. Therefore, if you assign `m.Data` to the variable, `d`, you should be sure to clear `d` before clearing `m` when you are finished with the memory map.

Share Memory Between Applications

This example shows how to implement two separate MATLAB processes that communicate with each other by writing and reading from a shared file. They share the file by mapping part of their memory space to a common location in the file. A write operation to the memory map belonging to the first process can be read from the map belonging to the second, and vice versa.

One MATLAB process (running `send.m`) writes a message to the file via its memory map. It also writes the length of the message to byte 1 in the file, which serves as a means of notifying the other process that a message is available. The second process (running `answer.m`) monitors byte 1 and, upon seeing it set, displays the received message, puts it into uppercase, and echoes the message back to the sender.

Prior to running the example, copy the `send` and `answer` functions to files `send.m` and `answer.m` in your current working directory.

The `send` Function

This function prompts you to enter text and then, using memory-mapping, passes the text to another instance of MATLAB that is running the `answer` function.

```
function send
% Interactively send a message to ANSWER using memmapfile class.

filename = fullfile(tempdir, 'talk_answer.dat');

% Create the communications file if it is not already there.
if ~exist(filename, 'file')
    [f, msg] = fopen(filename, 'wb');
    if f ~= -1
        fwrite(f, zeros(1,256), 'uint8');
        fclose(f);
    else
        error('MATLAB:demo:send:cannotOpenFile', ...
            'Cannot open file "%s": %s.', filename, msg);
    end
end

% Memory map the file.
m = memmapfile(filename, 'Writable', true, 'Format', 'uint8');

while true
    % Set first byte to zero, indicating a message is not
    % yet ready.
    m.Data(1) = 0;

    str = input('Enter text (or RETURN to end): ', 's');

    len = length(str);
    if (len == 0)
        disp('Terminating SEND function.')
        break;
    end

    % Warn if the message is longer than 255 characters.
    if len > 255
```



```

        warning('ml:ml', 'SEND input will be truncated to 255 characters.');
```

end

```

str = str(1:min(len,255)); % Limit message to 255 characters.
len = length(str); % Update len if str has been truncated.

% Update the file via the memory map.
m.Data(2:len+1) = str;
m.Data(1)=len;

% Wait until the first byte is set back to zero,
% indicating that a response is available.
while (m.Data(1) ~= 0)
    pause(.25);
end

% Display the response.
disp('response from ANSWER is:')
disp(char(m.Data(2:len+1)))

end
```

The answer Function

The answer function starts a server that, using memory-mapping, watches for a message from send. When the message is received, answer replaces the message with an uppercase version of it, and sends this new message back to send. To use answer, call it with no inputs.

```

function answer
% Respond to SEND using memmapfile class.

disp('ANSWER server is awaiting message');

filename = fullfile(tempdir, 'talk_answer.dat');

% Create the communications file if it is not already there.
if ~exist(filename, 'file')
    [f, msg] = fopen(filename, 'wb');
    if f ~= -1
        fwrite(f, zeros(1,256), 'uint8');
        fclose(f);
    else
        error('MATLAB:demo:answer:cannotOpenFile', ...
            'Cannot open file "%s": %s.', filename, msg);
    end
end

% Memory map the file.
m = memmapfile(filename, 'Writable', true, 'Format', 'uint8');

while true
    % Wait until the first byte is not zero.
    while m.Data(1) == 0
        pause(.25);
    end

    % The first byte now contains the length of the message.
    % Get it from m.
```

```
msg = char(m.Data(2:1+double(m.Data(1))))';  
  
% Display the message.  
disp('Received message from SEND:')  
disp(msg)  
  
% Transform the message to all uppercase.  
m.Data(2:1+double(m.Data(1))) = upper(msg);  
  
% Signal to SEND that the response is ready.  
m.Data(1) = 0;  
end
```

Running the Example

To see what the example looks like when it is run, first, start two separate MATLAB sessions on the same computer system. Call the `send` function with no inputs in one MATLAB session. Call the `answer` function in the other session, to create a map in each of the processes' memory to the common file.

Run `send` in the first MATLAB session.

```
send
```

```
Enter text (or RETURN to end):
```

Run `answer` in the second MATLAB session.

```
answer
```

```
ANSWER server is awaiting message
```

Next, enter a message at the prompt displayed by the `send` function. MATLAB writes the message to the shared file. The second MATLAB session, running the `answer` function, loops on byte 1 of the shared file and, when the byte is written by `send`, `answer` reads the message from the file via its memory map. The `answer` function then puts the message into uppercase and writes it back to the file, and `send` (waiting for a reply) reads the message and displays it.

`send` writes a message and reads the uppercase reply.

```
Hello. Is there anybody out there?
```

```
response from ANSWER is:  
HELLO. IS THERE ANYBODY OUT THERE?  
Enter text (or RETURN to end):
```

`answer` reads the message from `send`.

```
Received message from SEND:  
Hello. Is there anybody out there?
```

Enter a second message at the prompt display by the `send` function. `send` writes the second message to the file.

```
I received your reply.
```

```
response from ANSWER is:  
I RECEIVED YOUR REPLY.  
Enter text (or RETURN to end):
```

`answer` reads the second message, put it into uppercase, and then writes the message to the file.

```
Received message from SEND:  
I received your reply.
```

In the first instance of MATLAB, press **Enter** to exit the example.

```
Terminating SEND function.
```

Internet File Access and JSON

Server Authentication

MATLAB provides programmatic interfaces to these Web service interfaces.

- RESTful (Representational state transfer)—Use the `webread`, `webwrite`, and `websave` functions in “Web Services” to read content from RESTful Web services.
- HTTP (Hypertext Transfer Protocol)—Use the “Use HTTP with MATLAB” API to implement advanced HTTP messaging semantics.

To use a proxy server, see “Proxy Server Authentication” on page 11-4.

Server Authentication For RESTful Web Services

Kerberos is not supported on Linux and macOS platforms.

Authentication	Platform	weboptions	weboptions Arguments	System Setup
Basic	Windows Linux macOS	Required	Username and Password	N/A
Digest	Windows Linux macOS	Required	Username and Password	N/A
NTLM	Windows	Optional	Do not specify Username or Password	Logged into Windows domain
NTLM	Linux macOS	Required	Username and Password	N/A
Kerberos Negotiate (SPNEGO)	Windows	Optional	Do not specify Username or Password	Logged into Kerberos domain

Server Authentication For HTTP Web Services

Kerberos is not supported on Linux and macOS platforms.

Server Authentication	Platform	matlab.net.http HTTPOptions Object	matlab.net.http Credentials Properties	System Setup
Basic Digest	Windows Linux macOS	Credentials property	Username and Password	N/A
NTLM	Windows	Credentials property	Username and Password ignored	Logged into Windows domain
NTLM	Linux macOS	Credentials property	Username and Password	N/A

Server Authentication	Platform	matlab.net.http HTTPOptions Object	matlab.net.http Credentials Properties	System Setup
Kerberos Negotiate (SPNEGO)	Windows	Credentials property	Username and Password ignored	Logged into Kerberos domain

See Also

[matlab.net.http.AuthenticationScheme](#) | [matlab.net.http.HTTPOptions](#) | [matlab.net.http.Credentials](#)

More About

- “Proxy Server Authentication” on page 11-4
- “Web Services”
- “Use HTTP with MATLAB”

Proxy Server Authentication

MATLAB provides programmatic interfaces to these Web service interfaces.

- RESTful (Representational state transfer)—Use the `webread`, `webwrite`, and `websave` functions in “Web Services” to read content from RESTful Web services.
- HTTP (Hypertext Transfer Protocol)—Use the “Use HTTP with MATLAB” API to implement advanced HTTP messaging semantics.

To authenticate to a server, see “Server Authentication” on page 11-2.

RESTful Web Services

MATLAB supports Basic, Digest, and NTLM proxy authentication types. On Windows platforms, MATLAB also supports Kerberos. To specify proxy server settings, choose one of these:

- 1 “Use MATLAB Web Preferences For Proxy Server Settings” on page 11-4
- 2 “Use System Settings For Proxy Server Settings” on page 11-5

If you specify the values using Web preferences, then MATLAB ignores system settings.

HTTP Web Services

MATLAB supports Basic, Digest, and NTLM proxy authentication types. On Windows platforms, MATLAB also supports Kerberos. To specify proxy server settings, choose one of these:

- 1 If you specify a `ProxyURI` in a `matlab.net.http.HTTPOptions` object, then set the `Username` and `Password` properties in `matlab.net.http.Credentials`.
- 2 “Use MATLAB Web Preferences For Proxy Server Settings” on page 11-4
- 3 “Use System Settings For Proxy Server Settings” on page 11-5

MATLAB chooses the first setting in this list.

Use MATLAB Web Preferences For Proxy Server Settings

You can specify proxy server settings using MATLAB “Web Preferences”.

Note Settings in Web Preferences override system settings.

To specify the proxy server settings:

- 1 On the **Home** tab, in the **Environment** section, click  **Preferences**. Select **MATLAB > Web**.
- 2 Select the **Use a proxy server to connect to the Internet** check box.
- 3 Specify values for **Proxy host** and **Proxy port**.

Examples of acceptable formats for the host are: `172.16.10.8` and `ourproxy`. For the port, enter an integer only, such as `22`. If you do not know the values for your proxy server, ask your system or network administrator for the information.

If your proxy server requires a user name and password, select the **Use a proxy with authentication** check box. Then enter your proxy user name and password.

- 4 Ensure that your settings work by clicking the **Test connection** button.

MATLAB attempts to connect to `https://www.mathworks.com`:

- If MATLAB can access the Internet, **Success!** appears next to the button.
 - If MATLAB cannot access the Internet, **Failed!** appears next to the button. Correct the values you entered and try again. If you still cannot connect, try using the values you used when you authenticated your MATLAB license.
- 5 Click **OK** to accept the changes.
 - 6 Restart MATLAB to enable the changes.

Use System Settings For Proxy Server Settings

If no proxy is specified in MATLAB Web preferences, then MATLAB uses the proxy set in the operating system preferences.

Operating System	System Proxy Settings
Windows	Network & Internet section of Settings
macOS	Network section of System Preferences
Linux	Environment variables <code>http_proxy</code> and <code>https_proxy</code>

To specify proxy server settings in system preferences, refer to your Windows, Linux, or macOS operating system documentation.

MATLAB does not take into account proxy exceptions which you configure in Windows.

See Also

`matlab.net.http.HTTPOptions` | `matlab.net.http.Credentials`

More About

- “Server Authentication” on page 11-2
- “Web Services”
- “Use HTTP with MATLAB”

MATLAB and Web Services Security

This topic describes how MATLAB handles security for web services. For a complete description of computer security, you need to consult external resources.

MATLAB Does Not Verify Certificate Chains

For HTTPS connections, the `webread`, `webwrite`, and `websave` functions verify that the certificate domain matches the host name of the web service. These functions do not verify the certificate chain. For a complete description of computer security, you need to consult external resources.

See Also

`webread` | `webwrite` | `websave`

Download Data from Web Service

This example shows how to download data from a web service with the `webread` function. The World Bank provides various climate data via the World Bank Climate Data API. A call to this API returns data in JSON format. `webread` converts JSON objects to structures that are convenient for analysis in MATLAB.

Use `webread` to read USA average annual temperatures into a structure array.

```
api = 'http://climatedataapi.worldbank.org/climateweb/rest/v1/';
url = [api 'country/cru/tas/year/USA'];
S = webread(url)
```

```
S =
```

```
112x1 struct array with fields:
```

```
    year
    data
```

`webread` converted the data to a structure array with 112 elements. Each structure contains the temperature for a given year, from 1901 to 2012.

```
S(1)
```

```
ans =
```

```
    year: 1901
    data: 6.6187
```

```
S(112)
```

```
ans =
```

```
    year: 2012
    data: 7.9395
```

Plot the average temperature per year. Convert the temperatures and years to numeric arrays. Convert the years to a datetime object for ease of plotting, and convert the temperatures to degrees Fahrenheit.

```
temps = [S.data];
temps = 9/5 * temps + 32;
years = [S.year];
yearstoplot = datetime(years,1,1);
figure
plot(yearstoplot, temps);
title('USA Average Temperature 1901-2012')
xlabel('Year')
ylabel('Temperature (^{\circ}F)')
xmin = datetime(1899,1,1);
xmax = datetime(2014,1,1);
xlim([xmin xmax])
```

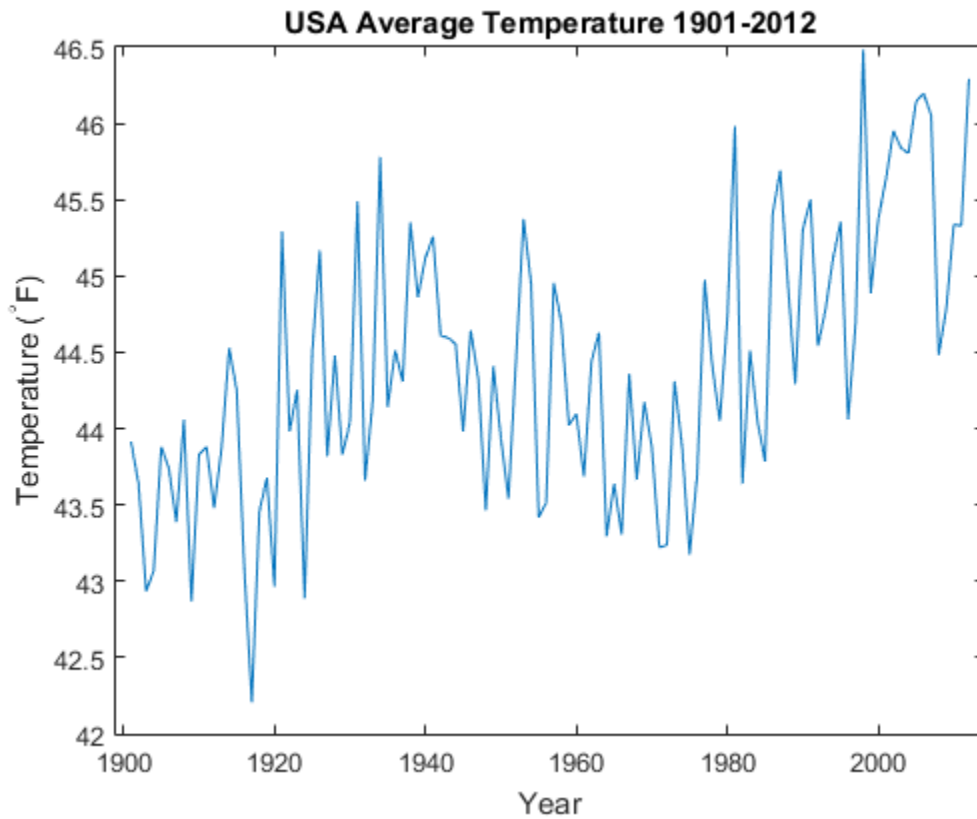

Overplot a least-squares fit of a line to the temperatures.

```
p = polyfit(years,temps,1);
ptemps = polyval(p,years);
deltat = p(1);
hold on
fl = plot(yearstoplot, ptemps);
xlim([xmin xmax])
title('USA Average Temperature Trend 1901-2012')
xlabel('Year')
ylabel('Temperature (°F)')
deltat = num2str(10.0*deltat);
legend(fl,['Least Squares Fit, ', deltat, '°F/decade'])
hold off
```

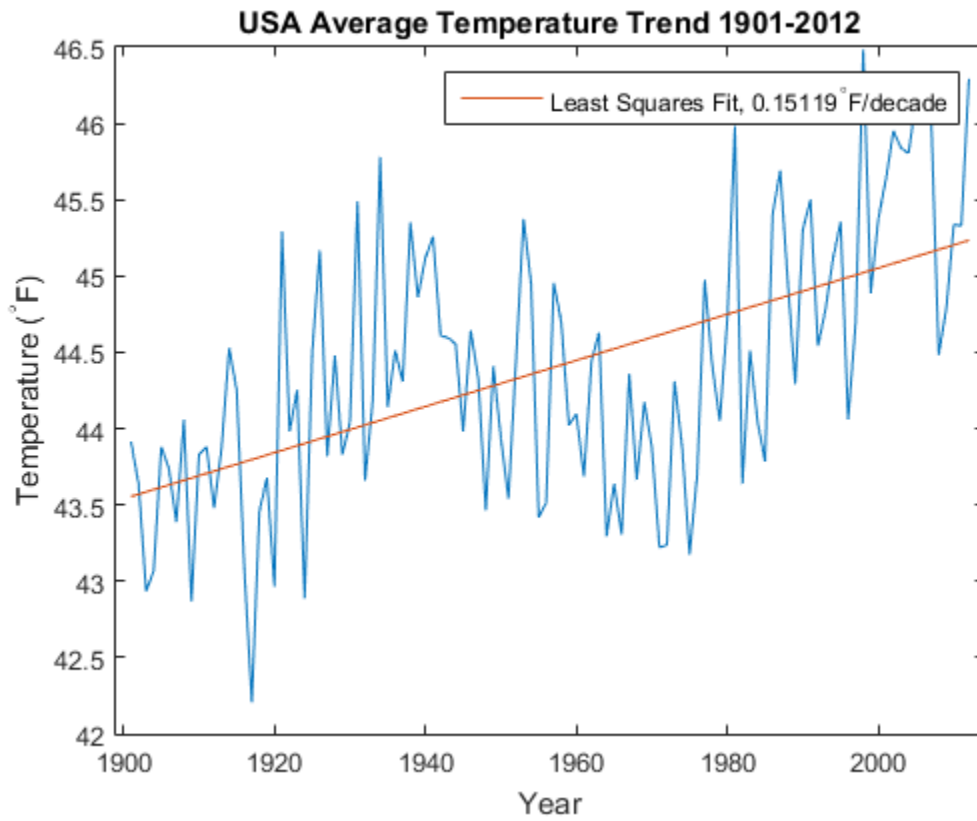

API and data courtesy of the World Bank: Climate Data API. (See World Bank: Climate Data API for more information about the API, and World Bank: Terms of Use.)

Convert Data from Web Service

This example shows how to download data from a web service and use a function as a content reader with `webread`.

The National Geophysical Data Center (NGDC) provides various geophysical and space weather data via a web service. Among other data sets, the NGDC aggregates sunspot numbers published by the American Association of Variable Star Observers (AAVSO). Use `webread` to download sunspot numbers for every year since 1945.

```
api = 'http://www.ngdc.noaa.gov/stp/space-weather/';
url = [api 'solar-data/solar-indices/sunspot-numbers/' ...
      'american/lists/list_aavso-arssn_yearly.txt'];
spots = webread(url);
whos('spots')
```

Name	Size	Bytes	Class	Attributes
spots	1x1269	2538	char	

The NGDC web service returns the sunspot data as text. By default, `webread` returns the data as a character array.

```
spots(1:100)
```

```
ans =
```

```

      American
Year   SSN
1945   32.3
1946   99.9
1947  170.9
1948  166.6
```

`webread` can use a function to return the data as a different type. You can use `readtable` with `webread` to return the sunspot data as a table.

Create a `weboptions` object that specifies a function for `readtable`.

```
myreadtable = @(filename)readtable(filename,'HeaderLines',1, ...
    'Format','%f%f','Delimiter','space','MultipleDelimsAsOne',1);
options = weboptions('ContentReader',myreadtable);
```

For this data, call `readtable` with several `Name`, `Value` input arguments to convert the data. For example, `Format` indicates that each row has two numbers. Spaces are delimiters, and multiple consecutive spaces are treated as a single delimiter. To call `readtable` with these input arguments, wrap `readtable` and the arguments in a new function, `myreadtable`. Create a `weboptions` object with `myreadtable` as the content reader.

Download sunspot data and return the data as a table.

```
spots = webread(url,options);
whos('spots')
```

Name	Size	Bytes	Class	Attributes
spots	76x2	2932	table	

Display the sunspot data by column and row.

```
spots(1:4,{'Year', 'SSN'})
```

```
ans =
```

Year	SSN
1945	32.3
1946	99.9
1947	170.9
1948	166.6

Plot sunspot numbers by year. Use table functions to select sunspot numbers up to the year 2013. Convert the Year and SSN columns to arrays and plot them.

```
rows = spots.Year < 2014;  
vars = {'Year', 'SSN'};  
spots = spots(rows,vars);  
year = spots.Year;  
numspots = spots.SSN;  
figure  
plot(year,numspots);  
title('Sunspot Data');  
xlabel('Year');  
ylabel('Number of Sunspots');  
xlim([1940 2015])  
ylim([0 180])
```

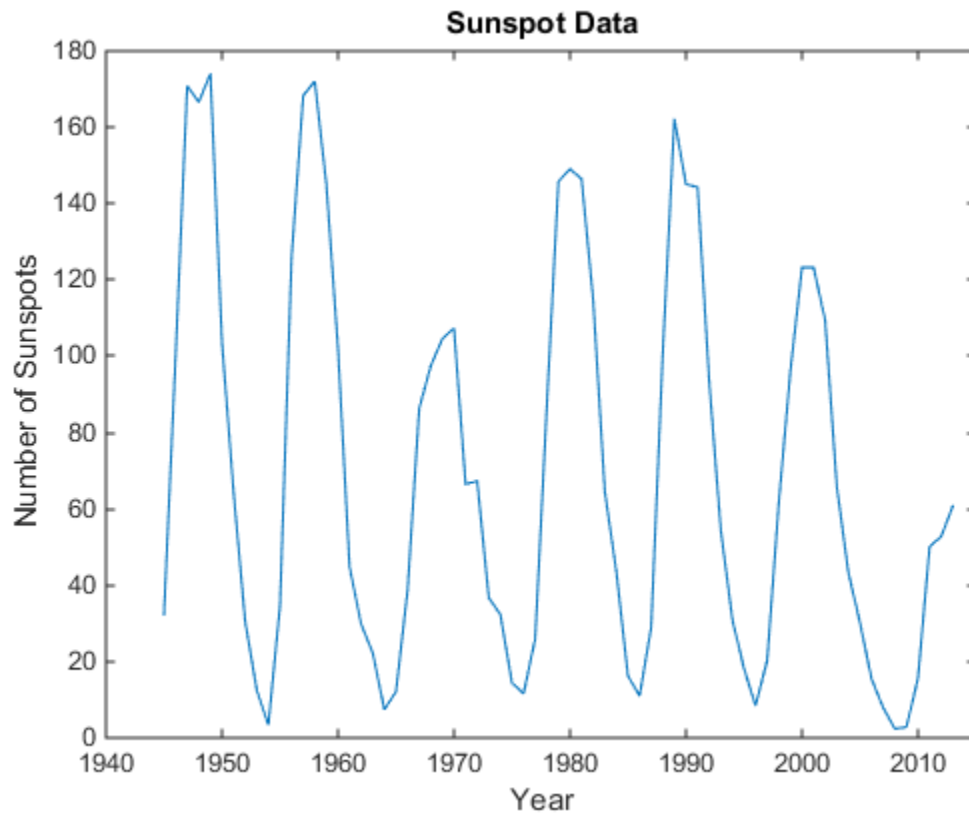

Aggregated data and web service courtesy of the NGDC. Sunspot data courtesy of the AAVSO, originally published in AAVSO Sunspot Counts: 1943-2013, AAVSO Solar Section (R. Howe, Chair).

- See NGDC Privacy Policy, Disclaimer, and Copyright for NGDC terms of service.
- See AAVSO Solar Section for more information on AAVSO solar data, including terms of use.

Download Web Page and Files

MATLAB provides two functions for reading content from RESTful web services: `webread` and `websave`. With the `webread` function, you can read the contents of a web page to a character array in the MATLAB workspace. With the `websave` function, you can save web page content to a file.

Because it can create a character array in the workspace, the `webread` function is useful for working with the contents of web pages in MATLAB. The `websave` function is useful for saving web pages to a local folder.

Note When `webread` returns HTML as a character array, remember that only the HTML in that specific web page is retrieved. The hyperlink targets, images, and so on, are not retrieved.

If you need to pass parameters to a web page, the `webread` and `websave` functions let you define the parameters as `Name, Value` pair arguments. For more information, see the `webread` and `websave` reference pages.

Example — Use the `webread` Function

The following procedure demonstrates how to retrieve the contents of the web page listing the files submitted to the MATLAB Central™ File Exchange, <https://www.mathworks.com/matlabcentral/fileexchange/>. It assigns the results to a character array, `fullList`:

```
filex = 'https://www.mathworks.com/matlabcentral/fileexchange/';
fullList = webread(filex);
```

Retrieve a list of only those files uploaded to the File Exchange within the past seven days that contain the word Simulink®. Set `duration` and `term` as parameters that `webread` passes to the web page.

```
filex = 'https://www.mathworks.com/matlabcentral/fileexchange/';
recent = webread(filex,'duration',7,'term','simulink');
```

Example — Use the `websave` Function

The following example builds on the procedure in the previous section, but saves the content to a file:

```
% Locate the list of files at the MATLAB Central File Exchange
% uploaded within the past 7 days, that contain "Simulink."
filex = 'https://www.mathworks.com/matlabcentral/fileexchange/';

% Save the Web content to a file.
recent = websave('contains_simulink.html',filex, ...
    'duration',7,'term','simulink');
```

MATLAB saves the web page as `contains_simulink.html`. The output argument `recent` contains the full path to `contains_simulink.html`. Call the web function to display `contains_simulink.html` in a browser.

```
web(recent)
```

This page has links to files uploaded to the MATLAB Central File Exchange.

Call Web Services from Functions

You can call `webread` from functions you define. Best practice is to allow your function to pass HTTP request options to `webread`.

This code sample shows how to download climate data for a country. The sample defines a function in a file named `worldBankTemps.m` that downloads annual temperatures from the World Bank and converts them to degrees Fahrenheit. You can pass additional HTTP request parameters with the `options` input argument. `options` is a `weboptions` object that `worldBankTemps` passes to `webread`. You can call `worldBankTemps` with a country name only when you do not need to define any other HTTP request parameters.

```
function temperatures = worldBankTemps(country,options)
% Get World Bank temperatures for a country, for example, 'USA'.
api = 'http://climatedataapi.worldbank.org/climateweb/rest/v1/';
api = [api 'country/cru/tas/year/'];
country = [api country];

% The options object contains additional HTTP
% request parameters. If worldBankTemps was
% not passed options as an input argument,
% create a default weboptions object.
if ~exist('options','var')
    options = weboptions;
end
s = webread(country,options);

% Convert data to arrays
temperatures = struct('Years',[],'DegreesInFahrenheit',[]);
temperatures(1).Years = [s.year];
temperatures(1).DegreesInFahrenheit = [s.data];

% Convert temperatures to Fahrenheit
temperatures(1).DegreesInFahrenheit = temperatures(1).DegreesInFahrenheit * 9/5 + 32;
end
```

To get temperature data for the USA, call `worldBankTemps`. If the connection to the World Bank web service times out, the service returns an error message.

```
S = worldBankTemps('USA')
```

```
Error using webread (line 112)
The connection to
URL 'http://climatedataapi.worldbank.org/climateweb/rest/v1/country/cru/tas/year/USA'
timed out after 5.0 seconds. Set options.Timeout to a higher value.
```

If you create `options` and set its `Timeout` property to 60 seconds, then you can call `worldBankTemps` again with `options` as an input argument. `worldBankTemps` passes `options` to `webread` as an input argument. This time `webread` keeps the connection open for a maximum of 60 seconds.

```
options = weboptions('Timeout',60);
S = worldBankTemps('USA',options)
```

```
S =
```

```
          Years: [1x112 double]
DegreesInFahrenheit: [1x112 double]
```

If your code does not allow you to pass request options to `webread`, that limits your ability to respond to error messages returned by web services.

Error Messages Concerning Web Service Options

When you use a web service function in MATLAB the function might return an error message that advises you to set a property of `options`, such as `options.Timeout`. This table shows some typical error messages that refer to `options` properties and actions you can take in response.

Error Message Contains Phrase	Action To Be Taken
Set <code>options.Timeout</code> to a higher value.	<pre>options = weboptions('Timeout',60) data = webread(url,options)</pre>
Set <code>options.ContentType</code> to 'json'.	<pre>options = weboptions('ContentType','json') data = webread(url,options)</pre>
...the provided authentication parameters, <code>options.Username</code> and <code>options.Password</code> , are incorrect.	<pre>options = weboptions('Username','your username','Password','your password') data = webread(url,options)</pre>

Send Email

To send an email from MATLAB, use the `sendmail` function. You can also attach files to an email, which lets you mail files directly from MATLAB. To use `sendmail`, set up your email address and your SMTP server information with the `setpref` function.

The `setpref` function defines two mail-related preferences:

- Email address: This preference sets your email address that will appear on the message.

```
setpref('Internet','E_mail','youraddress@yourserver.com');
```
- SMTP server: This preference sets your outgoing SMTP server address, which can be almost any email server that supports the Post Office Protocol (POP) or the Internet Message Access Protocol (IMAP).

```
setpref('Internet','SMTP_Server','mail.server.network');
```

Find your outgoing SMTP server address in your email account settings in your email client application. You can also contact your system administrator for the information.

Once you have properly configured MATLAB, you can use the `sendmail` function. The `sendmail` function requires at least two arguments: the recipient's email address and the email subject.

```
sendmail('recipient@someserver.com','Hello From MATLAB!');
```

You can supply multiple email addresses using a cell array of character vectors.

```
sendmail({'recipient@someserver.com','recipient2@someserver.com'}, ...  
        'Hello From MATLAB!');
```

You can specify a message body.

```
sendmail('recipient@someserver.com','Hello From MATLAB!', ...  
        'Thanks for using sendmail.');
```

You can attach files to an email.

```
sendmail('recipient@someserver.com','Hello from MATLAB!', ...  
        'Thanks for using sendmail.','C:\yourFileSystem\message.txt');
```

You cannot attach a file without including a message. However, the message can be empty.

You can attach multiple files to an email.

```
sendmail('recipient@someserver.com','Hello from MATLAB!', ...  
        'Thanks for using sendmail.',{'C:\yourFileSystem\message.txt', ...  
        'C:\yourFileSystem\message2.txt'});
```

See Also

`sendmail` | `setpref`

Perform FTP File Operations

This example shows how to use an FTP object to connect to an FTP server and perform remote file operations. To perform any file operation on an FTP server, follow these steps:

- 1 Connect to the server using the `ftp` function.
- 2 Perform operations using the appropriate MATLAB® FTP functions, such as the `cd`, `dir`, and `mget` functions. Specify the FTP object for all operations.
- 3 When you finish work on the server, close the connection using the `close` function.

The National Centers for Environmental Information (NCEI) maintain an anonymous FTP service providing public access to geophysical data. Access the FTP server to list its contents, download a file, and list contents of a subfolder.

First, open the connection.

```
ftpobj = ftp('ftp.ngdc.noaa.gov')
```

```
ftpobj =
```

```
FTP Object
  host: ftp.ngdc.noaa.gov
  user: anonymous
  dir: /
  mode: binary
```

List the contents of the top-level folder on the FTP server.

```
dir(ftpobj)
```

```
DMSP                               Solid_Earth                       google12c4c939d7b90761.html  mgg
INDEX.txt                          coastwatch                        hazards                        pub
README.txt                         dmsp4alan                        index.html                     tmp
STP                                 ftp.html                          international                  wdc
Snow_Ice                           geomag                             ionosonde
```

Download the file named `INDEX.txt` using the `mget` function. `mget` copies the file to the current MATLAB folder on your local machine. To view the contents of your copy of the file, use the `type` function.

```
mget(ftpobj, 'INDEX.txt');
type INDEX.txt
```

```
National Centers for Environmental Information (NCEI),
formerly the National Geophysical Data Center (NGDC)
```

```
INDEX of anonymous ftp area
ftp.ngdc.noaa.gov
```

```
DIRECTORY/FILE DESCRIPTION OF CONTENTS
```

```
-----
pub/          Public access area
DMSP/        Defense Meteorological Satellite Data Archive
```

```
geomag/      Geomagnetism and geomagnetics models
hazards/     Natural Hazards data, volcanoes, tsunamis, earthquakes
international/ International program information on IAGA/Oersted/wdc
ionosonde/   Ionosonde data
mgg/        Limited Marine Geology and Geophysics (most data in http area)
OD/         Office of the Director
Snow_Ice/   Snow and Ice Data Center
Solid_Earth/ Historic Solid Earth Geophysics
STP/        Solar-Terrestrial Physics
tmp/        Pickup area for temporary outgoing data
wdc/        World Data Service for Geophysics, formerly World Data Centers
```

Please see file README.txt in this directory for more information and how to contact NCEI. Direct E-mail inquiries to ncei.info@noaa.gov

Also see our web site: <http://www.ngdc.noaa.gov/>

NCEI is part of the:
U.S. Department of Commerce, National Oceanic and Atmospheric Administration (NOAA),
National Environmental Satellite, Data and Information Service (NESDIS)

Change to the subfolder named `pub` on the FTP server.

```
cd(ftpobj, 'pub')
```

```
ans =  
'/pub'
```

List the contents. `pub` is now the current folder on the FTP server. However, note that the current MATLAB folder on your local machine has not changed. When you specify an FTP object using functions such as `cd` and `dir`, the operations take place on the FTP server, not your local machine.

```
dir(ftpobj)
```

```
WebCD      coast      glac_lib  krm          outgoing  results   rgon
```

Close the connection to the FTP server.

```
close(ftpobj)
```

FTP service courtesy of the NCEI. See the NCEI Privacy Policy, Disclaimer, and Copyright for NCEI terms of service.

See Also

`ftp` | `cd` | `close` | `dir` | `mget`

Related Examples

- “Download Web Page and Files” on page 11-13
- “Send Email” on page 11-16
- “Web Browsers and MATLAB”

Display Hyperlinks in the Command Window

In this section...
“Create Hyperlinks to Web Pages” on page 11-19
“Transfer Files Using FTP” on page 11-19

Create Hyperlinks to Web Pages

When you create a hyperlink to a Web page, append a full hypertext address on a single line as input to the `disp` or `fprintf` command. For example, the following command:

```
disp('<a href = "https://www.mathworks.com">The MathWorks Web Site</a>')
```

displays the following hyperlink in the Command Window:

The MathWorks Web Site

When you click this hyperlink, a MATLAB Web browser opens and displays the requested page.

Transfer Files Using FTP

To create a link to an FTP site, enter the site address as input to the `disp` command as follows:

```
disp('<a href = "ftp://ftp.mathworks.com">The MathWorks FTP Site</a>')
```

This command displays the following as a link in the Command Window:

The MathWorks FTP Site

When you click the link, a MATLAB browser opens and displays the requested FTP site.

Customize JSON Encoding for MATLAB Classes

This example shows how to customize the `jsonencode` function for a user-defined MATLAB class.

This class `Person.m` has a public property `Name` and a private property `Age`. If you call `jsonencode` to encode the data, the function only converts the public property.

```
classdef Person
    properties
        Name;
    end
    properties (Access = private)
        Age;
    end
    methods
        function obj = Person(name,age)
            obj.Name = name;
            obj.Age = age;
        end
    end
end
```

- 1 Display a JSON-encoded instance of `Person`.

```
obj = Person('Luke',19);
jsonencode(obj)
```

```
ans =
```

```
 '{"Name":"Luke"}'
```

- 2 To display the private property `Age`, customize `jsonencode` and add it to the `methods` block of class `Person`:

```
classdef Person
    properties
        Name;
    end
    properties (Access = private)
        Age;
    end
    methods
        function obj = Person(name,age)
            obj.Name = name;
            obj.Age = age;
        end
    end

    function json = jsonencode(obj, varargin)
        s = struct("Name", obj.Name, "Age", obj.Age);
        json = jsonencode(s, varargin{:});
    end
end
```

The signature of the function must match the `jsonencode` signature, which takes a class object as input and returns a string or a character vector in JSON format.

- 3 Display the customized object.

```
obj = Person('Luke',19);  
jsonencode(obj)  
  
ans =  
  
    '{"Name":"Luke","Age":19}'
```

See Also

jsonencode

Serial Port I/O

- “Serial Port Overview” on page 12-2
- “Create Serial Port Object” on page 12-13
- “Configure Serial Port Communication Settings” on page 12-15
- “Write and Read Serial Port Data” on page 12-17
- “Use Callbacks for Serial Port Communication” on page 12-21
- “Use Serial Port Control Pins” on page 12-22
- “Transition Your Code to serialport Interface” on page 12-26
- “Read Streaming Data from Arduino Using Serial Port Communication” on page 12-32
- “Troubleshooting Serial Port Interface” on page 12-35
- “Resolve Serial Port Connection Errors” on page 12-38
- “Serialport Warning - Unable to Read All Data” on page 12-40
- “Serialport Warning - Unable to Read Any Data” on page 12-41

Serial Port Overview

In this section...

“What Is Serial Communication?” on page 12-2
“Serial Port Interface Standard” on page 12-2
“Supported Platforms” on page 12-3
“Connecting Two Devices with a Serial Cable” on page 12-3
“Serial Port Signals and Pin Assignments” on page 12-3
“Serial Data Format” on page 12-6
“Find Serial Port Information for Your Platform” on page 12-9

What Is Serial Communication?

Serial communication is the most common low-level protocol for communicating between two or more devices. Normally, one device is a computer, while the other device can be a modem, a printer, another computer, or a scientific instrument such as an oscilloscope or a function generator.

As the name suggests, the serial port sends and receives bytes of information in a serial fashion—one bit at a time. These bytes are transmitted using either a binary format or a text (ASCII) format.

For many serial port applications, you can communicate with your instrument without detailed knowledge of how the serial port works. Communication is established through a serial port object, which you create in the MATLAB workspace.

If your application is straightforward, or if you are already familiar with the topics mentioned above, you might want to begin with “Create Serial Port Object” on page 12-13.

Serial Port Interface Standard

Over the years, several serial port interface standards for connecting computers to peripheral devices have been developed. These standards include RS-232, RS-422, and RS-485 — all of which are supported by the `serialport` object. The most widely used standard is RS-232.

The current version of this standard is designated TIA/EIA-232C, which is published by the Telecommunications Industry Association. However, the term “RS-232” is still in popular use, and is used here to refer to a serial communication port that follows the TIA/EIA-232 standard. RS-232 defines these serial port characteristics:

- Maximum bit transfer rate and cable length
- Names, electrical characteristics, and functions of signals
- Mechanical connections and pin assignments

Primary communication uses three pins: the Transmit Data pin, the Receive Data pin, and the Ground pin. Other pins are available for data flow control, but are not required.

Note This guide assumes that you are using the RS-232 standard. Refer to your device documentation to see which interface standard you can use.

Supported Platforms

The MATLAB serial port interface is supported on:

- Linux 64-bit
- macOS 64-bit
- Microsoft Windows 64-bit

Connecting Two Devices with a Serial Cable

The RS-232 and RS-485 standard defines the two devices connected with a serial cable as the data terminal equipment (DTE) and data circuit-terminating equipment (DCE). This terminology reflects the RS-232 origin as a standard for communication between a computer terminal and a modem.

In this guide, your computer is considered a DTE, while peripheral devices such as modems and printers are considered DCEs. Note that many scientific instruments function as DTEs.

Because RS-232 mainly involves connecting a DTE to a DCE, the pin assignment definitions specify straight-through cabling, where pin 1 is connected to pin 1, pin 2 is connected to pin 2, and so on. A DTE-to-DCE serial connection using the transmit data (TD) pin and the receive data (RD) pin is shown below. Refer to “Serial Port Signals and Pin Assignments” on page 12-3 for more information about serial port pins.

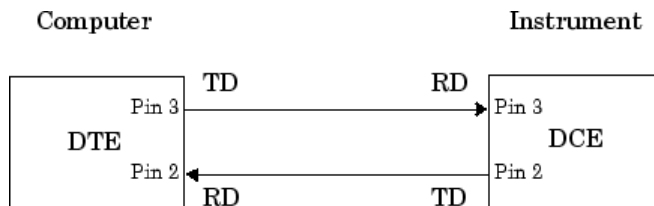

If you connect two DTEs or two DCEs using a straight serial cable, then the TD pin on each device is connected to the other, and the RD pin on each device is connected to the other. Therefore, to connect two like devices, you must use a *null modem* cable. As shown below, null modem cables cross the transmit and receive lines in the cable.

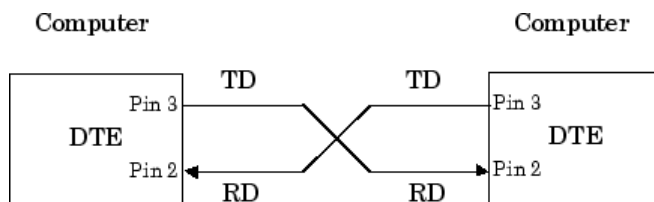

Note You can connect multiple RS-422 or RS-485 devices to a serial port. If you have an RS-232/RS-485 adaptor, then you can use the `serialport` object with these devices.

Serial Port Signals and Pin Assignments

Serial ports consist of two signal types: *data signals* and *control signals*. To support these signal types, as well as the signal ground, the RS-232 standard defines a 25-pin connection. However, most

PCs and UNIX platforms use a 9-pin connection. In fact, only three pins are required for serial port communications: one for receiving data, one for transmitting data, and one for the signal ground.

The following figure shows a pin assignment scheme for a nine-pin male connector on a DTE.

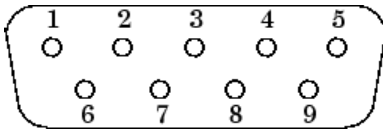

This table describes the pins and signals associated with the nine-pin connector. Refer to the RS-232 or the RS-485 standard for a description of the signals and pin assignments for a 25-pin connector.

Serial Port Pin and Signal Assignments

Pin	Label	Signal Name	Signal Type
1	CD	Carrier Detect	Control
2	RD	Received Data	Data
3	TD	Transmitted Data	Data
4	DTR	Data Terminal Ready	Control
5	GND	Signal Ground	Ground
6	DSR	Data Set Ready	Control
7	RTS	Request to Send	Control
8	CTS	Clear to Send	Control
9	RI	Ring Indicator	Control

The term “data set” is synonymous with “modem” or “device,” while the term “data terminal” is synonymous with “computer.”

Note The serial port pin and signal assignments are with respect to the DTE. For example, data is transmitted from the TD pin of the DTE to the RD pin of the DCE.

Signal States

Signals can be in either an *active state* or an *inactive state*. An active state corresponds to the binary value 1, while an inactive state corresponds to the binary value 0. An active signal state is often described as *logic 1*, *on*, *true*, or a *mark*. An inactive signal state is often described as *logic 0*, *off*, *false*, or a *space*.

For data signals, the “on” state occurs when the received signal voltage is more negative than -3 volts, while the “off” state occurs for voltages more positive than 3 volts. For control signals, the “on” state occurs when the received signal voltage is more positive than 3 volts, while the “off” state occurs for voltages more negative than -3 volts. The voltage between -3 volts and +3 volts is considered a transition region, and the signal state is undefined.

To bring the signal to the “on” state, the controlling device *unasserts* (or *lowers*) the value for data pins and *asserts* (or *raises*) the value for control pins. Conversely, to bring the signal to the “off” state, the controlling device asserts the value for data pins and unasserts the value for control pins.

The following figure depicts the “on” and “off” states for a data signal and for a control signal.

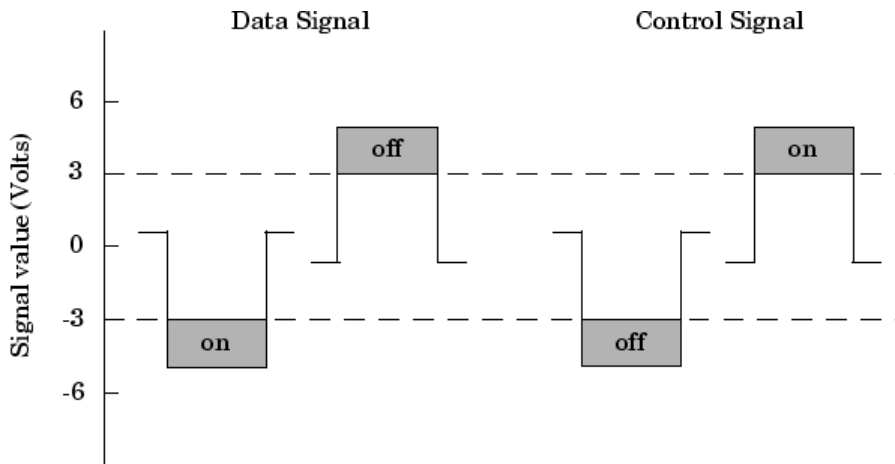

Data Pins

Most serial port devices support *full-duplex* communication, meaning that they can send and receive data at the same time. Therefore, separate pins are used for transmitting and receiving data. For these devices, the TD, RD, and GND pins are used. However, some types of serial port devices support only one-way or *half-duplex* communications. For these devices, only the TD and GND pins are used. This guide assumes that a full-duplex serial port is connected to your device.

The TD pin carries data transmitted by a DTE to a DCE. The RD pin carries data that is received by a DTE from a DCE.

Control Pins

The control pins of a nine-pin serial port are used to determine the presence of connected devices and control the flow of data. The control pins include:

- “RTS and CTS Pins” on page 12-5
- “DTR and DSR Pins” on page 12-6
- “CD and RI Pins” on page 12-6

RTS and CTS Pins

The RTS and CTS pins are used to signal whether the devices are ready to send or receive data. This type of data flow control — called hardware handshaking — is used to prevent data loss during transmission. When enabled for both the DTE and DCE, hardware handshaking using RTS and CTS follows these steps:

- 1 The DTE asserts the RTS pin to instruct the DCE that it is ready to receive data.
- 2 The DCE asserts the CTS pin, indicating that it is clear to send data over the TD pin. If data can no longer be sent, the CTS pin is unasserted.
- 3 The data is transmitted to the DTE over the TD pin. If data can no longer be accepted, the RTS pin is unasserted by the DTE and the data transmission is stopped.

To enable hardware handshaking, refer to “Controlling the Flow of Data: Handshaking” on page 12-24.

DTR and DSR Pins

Many devices use the DSR and DTR pins to signal if they are connected and powered. Signaling the presence of connected devices using DTR and DSR follows these steps:

- 1 The DTE asserts the DTR pin to request that the DCE connect to the communication line.
- 2 The DCE asserts the DSR pin to indicate that it is connected.
- 3 DCE unasserts the DSR pin when it is disconnected from the communication line.

The DTR and DSR pins were originally designed to provide an alternative method of hardware handshaking. However, the RTS and CTS pins are usually used in this way, and not the DSR and DTR pins. Refer to your device documentation to determine its specific pin behavior.

CD and RI Pins

The CD and RI pins are typically used to indicate the presence of certain signals during modem-modem connections.

CD is used by a modem to signal that it has made a connection with another modem, or has detected a carrier tone. CD is asserted when the DCE is receiving a signal of a suitable frequency. CD is unasserted if the DCE is not receiving a suitable signal.

RI is used to indicate the presence of an audible ringing signal. RI is asserted when the DCE is receiving a ringing signal. RI is unasserted when the DCE is not receiving a ringing signal (for example, it is between rings).

Serial Data Format

The serial data format includes one start bit, between five and eight data bits, and one stop bit. A parity bit and an additional stop bit might be included in the format as well. This diagram illustrates the serial data format.



The format for serial port data is often expressed using the following notation:

number of data bits - parity type - number of stop bits

For example, 8-N-1 is interpreted as eight data bits, no parity bit, and one stop bit, while 7-E-2 is interpreted as seven data bits, even parity, and two stop bits.

The data bits are often referred to as a *character* because these bits usually represent an ASCII character. The remaining bits are called *framing bits* because they frame the data bits.

Bytes Versus Values

The collection of bits that compose the serial data format is called a *byte*. At first, this term might seem inaccurate because a byte is 8 bits and the serial data format can range between 7 bits and 12 bits. However, when serial data is stored on your computer, the framing bits are stripped away, and

only the data bits are retained. Moreover, eight data bits are always used regardless of the number of data bits specified for transmission, with the unused bits assigned a value of 0.

When reading or writing data, you might need to specify a *value*, which can consist of one or more bytes. For example, if you read one value from a device using the `int32` format, then that value consists of four bytes. For more information about reading and writing values, refer to “Write and Read Serial Port Data” on page 12-17.

Synchronous and Asynchronous Communication

The RS-232 and the RS-485 standards support two types of communication protocols: synchronous and asynchronous.

Using the synchronous protocol, all transmitted bits are synchronized to a common clock signal. The two devices initially synchronize themselves to each other, and then continually send characters to stay synchronized. Even when actual data is not really being sent, a constant flow of bits allows each device to know where the other is at any given time. That is, each bit that is sent is either actual data or an idle character. Synchronous communications allows faster data transfer rates than asynchronous methods, because additional bits to mark the beginning and end of each data byte are not required.

Using the asynchronous protocol, each device uses its own internal clock, resulting in bytes that are transferred at arbitrary times. So, instead of using time as a way to synchronize the bits, the data format is used.

In particular, the data transmission is synchronized using the start bit of the word, while one or more stop bits indicate the end of the word. The requirement to send these additional bits causes asynchronous communications to be slightly slower than synchronous. However, it has the advantage that the processor does not have to deal with the additional idle characters. Most serial ports operate asynchronously.

Note In this guide, the terms “synchronous” and “asynchronous” refer to whether read or write operations block access to the MATLAB Command Window.

How Are the Bits Transmitted?

By definition, serial data is transmitted one bit at a time. The order in which the bits are transmitted follows these steps:

- 1 The start bit is transmitted with a value of 0.
- 2 The data bits are transmitted. The first data bit corresponds to the least significant bit (LSB), while the last data bit corresponds to the most significant bit (MSB).
- 3 The parity bit (if defined) is transmitted.
- 4 One or two stop bits are transmitted, each with a value of 1.

The number of bits transferred per second is given by the *baud rate*. The transferred bits include the start bit, the data bits, the parity bit (if defined), and the stop bits.

Start and Stop Bits

As described in “Synchronous and Asynchronous Communication” on page 12-7, most serial ports operate asynchronously. This means that the transmitted byte must be identified by start and stop bits. The start bit indicates when the data byte is about to begin and the stop bit indicates when the

data byte has been transferred. The process of identifying bytes with the serial data format follows these steps:

- 1 When a serial port pin is idle (not transmitting data), then it is in an “on” state.
- 2 When data is about to be transmitted, the serial port pin switches to an “off” state due to the start bit.
- 3 The serial port pin switches back to an “on” state due to the stop bit(s). This indicates the end of the byte.

Data Bits

The data bits transferred through a serial port can represent device commands, sensor readings, error messages, and so on. The data can be transferred as either binary data or as text (ASCII) data.

Most serial ports use between five and eight data bits. Binary data is typically transmitted as eight bits. Text-based data is transmitted as either seven bits or eight bits. If the data is based on the ASCII character set, then a minimum of seven bits is required because there are 2^7 or 128 distinct characters. If an eighth bit is used, it must have a value of 0. If the data is based on the extended ASCII character set, then eight bits must be used because there are 2^8 or 256 distinct characters.

Parity Bit

The parity bit provides simple error (parity) checking for the transmitted data. This table describes the types of parity checking.

Parity Types

Parity Type	Description
Even	The data bits plus the parity bit produce an even number of 1s.
Mark	The parity bit is always 1.
Odd	The data bits plus the parity bit produce an odd number of 1s.
Space	The parity bit is always 0.

Mark and space parity checking are seldom used because they offer minimal error detection. You can choose not to use parity checking at all.

The parity checking process follows these steps:

- 1 The transmitting device sets the parity bit to 0 or to 1 depending on the data bit values and the type of parity checking selected.
- 2 The receiving device checks if the parity bit is consistent with the transmitted data. If it is, then the data bits are accepted. If it is not, then an error is returned.

Note Parity checking can detect only one-bit errors. Multiple-bit errors can appear as valid data.

For example, suppose the data bits 01110001 are transmitted to your computer. If even parity is selected, then the parity bit is set to 0 by the transmitting device to produce an even number of 1s. If odd parity is selected, then the parity bit is set to 1 by the transmitting device to produce an odd number of 1s.

Find Serial Port Information for Your Platform

You can find serial port information using the resources provided by Windows and UNIX platforms.

Note Your operating system provides default values for all serial port settings. However, these settings are overridden by your MATLAB code, and have no effect on your serial port application.

Use the `serialportlist` Function to Find Available Ports

The `serialportlist` function returns a list of all serial ports on a system, including virtual serial ports provided by USB-to-serial devices and Bluetooth Serial Port Profile devices. The function provides a list of the serial ports that you have access to on your computer and can use for serial port communication. For example:

```
serialportlist
ans =
    1×3 string array
    "COM1"    "COM3"    "COM4"
```

Note The `serialportlist` function shows both available and in-use ports on Windows and macOS systems, but on Linux, it shows only available ports and not in-use ports.

Windows Platform

You can access serial port information through the **Device Manager**.

- 1 Open **Device Manager**.
- 2 Expand the **Ports (COM & LPT)** list.

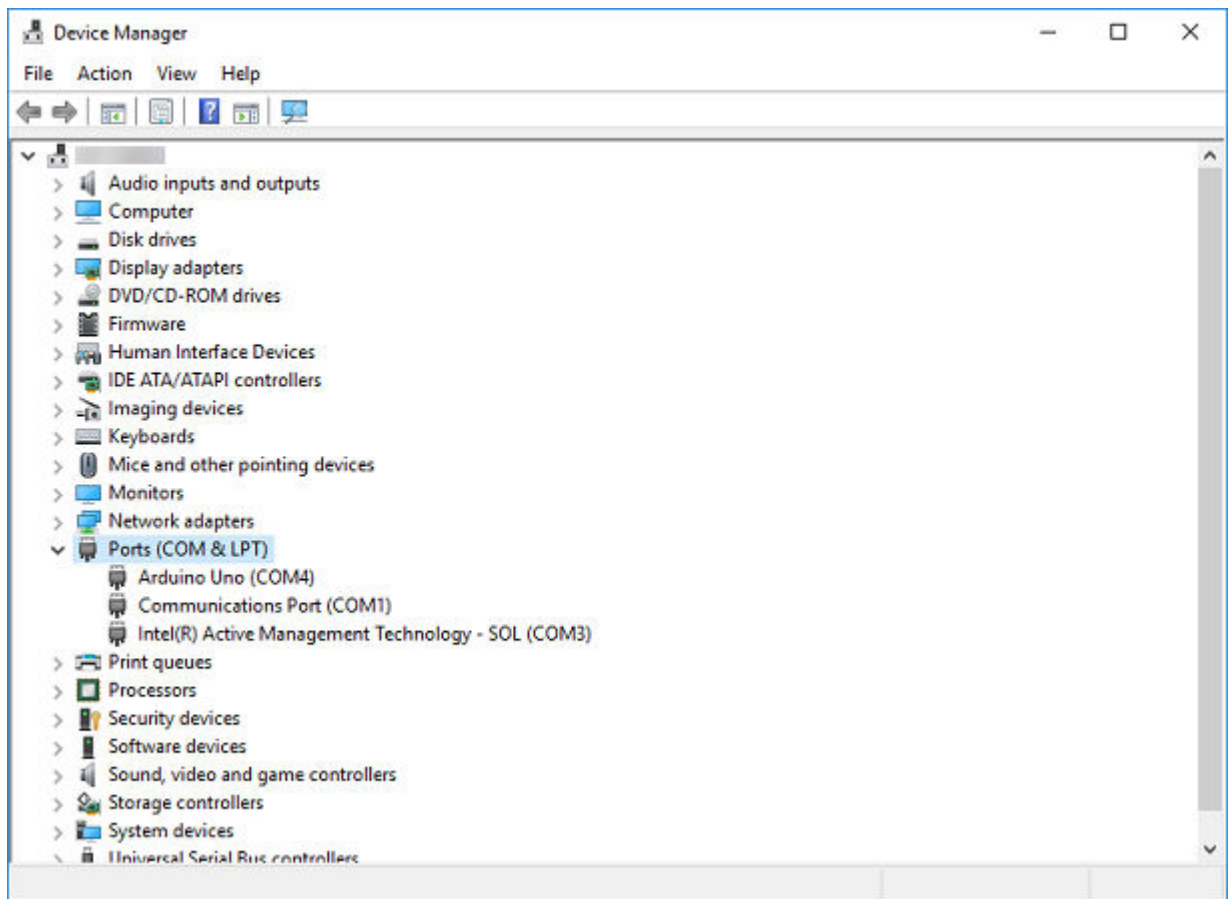

- 3 Double-click the **Communications Port (COM1)** item.
- 4 Select the **Port Settings** tab.

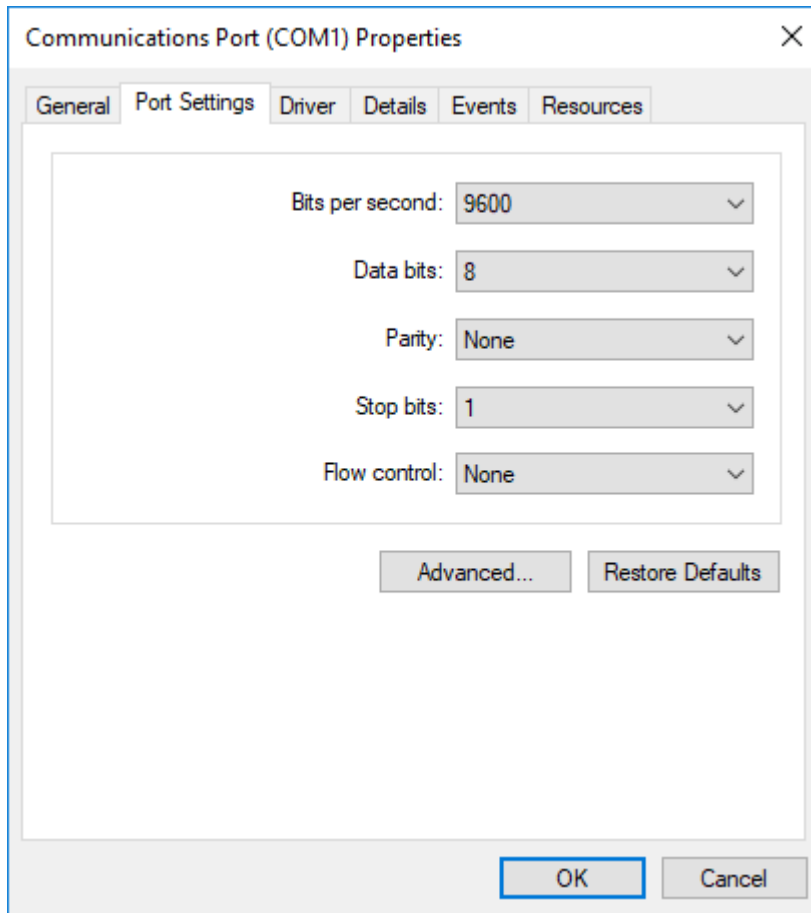

UNIX Platform

To find serial port information for UNIX platforms, you need to know the serial port names. These names can vary between different operating systems.

On Linux, serial port devices are typically named `ttyS0`, `ttyS1`, and so on. You can use the `setserial` command to display or configure serial port information. For example, to display which serial ports are available:

```
setserial -bg /dev/ttyS*
```

```
/dev/ttyS0 at 0x03f8 (irq = 4) is a 16550A
/dev/ttyS1 at 0x02f8 (irq = 3) is a 16550A
```

To display detailed information about `ttyS0`:

```
setserial -ag /dev/ttyS0
```

```
/dev/ttyS0, Line 0, UART: 16550A, Port: 0x03f8, IRQ: 4
  Baud_base: 115200, close_delay: 50, divisor: 0
  closing_wait: 3000, closing_wait2: infinte
  Flags: spd_normal skip_test session_lockout
```

Note If the `setserial -ag` command does not work, make sure that you have read and write permission for the port.

For all supported UNIX platforms, including macOS, you can use the `stty` command to display or configure serial port information. For example, to display serial port properties for `ttyS0`, type:

```
stty -a < /dev/ttyS0
```

To configure the baud rate as 4800 bits per second, type:

```
stty speed 4800 < /dev/ttyS0 > /dev/ttyS0
```

Note This example shows how to set `tty` parameters, not the baud rate. To set the baud rate using the MATLAB serial interface, refer to “Configure Serial Port Communication Settings” on page 12-15.

Create Serial Port Object

In this section...

“Create a Serial Port Object” on page 12-13

“Serial Port Object Display” on page 12-13

Create a Serial Port Object

You create a serial port object with the `serialport` function. `serialport` requires the name of the serial port connected to your device and the baud rate as input arguments. You can also configure property values during object creation using name-value pair arguments.

Each serial port object is associated with one serial port. For example, connect to a device that is on serial port COM1 and configured for a baud rate of 4800.

```
s = serialport("COM1",4800);
```

If the specified port does not exist, or if it is in use, you cannot connect the serial port object to the device. The port name depends on the platform that the serial port is on.

You can also use the `serialportlist` function to return a list of all serial ports on a system, including virtual serial ports provided by USB-to-serial devices and Bluetooth® Serial Port Profile devices. The list shows all serial ports that you have access to on your computer and can use for serial port communication.

```
serialportlist
```

```
ans =
```

```
1×3 string array
```

```
"COM1" "COM3" "COM4"
```

This table shows an example of serial constructors on different platforms.

Platform	Serial Constructor
Linux 64-bit	<code>s = serialport("/dev/ttyS0",9600);</code>
macOS 64-bit	<code>s = serialport("/dev/tty.KeySerial1",9600);</code>
Microsoft Windows 64-bit	<code>s = serialport("COM1",9600);</code>

Note The first time you try to access a serial port in MATLAB using the `s = serialport("COM1",9600)` call, make sure that the port is free and is not already open in any other application. If the port is open in another application, MATLAB cannot access it. After you access the serial port in MATLAB, you can open the same port in other applications, and MATLAB continues to use it along with any other application that has it open as well.

Serial Port Object Display

The serial port object provides a convenient display that summarizes important configuration and state information. You can invoke the display summary in three ways:

- Type the serial port object variable name at the command line.
- Exclude the semicolon when creating a serial port object.
- Exclude the semicolon when configuring properties using dot notation.

You can also display summary information using the workspace browser by right-clicking an instrument object and selecting **Display Summary** from the context menu.

The display summary for the serial port object `s` on a Windows machine is given here.

```
s = serialport("COM4",9600)
s =
  Serialport with properties:
      Port: "COM4"
      BaudRate: 9600
      NumBytesAvailable: 0

  Show all properties, all methods
      Port: "COM4"
      BaudRate: 9600
      NumBytesAvailable: 0

      ByteOrder: "little-endian"
      DataBits: 8
      StopBits: 1
      Parity: "none"
      FlowControl: "none"
      Timeout: 10
      Terminator: "LF"

      BytesAvailableFcnMode: "off"
      BytesAvailableFcnCount: 64
      BytesAvailableFcn: []
      NumBytesWritten: 0

      ErrorOccurredFcn: []
      UserData: []
```

Use dot notation to configure and display property values.

```
s.BaudRate = 4800;
s.BaudRate

ans =

    4800
```

For more information about configuring these properties, see `serialport`.

Configure Serial Port Communication Settings

Before you can write or read data, both the serial port object and the instrument must have identical communication settings. Configuring serial port communications involves specifying values for properties that control the baud rate and the “Serial Data Format” on page 12-6. These properties are as follows.

Serial Port Communication Properties

Property Name	Description
BaudRate	Specify the rate at which bits are transmitted.
Parity	Specify the type of parity checking.
DataBits	Specify the number of data bits to transmit.
StopBits	Specify the number of bits used to indicate the end of a byte.
Terminator	Specify the terminator character.

Caution If the serial port object and the instrument communication settings are not identical, you might not be able to successfully read or write data.

Refer to your instrument documentation for an explanation of its supported communication settings.

You can display the communication property values for the serial port objects created in “Create Serial Port Object” on page 12-13.

```
s = serialport("COM4", 9600)
```

```
s =
```

```
Serialport with properties:
```

```
    Port: "COM4"
    BaudRate: 9600
    NumBytesAvailable: 0
```

```
Show all properties, all methods
```

```
    Port: "COM4"
    BaudRate: 9600
    NumBytesAvailable: 0

    ByteOrder: "little-endian"
    DataBits: 8
    StopBits: 1
    Parity: "none"
    FlowControl: "none"
    Timeout: 10
    Terminator: "LF"
```

```
    BytesAvailableFcnMode: "off"
    BytesAvailableFcnCount: 64
    BytesAvailableFcn: []
    NumBytesWritten: 0
```

```
ErrorOccurredFcn: []  
    UserData: []
```

Write and Read Serial Port Data

In this section...

“Rules for Completing Write and Read Operations” on page 12-17

“Writing and Reading Text Data” on page 12-17

“Writing and Reading Binary Data” on page 12-19

Rules for Completing Write and Read Operations

Completing Write Operations

A write operation using `write` or `writeline` completes when one of these conditions is satisfied:

- The specified data is written.
- The time specified by the `Timeout` property passes.

A text command is processed by the instrument only when it receives the required terminator. For serial port objects, each occurrence of `\n` in the ASCII command is replaced with the `Terminator` property value. The default value of `Terminator` is the line feed character. Refer to the documentation for your instrument to determine the terminator required by your instrument.

Completing Read Operations

A read operation with `read` or `readline` completes when one of these conditions is satisfied:

- The specified number of values is read.
- The time specified by the `Timeout` property passes.
- The terminator specified by the `Terminator` property is read.

Writing and Reading Text Data

This example illustrates how to communicate with a serial port instrument by writing and reading text data.

The instrument is a Tektronix® TDS 210 two-channel oscilloscope connected to the serial port COM1. Therefore, many of the commands in the example are specific to this instrument. A sine wave is input into channel 2 of the oscilloscope, and you want to measure the peak-to-peak voltage of the input signal.

These functions and properties are used when reading and writing text.

Function	Purpose
<code>readline</code>	Read text data from the instrument.
<code>writeline</code>	Write text data to the instrument.
“Terminator”	Character used to terminate commands sent to the instrument.

Note This example is Windows specific.

- 1 Create a serial port object** — Create the serial port object `s` associated with the serial port COM1.

```
s = serialport("COM1",9600);
```

- 2 Write and read data** — Write the `*IDN?` command to the instrument using `writeline`, and then read back the result of the command using `readline`.

```
writeline(s,"*IDN?")  
s.NumBytesAvailable
```

```
ans =
```

```
56
```

```
idn = readline(s)
```

```
idn =
```

```
"TEKTRONIX,TDS 210,0,CF:91.1CT FV:v1.16 TDS2CM:CMV:v1.04"
```

You need to determine the measurement source. Possible measurement sources include channel 1 and channel 2 of the oscilloscope.

```
writeline(s,"MEASUREMENT:IMMED:SOURCE?")  
source = readline(s)
```

```
source =
```

```
"CH1"
```

The scope is configured to return a measurement from channel 1. Because the input signal is connected to channel 2, you must configure the instrument to return a measurement from this channel.

```
writeline(s,"MEASUREMENT:IMMED:SOURCE CH2")  
writeline(s,"MEASUREMENT:IMMED:SOURCE?")  
source = readline(s)
```

```
source =
```

```
"CH2"
```

You can now configure the scope to return the peak-to-peak voltage, and then request the value of this measurement.

```
writeline(s,"MEASUREMENT:MEAS1:TYPE PK2PK")  
writeline(s,"MEASUREMENT:MEAS1:VALUE?")
```

Read back the result using the `readline` function.

```
ptop = readline(s)
```

```
ptop =
```

```
"2.0199999809E0"
```

- 3 Disconnect and clean up** — Clear the serial port object `s` from the MATLAB workspace when you are done working with it.

```
clear s
```

Writing and Reading Binary Data

This example explores binary read and write operations with a serial port object. The instrument used is a Tektronix® TDS 210 oscilloscope.

Functions and Properties

These functions are used when reading and writing binary data.

Function	Purpose
read	Read binary data from the instrument.
write	Write binary data to the instrument.

Configure and Connect to the Serial Object

You need to create a serial object. In this example, create a serial port object associated with the COM1 port.

```
s = serialport("COM1",9600);
```

Write Binary Data

You use the `write` function to write binary data to the instrument. A binary write operation completes when one of these conditions is satisfied:

- All the data is written.
- A timeout occurs as specified by the `Timeout` property.

Note When you perform a write operation, think of the transmitted data in terms of values rather than bytes. A value consists of one or more bytes. For example, one `uint32` value consists of four bytes.

Writing Int16 Binary Data

Write a waveform as an `int16` array.

```
write(s,"Data:Destination RefB","string");
write(s,"Data:Encdg SRPbinary","string");
write(s,"Data:Width 2","string");
write(s,"Data:Start 1","string");

t = (0:499) .* 8 * pi / 500;
data = round(sin(t) * 90 + 127);
write(s,"CURVE #3500","string");
```

Note that one `int16` value consists of two bytes. Therefore, the following command writes 1000 bytes.

```
write(s,data,"int16")
```

Reading Binary Data

You use the `read` function to read binary data from the instrument. A binary read operation completes when one of these conditions is satisfied:

- A timeout occurs as specified by the Timeout property.
- The specified number of values is read.

Note When you perform a read operation, think of the received data in terms of values rather than bytes. A value consists of one or more bytes. For example, one `uint32` value consists of four bytes.

Reading int16 Binary Data

Read the same waveform on channel 1 as an `int16` array.

```
read(s, "Data:Source CH1", "string");
read(s, "Data:Encdg SRPbinary", "string");
read(s, "Data:Width 2", "string");
read(s, "Data:Start 1", "string");
read(s, "Data:Stop 2500", "string");
read(s, "Curve?", "string")
```

Note that one `int16` value consists of two bytes. Therefore, the following command reads 512 bytes.

```
data = read(s, 256, "int16");
```

Disconnect and Clean Up

If you are finished with the serial port object, clear the object from the workspace.

```
clear s
```

Use Callbacks for Serial Port Communication

In this section...
"Callback Properties" on page 12-21
"Using Callbacks" on page 12-21

Callback Properties

The properties and functions associated with callbacks are as follows.

Property or Function	Purpose
NumBytesAvailable	Number of bytes available to read
BytesAvailableFcn	Bytes available callback function
BytesAvailableFcnCount	Number of bytes of data to trigger callback
BytesAvailableFcnMode	Bytes available callback trigger mode
configureCallback	Set serial port callback function and trigger

Using Callbacks

This example uses a loopback device with the callback function `readSerialData` to return data to the command line when a terminator is read.

Note This example is Windows specific.

- 1 Create the callback function** — Define a callback function `readSerialData` that performs a terminated string read and returns the data.

```
function readSerialData(src,~)
    data = readline(src);
    disp(data);
end
```

- 2 Create an instrument object** — Create the serial port object `s` associated with serial port COM1.

```
s = serialport("COM1",9600);
```

- 3 Configure properties** — Configure `s` to execute the callback function `readSerialData` when the terminator is read.

```
configureCallback(s,"terminator",@readSerialData)
```

- 4 Disconnect and clean up** — Clear the objects from the MATLAB workspace when you are done.

```
clear s
```

Use Serial Port Control Pins

In this section...

“Control Pins” on page 12-22

“Signaling the Presence of Connected Devices” on page 12-22

“Controlling the Flow of Data: Handshaking” on page 12-24

Control Pins

As described in “Serial Port Signals and Pin Assignments” on page 12-3, nine-pin serial ports include six control pins. The functions and properties associated with the serial port control pins are as follows.

Function	Purpose
<code>getpinstatus</code>	Get serial pin status.
<code>setRTS</code>	Specify the state of the RTS pin.
<code>setDTR</code>	Specify the state of the DTR pin.
<code>FlowControl</code>	Specify the data flow control method to use.

Signaling the Presence of Connected Devices

DTEs and DCEs often use the CD, DSR, RI, and DTR pins to indicate whether a connection is established between serial port devices. Once the connection is established, you can begin to write or read data.

You can monitor the state of the CD, DSR, and RI pins with the `getpinstatus` function. You can specify the state of the DTR pin with the `setDTR` function.

The following example illustrates how these pins are used when two modems are connected to each other.

Connect Two Modems

This example (shown on a Windows machine) connects two modems to each other through the same computer, and illustrates how you can monitor the communication status for the computer-modem connections, and for the modem-modem connection. The first modem is connected to COM1, while the second modem is connected to COM2.

- 1 Connect to the instruments** — After the modems are powered on, the serial port object `s1` is created for the first modem, and the serial port object `s2` is created for the second modem. Both modems are configured for a baud rate of 9600 bits per second.

```
s1 = serialport("COM1", 9600);
s2 = serialport("COM2", 9600);
```

You can verify that the modems (data sets) are ready to communicate with the computer by examining the value of the Data Set Ready pin using the `getpinstatus` function.

```
getpinstatus(s)
```



```
ans =
    struct with fields:
        ClearToSend: 1
        DataSetReady: 1
        CarrierDetect: 0
        RingIndicator: 0
```

The value of the `DataSetReady` field is 1, or `true`, because both modems were powered on before they were connected to the objects.

- 2 Configure properties** — Both modems are configured for a carriage return (CR) terminator using the `configureTerminator` function.

```
configureTerminator(s1, "CR")
configureTerminator(s2, "CR")
```

- 3 Write and read data** — Write the `atd` command to the first modem using the `writeline` function. This command puts the modem “off the hook,” and is equivalent to manually lifting a phone receiver.

```
writeline(s1, 'atd')
```

Write the `ata` command to the second modem using the `writeline` function. This command puts the modem in “answer mode,” which forces it to connect to the first modem.

```
writeline(s2, 'ata')
```

After the two modems negotiate their connection, you can verify the connection status by examining the value of the Carrier Detect pin using the `getpinstatus` function.

```
getpinstatus(s)
```

```
ans =
    struct with fields:
        ClearToSend: 1
        DataSetReady: 1
        CarrierDetect: 1
        RingIndicator: 0
```

You can also verify the modem-modem connection by reading the descriptive message returned by the second modem.

```
s2.NumBytesAvailable
```

```
ans =
    25
out = read(s2, 25, "uint32")
out =
ata
CONNECT 2400/NONE
```

Now break the connection between the two modems by using the `setDTR` function. You can verify that the modems are disconnected by examining the Carrier Detect pin value using the `getpinstatus` function.

```

setDTR(s1,false)
getpinstatus(s1)

ans =

    struct with fields:
        ClearToSend: 1
        DataSetReady: 1
        CarrierDetect: 0
        RingIndicator: 0

```

4 Disconnect and clean up — Clear the objects from the MATLAB workspace when you are done.

```
clear s1 s2
```

Controlling the Flow of Data: Handshaking

Data flow control or *handshaking* is a method used for communicating between a DCE and a DTE to prevent data loss during transmission. For example, suppose your computer can receive only a limited amount of data before it must be processed. As this limit is reached, a handshaking signal is transmitted to the DCE to stop sending data. When the computer can accept more data, another handshaking signal is transmitted to the DCE to resume sending data.

If supported by your device, you can control data flow using one of these methods:

- “Hardware Handshaking” on page 12-24
- “Software Handshaking” on page 12-25

Note Although you might be able to configure your device for both hardware handshaking and software handshaking at the same time, MATLAB does not support this behavior.

You can specify the data flow control method with the `FlowControl` property. If `FlowControl` is `hardware`, then hardware handshaking is used to control data flow. If `FlowControl` is `software`, then software handshaking is used to control data flow. If `FlowControl` is `none`, then no handshaking is used.

Hardware Handshaking

Hardware handshaking uses specific serial port pins to control data flow. In most cases, these are the RTS and CTS pins. Hardware handshaking using these pins is described in “RTS and CTS Pins” on page 12-5.

If `FlowControl` is `hardware`, then the RTS and CTS pins are automatically managed by the DTE and DCE. You can return the CTS pin value with the `getpinstatus` function. You can configure the RTS pin value with the `setRTS` function.

Note Some devices also use the DTR and DSR pins for handshaking. However, these pins are typically used to indicate that the system is ready for communication, and are not used to control data transmission. In MATLAB, hardware handshaking always uses the RTS and CTS pins.

If your device does not use hardware handshaking in the standard way, then you might need to manually configure the RTS pin using the `setRTS` function. In this case, configure `FlowControl` to

none. If `FlowControl` is hardware, then the `RTS` value that you specify might not be honored. Refer to the device documentation to determine its specific pin behavior.

Software Handshaking

Software handshaking uses specific ASCII characters to control data flow. The following table describes these characters, known as Xon and Xoff (or XON and XOFF).

Software Handshaking Characters

Character	Integer Value	Description
Xon	17	Resume data transmission.
Xoff	19	Pause data transmission.

When you use software handshaking, the control characters are sent over the transmission line the same way as regular data. Therefore, you need only the TD, RD, and GND pins.

The main disadvantage of software handshaking is that you cannot write the Xon or Xoff characters while numerical data is being written to the instrument. This is because numerical data might contain a 17 or 19, which makes it impossible to distinguish between the control characters and the data. However, you can write Xon or Xoff while data is being asynchronously read from the instrument because you are using both the TD and RD pins.

Using Software Handshaking

Suppose you want to use software flow control in conjunction with your serial port application. To do this, you must configure the instrument and the serial port object for software flow control. For a serial port object `s` connected to a Tektronix TDS 210 oscilloscope, this configuration is accomplished with the following commands.

```
writeline(s,"RS232:S0FTF ON")
s.FlowControl = "software";
```

To pause data transfer, you write the numerical value 19 (Xoff) to the instrument.

```
write(s,19,"uint32");
```

To resume data transfer, you write the numerical value 17 (Xon) to the instrument.

```
write(s,17,"uint32");
```

Transition Your Code to serialport Interface

The `serial` function, its object functions, and its properties will be removed. Use `serialport` instead.

serial Interface	serialport Interface	Example
<code>seriallist</code>	<code>serialportlist</code>	"Discover Serial Port Devices" on page 12-27
<code>serial</code> and <code>fopen</code>	<code>serialport</code>	"Connect to Serial Port Device" on page 12-27
<code>fwrite</code>	<code>write</code>	"Read and Write" on page 12-27
<code>fread</code>	<code>read</code>	
<code>fprintf</code>	<code>writeline</code>	"Send a Command" on page 12-28
<code>fscanf</code>	<code>readline</code>	"Read a Terminated String" on page 12-28
<code>fgetl</code>		
<code>fgets</code>		
<code>flushinput</code> and <code>flushoutput</code>	<code>flush</code>	"Flush Data from Memory" on page 12-29
Terminator	<code>configureTerminator</code>	"Set Terminator" on page 12-30
<code>BytesAvailableFcnCount</code> , <code>BytesAvailableFcnMode</code> , <code>BytesAvailableFcn</code> , and <code>BytesAvailable</code>	<code>configureCallback</code> and <code>NumBytesAvailable</code>	"Set Up a Callback Function" on page 12-30
<code>PinStatus</code>	<code>getpinstatus</code>	"Read Serial Pin Status" on page 12-30
<code>DataTerminalReady</code> and <code>RequestToSend</code>	<code>setDTR</code> and <code>setRTS</code>	"Set Serial DTR and RTS Pin States" on page 12-31
<code>ErrorFcn</code>	<code>ErrorOccurredFcn</code>	

Removed Functionality

The `ValuesReceived` and `ValuesSent` properties will be removed. You can calculate the number of values sent using the `NumBytesAvailable` property and the data type of the data available. For example, if the `NumBytesAvailable` is 20 bytes of `uint32` data, the number of values sent is five since each `uint32` value is four bytes.

The `readasync` and `stopasync` functions and the `ReadAsyncMode` and `TransferStatus` properties will be removed. The updated interface reads data asynchronously.

The `BytesToOutput`, `InputBufferSize`, and `OutputBufferSize` properties will be removed. Buffer sizes are automatically managed and sized as needed.

The `BreakInterruptFcn`, `OutputEmptyFcn`, and `PinStatusFcn` properties will be removed. You can set callback functions using `configureCallback` in the updated interface, but not for these properties.

The RecordDetail, RecordMode, RecordName, and RecordStatus properties will be removed.

The TimerFcn and TimerPeriod properties will be removed. Use `timer` instead.

The Name, Type, ObjectVisibility, Status, and Tag properties will be removed.

Discover Serial Port Devices

`seriallist` will be removed. Use `serialportlist` instead.

Connect to Serial Port Device

This example shows how to connect to a serial port device and disconnect from it using the recommended functionality.

Functionality	Use This Instead
<pre>s = serial("COM1"); s.BaudRate = 115200; fopen(s)</pre>	<pre>s = serialport("COM1",115200);</pre>
<pre>fclose(s) delete(s) clear s</pre>	<pre>clear s</pre>

The `fopen` function is not available in the updated interface. The object creation function `serialport` both creates the object and connects the object to the device.

The `fclose` function is not available in the updated interface. The `clear` function disconnects the object from the device when it removes the object from the workspace.

For more information, see `serialport`.

Read and Write

These examples use a loopback device to show how to perform a binary write and read, write a nonterminated command string, and read a fixed-length response string using the recommended functionality.

Functionality	Use This Instead
<pre>% s is a serial object fwrite(s,1:5,"uint32") data = fread(s,5,"uint32") data = 1 2 3 4 5</pre>	<pre>% s is a serialport object write(s,1:5,"uint32") data = read(s,5,"uint32") data = 1 2 3 4 5</pre>

Functionality	Use This Instead
<pre>% s is a serial object command = "start"; fwrite(s,command,"char")</pre>	<pre>% s is a serialport object command = "start"; write(s,command,"char")</pre>
<pre>% s is a serial object length = 5; resp = fread(s,length,"char")</pre> <pre>resp =</pre> <pre> 115</pre> <pre> 116</pre> <pre> 97</pre> <pre> 114</pre> <pre> 116</pre> <pre>resp = char(resp)'</pre> <pre>resp =</pre> <pre> 'start'</pre>	<pre>% s is a serialport object length = 5; resp = read(s,length,"string")</pre> <pre>resp =</pre> <pre> "start"</pre>

For more information, see `write` or `read`.

Send a Command

This example shows how to write a terminated SCPI command using the recommended functionality.

Functionality	Use This Instead
<pre>% s is a serial object s.Terminator = "CR/LF" channel = 1; level = 3.44; fprintf(s,"TRIGGER%d:LEVEL2 %1.2f",[channel],level)</pre>	<pre>% s is a serialport object configureTerminator(s,"CR/LF") channel = 1; level = 3.44; cmd = sprintf("TRIGGER%d:LEVEL2 %1.2f",[channel],level) writeline(s,cmd)</pre> <p>writeline automatically appends the write terminator.</p>

For more information, see `configureTerminator` or `writeline`.

Read a Terminated String

This example shows how to perform a terminated string read using the recommended functionality.

Functionality	Use This Instead
<pre>% s is a serial object fprintf(s, "MEASUREMENT:IMMED:TYPE PK2PK") a = fscanf(s, "%e", 6) a = 2.0200</pre> <p>For the format specifier "%e", fscanf returns the terminator and the user must remove it from the string.</p>	<pre>% s is a serialport object writeline(s, "MEASUREMENT:IMMED:TYPE PK2PK") a = readline(s) a = "2.0200" sscanf(a, "%e") a = 2.0200</pre>
<pre>% s is a serial object fprintf(s, "*IDN?") a = fgetl(s) a = 'TEKTRONIX,TDS 210,0,CF:91.1CT FV:v1.16'</pre> <p>fgetl reads until the specified terminator is reached and then discards the terminator.</p>	<pre>% s is a serialport object writeline(s, "*IDN?") a = readline(s) a = "TEKTRONIX,TDS 210,0,CF:91.1CT FV:v1.16 TDS2CM:CMV:v1.04"</pre> <p>readline reads until the specified terminator is reached and then discards the terminator. There is no option to include the terminator.</p>
<pre>% s is a serial object fprintf(s, "*IDN?") a = fgets(s) a = 'TEKTRONIX,TDS 210,0,CF:91.1CT FV:v1.16 '</pre> <p>fgets reads until the specified terminator is reached and then returns the terminator.</p>	<pre>TDS2CM:CMV:v1.04</pre>

For more information, see [readline](#).

Flush Data from Memory

This example shows how to flush data from the buffer using the recommended functionality.

Functionality	Use This Instead
<pre>% s is a serial object flushinput(s)</pre>	<pre>% s is a serialport object flush(s, "input")</pre>
<pre>% s is a serial object flushoutput(s)</pre>	<pre>% s is a serialport object flush(s, "output")</pre>
<pre>% s is a serial object flushinput(s) flushoutput(s)</pre>	<pre>% s is a serialport object flush(s)</pre>

For more information, see `flush`.

Set Terminator

This example shows how to set the terminator using the recommended functionality.

Functionality	Use This Instead
<code>% s is a serial object</code> <code>s.Terminator = "CR/LF";</code>	<code>% s is a serialport object</code> <code>configureTerminator(s,"CR/LF")</code>
<code>% s is a serial object</code> <code>s.Terminator = {"CR/LF" [10]};</code>	<code>% s is a serialport object</code> <code>configureTerminator(s,"CR/LF",10)</code>

For more information, see `configureTerminator`.

Set Up a Callback Function

This example uses a loopback device to show how to set up a callback function using the recommended functionality.

Functionality	Use This Instead
<pre>s = serial("COM5","BaudRate",115200) s.BytesAvailableFcnCount = 5 s.BytesAvailableFcnMode = "byte" s.BytesAvailableFcn = @instrcallback fopen(s) function instrcallback(src,evt) data = fread(src,src.BytesAvailable) disp(evt) disp(evt.Data) end data = 1 2 3 4 5 Type: 'BytesAvailable' Data: [1x1 struct] AbsTime: [2019 5 2 16 35 9.6710]</pre>	<pre>s = serialport("COM5",115200) configureCallback(s,"byte",5,@instrcallback); function instrcallback(src,evt) data = read(src,src.NumBytesAvailable,"uint8") disp(evt) end data = 1 2 3 4 5 DataAvailableInfo with properties: BytesAvailableFcnCount: 5 AbsTime: 02-May-2019 15:54:09</pre>

For more information, see `configureCallback`.

Read Serial Pin Status

This example shows how to read serial pin status using the recommended functionality.

Functionality	Use This Instead
<pre>% s is a serial object s.PinStatus ans = struct with fields: CarrierDetect: 'on' ClearToSend: 'on' DataSetReady: 'on' RingIndicator: 'on'</pre>	<pre>% s is a serialport object status = getpinstatus(s) status = struct with fields: ClearToSend: 1 DataSetReady: 1 CarrierDetect: 1 RingIndicator: 1</pre>

For more information, see `getpinstatus`.

Set Serial DTR and RTS Pin States

This example shows how to set serial DTR and RTS pin states using the recommended functionality.

Functionality	Use This Instead
<pre>% s is a serial object s.DataTerminalReady = "on";</pre>	<pre>% s is a serialport object setDTR(s,true)</pre>
<pre>% s is a serial object s.RequestToSend = "off";</pre>	<pre>% s is a serialport object setRTS(s,false)</pre>

For more information, see `setDTR` or `setRTS`.

See Also

`serialportlist` | `serialport`

More About

- [serial Properties](#)
- [R2019a serial Interface Topics](#)

Read Streaming Data from Arduino Using Serial Port Communication

This example shows how to enable callbacks to read streaming ASCII terminated data from an Arduino® Due using the `serialport` interface.

Load Program on the Arduino

Plug in an Arduino Due to your computer.

Load the following program on the Arduino Due using the Arduino IDE. This program writes out continuous points of a sine wave, followed by the "Carriage Return" and "Linefeed" terminators.

```
/*
  SineWavePoints

  Write sine wave points to the serial port, followed by the Carriage Return and LineFeed terminators.
*/

int i = 0;

// The setup routine runs once when you press reset:
void setup() {
  // Initialize serial communication at 9600 bits per second:
  Serial.begin(9600);
}

// The loop routine runs over and over again forever:
void loop() {
  // Write the sinewave points, followed by the terminator "Carriage Return" and "Linefeed".
  Serial.print(sin(i*50.0/360.0));
  Serial.write(13);
  Serial.write(10);
  i += 1;
}
```

Establish a Connection to the Arduino

Create a `serialport` instance to connect to your Arduino Due.

Find the serial port that the Arduino is connected to. You can identify the port from the Arduino IDE.

```
serialportlist("available")'
```

```
ans = 3x1 string
    "COM1"
    "COM3"
    "COM13"
```

Connect to the Arduino Due by creating a `serialport` object using the port and baud rate specified in the Arduino code.

```
arduinoObj = serialport("COM13",9600)
```

```
arduinoObj =
Serialport with properties
```

```

        Port: "COM13"
        BaudRate: 9600
    NumBytesAvailable: 0
    NumBytesWritten: 0

```

Show all properties

Prepare the serialport Object to Start Streaming Data

Configure the serialport object by clearing old data and configuring its properties.

Set the Terminator property to match the terminator that you specified in the Arduino code.

```
configureTerminator(arduinoObj, "CR/LF");
```

Flush the serialport object to remove any old data.

```
flush(arduinoObj);
```

Prepare the UserData property to store the Arduino data. The Data field of the struct saves the sine wave value and the Count field saves the x-axis value of the sine wave.

```
arduinoObj.UserData = struct("Data", [], "Count", 1)
```

```
arduinoObj =
Serialport with properties
```

```

        Port: "COM13"
        BaudRate: 9600
    NumBytesAvailable: 10626
    NumBytesWritten: 0

```

Show all properties

Create a callback function readSineWaveData that reads the first 1000 ASCII terminated sine wave data points and plots the result.

```

function readSineWaveData(src, ~)

% Read the ASCII data from the serialport object.
data = readline(src);

% Convert the string data to numeric type and save it in the UserData
% property of the serialport object.
src.UserData.Data(end+1) = str2double(data);

% Update the Count value of the serialport object.
src.UserData.Count = src.UserData.Count + 1;

% If 1001 data points have been collected from the Arduino, switch off the
% callbacks and plot the data.
if src.UserData.Count > 1001
    configureCallback(src, "off");
    plot(src.UserData.Data(2:end));
end
end

```

Set the BytesAvailableFcnMode property to "terminator" and the BytesAvailableFcn property to @readSineWaveData. The callback function readSineWaveData is triggered when a new sine wave data (with the terminator) is available to be read from the Arduino.

```
configureCallback(arduinoObj, "terminator", @readSineWaveData);
```

The callback function opens the MATLAB® figure window with a plot of the first 1000 sine wave data points.

Troubleshooting Serial Port Interface

Serial communication is a low-level protocol for communicating between two or more devices. Normally, one device is a computer, and the other device can be another computer, modem, printer, or scientific instrument such as an oscilloscope or a function generator.

The serial port sends and receives bytes of information in a serial fashion — 1 bit at a time. These bytes are transmitted using either a binary format or a text (ASCII) format.

For many serial port applications, you can communicate with your instrument without detailed knowledge of how the serial port works. Communication is established through a serial port object, which you create in the MATLAB workspace.

Issue

If you are having trouble connecting to or communicating with your serial port device, follow these troubleshooting steps.

Possible Solutions

Supported Platforms

The serial port interface is supported on these platforms:

- Linux 64-bit
- macOS 64-bit
- Microsoft Windows 64-bit

The serial port interface is supported on the same platforms as MATLAB. For updates to the list of currently supported platforms, see System Requirements for MATLAB.

Adaptor Requirements

Use RS-232 interface standard with the serial port communication. Over the years, several serial port interface standards for connecting computers to peripheral devices have been developed. These standards include RS-232, RS-422, and RS-485 — all of which are supported by the serial port object. Of these, the most widely used standard is RS-232, which stands for Recommended Standard number 232.

You need to connect the two devices with a serial cable. For more information, see “Connecting Two Devices with a Serial Cable” on page 12-3.

Serial ports consist of two signal types: *data signals* and *control signals*. To support these signal types, as well as the signal ground, the RS-232 standard defines a 25-pin connection. However, most PCs and UNIX platforms use a 9-pin connection. In fact, only three pins are required for serial port communications: one for receiving data, one for transmitting data, and one for the signal ground. For more information, see “Serial Port Signals and Pin Assignments” on page 12-3.

Configuration and Connection

- 1 Make sure that you have the correct instrument driver installed for your device. Refer to your device documentation and the vendor website.

- 2 Make sure that your device is supported in Instrument Control Toolbox™. See “Is My Hardware Supported?” (Instrument Control Toolbox).
- 3 Make sure that Instrument Control Toolbox recognizes your serial ports, by using the `serialportlist` function. For example, if your computer has more than one serial port, your output would look like this:

```
serialportlist  
  
ans =  
  
    1×3 string array  
  
    "COM1"    "COM3"    "COM4"
```

Tip You can also use Windows device manager to see a list of available serial ports.

- 4 Make sure you can create your serial port object. You must provide two arguments to create the object. For example, create a serial object called `s` using port `COM1` and baud rate `9600`.

```
s = serialport("COM1",9600);
```

If you do not get an error, the object was created successfully.

- 5 When you have connected, you can communicate with your device. If you have problems sending or receiving, you may need to configure communication settings such as `BaudRate`, `DataBits`, `Parity`, `StopBits`, or `Terminator`. Make sure you configure these communication parameters to match those of the connected device.

See “Writing and Reading Text Data” on page 12-17 and “Writing and Reading Binary Data” on page 12-19 for communication examples.

Other Troubleshooting Tips for Serial Port

Verify Port

Verify that the serial (COM) port is listed in Windows Control Panel > Device Manager > Ports.

Sending and Receiving

If you have problems sending or receiving, you may need to configure communication settings such as `BaudRate`, `DataBits`, `Parity`, `StopBits`, or `Terminator`. Make sure you configure these communication parameters to match those of the connected device.

VISA

For serial communication, you can also use VISA with a VISA resource name, as defined in a VISA vendor utility, such as Keysight Connection Expert.

Third-party Software

For troubleshooting serial port communication, you can also use a third-party serial communication software, such as PuTTY or Tera Term, to isolate the issue.

Incorrect Data

When doing binary data communication with `read` and `write`, make sure the correct data type - for example `int16`, `uint16`, `double` - is being used with `read` and `write`. You should use the same data type as the instrument uses.

If reading and writing data types other than `uint8` or `int8`, make sure the `ByteOrder` is correct.

See Also

`serialport` | `serialportlist`

Related Examples

- “Resolve Serial Port Connection Errors” on page 12-38
- “Serialport Warning - Unable to Read Any Data” on page 12-41
- “Serialport Warning - Unable to Read All Data” on page 12-40

Resolve Serial Port Connection Errors

Issue

If you are unable to connect to a serial port device using the `serialport` interface, follow these troubleshooting steps.

Possible Solutions

Check Device Status

Check that the specified port is not in use.

- Make sure that a `serialport` object using the same port number does not already exist in the workspace. You can create only one `serialport` object for each port.
- Check that your device is not in use outside of MATLAB. Disconnect your device from any other devices, applications, or programs.
- Use a third-party serial communication software, such as PuTTY, to check that you can access the specified port from other software.
- Make sure that your device is powered on and connected to your computer.

Verify Port Name

Check that the specified port name is correct and that a device is connected to it.

- Use the `serialportlist` function to return a list of all serial ports that you have access to on your computer. Use `serialportlist("available")` to return a list of only serial ports that are available. Make sure that you are creating a `serialport` object using one of the listed ports.
- Check from your computer settings that the device connected to the serial port is available. For more information on how to view this information on your platform, see “Find Serial Port Information for Your Platform” on page 12-9.

Specify Supported Parameters

Check that the specified parameters are supported by your device.

- Make sure that the baud rate specified as an input argument is supported by your device. Refer to your device documentation for this information. The baud rate must match the device configuration.
- If you have specified any other parameters using name-value arguments, make sure that those are supported by your device as well. You can specify the `DataBits`, `Parity`, `StopBits`, `FlowControl`, `ByteOrder`, and `Timeout` properties using name-value arguments.

Additional Troubleshooting for Virtual Serial Port Connection

If you have devices that present themselves as serial ports on your operating system, you can use them as virtual USB serial ports. One example of such a device is a USB serial dongles.

- If you are connecting to a device over a virtual serial port, check that the device drivers are properly installed.

- If you are using Linux, you might need to enable permissions to read from and write to a virtual serial port. Some Linux distributions require the user account to be a member of the dialout group to have permission to read from and write to the serial port.

See Also

serialport

Related Examples

- “Troubleshooting Serial Port Interface” on page 12-35

Serialport Warning - Unable to Read All Data

These remedies apply to the case when you receive some data and you get this warning message:

```
'serialport' unable to read all requested data.
```

When using the serialport interface for:

- Reading binary data using the `read` function

These are possible causes and remedies:

Cause	Solution
The number of values to read was set to a higher value than what was available to be read.	Set the number of values to read using the input argument <code>count</code> on the <code>read</code> function. For information about setting the number of values to read, see <code>read</code> .
Device did not send all the requested data.	Check your device connection. For more information about troubleshooting configuration and connection, see “Troubleshooting Serial Port Interface” on page 12-35.
There was a data format mismatch.	Verify that the device data format matches the specified read format. Data format is set using the input argument <code>precision</code> on the <code>read</code> function. For more information about supported precisions, see <code>read</code> .

More Troubleshooting Help

For more information about troubleshooting the Serial interface, including supported platforms, adaptor requirements, configuration and connection, and other troubleshooting tips, see “Troubleshooting Serial Port Interface” on page 12-35.

Serialport Warning - Unable to Read Any Data

These remedies apply to the case when you receive no data and you get this warning message:

```
'serialport' unable to read any data.
```

When using the serialport interface for:

- Reading ASCII (text) data using the `readline` function
- Reading binary data using the `read` function

These are possible causes and remedies:

Cause	Solution
An invalid command was sent to the device, so there is a problem reading the response to the command.	Check your device manual for proper command formatting.
Your device is connected to an incorrect serial port.	Verify that your device is connected to the specified port. It must match the port you specify when you create the <code>serialport</code> object. For information about specifying the port, see <code>serialport</code> .
An incorrect write terminator was sent to the instrument before attempting to read data, so there is no data to read.	Verify that the <code>Terminator</code> property is set to the value required by your device. For more information about setting the property, see <code>configureTerminator</code> .
Your device is not configured to send data on the serial port.	Verify the device communication settings. For more information about communication settings, see “Create Serial Port Object” on page 12-13 and “Configure Serial Port Communication Settings” on page 12-15.

More Troubleshooting Help

For more information about troubleshooting the Serial interface, including supported platforms, adaptor requirements, configuration and connection, and other troubleshooting tips, see “Troubleshooting Serial Port Interface” on page 12-35.

Large Data

- “Getting Started with MapReduce” on page 13-3
- “Write a Map Function” on page 13-9
- “Write a Reduce Function” on page 13-13
- “Speed Up and Deploy MapReduce Using Other Products” on page 13-17
- “Build Effective Algorithms with MapReduce” on page 13-18
- “Debug MapReduce Algorithms” on page 13-20
- “Analyze Big Data in MATLAB Using MapReduce” on page 13-25
- “Find Maximum Value with MapReduce” on page 13-33
- “Compute Mean Value with MapReduce” on page 13-36
- “Compute Mean by Group Using MapReduce” on page 13-39
- “Create Histograms Using MapReduce” on page 13-44
- “Simple Data Subsetting Using MapReduce” on page 13-51
- “Using MapReduce to Compute Covariance and Related Quantities” on page 13-57
- “Compute Summary Statistics by Group Using MapReduce” on page 13-62
- “Using MapReduce to Fit a Logistic Regression Model” on page 13-69
- “Tall Skinny QR (TSQR) Matrix Factorization Using MapReduce” on page 13-75
- “Compute Maximum Average HSV of Images with MapReduce” on page 13-80
- “Getting Started with Datastore” on page 13-86
- “Select Datastore for File Format or Application” on page 13-90
- “Work with Remote Data” on page 13-93
- “Read and Analyze Large Tabular Text File” on page 13-98
- “Read and Analyze Image Files” on page 13-100
- “Read and Analyze MAT-File with Key-Value Data” on page 13-104
- “Read and Analyze Hadoop Sequence File” on page 13-107
- “Develop Custom Datastore” on page 13-109
- “Testing Guidelines for Custom Datastores” on page 13-118
- “Develop Custom Datastore for DICOM Data” on page 13-126
- “Set Up Datastore for Processing on Different Machines or Clusters” on page 13-132
- “Apache Parquet Data Type Mappings” on page 13-135
- “Tall Arrays for Out-of-Memory Data” on page 13-146
- “Deferred Evaluation of Tall Arrays” on page 13-152
- “Index and View Tall Array Elements” on page 13-157
- “Histograms of Tall Arrays” on page 13-166
- “Visualization of Tall Arrays” on page 13-171
- “Grouped Statistics Calculations with Tall Arrays” on page 13-179

- “Extend Tall Arrays with Other Products” on page 13-185
- “Analyze Big Data in MATLAB Using Tall Arrays” on page 13-187
- “Develop Custom Tall Array Algorithms” on page 13-196

Getting Started with MapReduce

As the number and type of data acquisition devices grows annually, the sheer size and rate of data being collected is rapidly expanding. These big data sets can contain gigabytes or terabytes of data, and can grow on the order of megabytes or gigabytes per day. While the collection of this information presents opportunities for insight, it also presents many challenges. Most algorithms are not designed to process big data sets in a reasonable amount of time or with a reasonable amount of memory. MapReduce allows you to meet many of these challenges to gain important insights from large data sets.

In this section...

“What Is MapReduce?” on page 13-3

“MapReduce Algorithm Phases” on page 13-3

“Example MapReduce Calculation” on page 13-4

What Is MapReduce?

MapReduce is a programming technique for analyzing data sets that do not fit in memory. You may be familiar with Hadoop® MapReduce, which is a popular implementation that works with the Hadoop Distributed File System (HDFS™). MATLAB provides a slightly different implementation of the MapReduce technique with the `mapreduce` function.

`mapreduce` uses a datastore to process data in small blocks that individually fit into memory. Each block goes through a Map phase, which formats the data to be processed. Then the intermediate data blocks go through a Reduce phase, which aggregates the intermediate results to produce a final result. The Map and Reduce phases are encoded by *map* and *reduce* functions, which are primary inputs to `mapreduce`. There are endless combinations of map and reduce functions to process data, so this technique is both flexible and extremely powerful for tackling large data processing tasks.

`mapreduce` lends itself to being extended to run in several environments. For more information about these capabilities, see “Speed Up and Deploy MapReduce Using Other Products” on page 13-17.

The utility of the `mapreduce` function lies in its ability to perform calculations on large collections of data. Thus, `mapreduce` is not well-suited for performing calculations on *normal* sized data sets which can be loaded directly into computer memory and analyzed with traditional techniques. Instead, use `mapreduce` to perform a statistical or analytical calculation on a data set that does not fit in memory.

Each call to the map or reduce function by `mapreduce` is independent of all others. For example, a call to the map function cannot depend on inputs or results from a previous call to the map function. It is best to break up such calculations into multiple calls to `mapreduce`.

MapReduce Algorithm Phases

`mapreduce` moves each block of data in the input datastore through several phases before reaching the final output. The following figure outlines the phases of the algorithm for `mapreduce`.

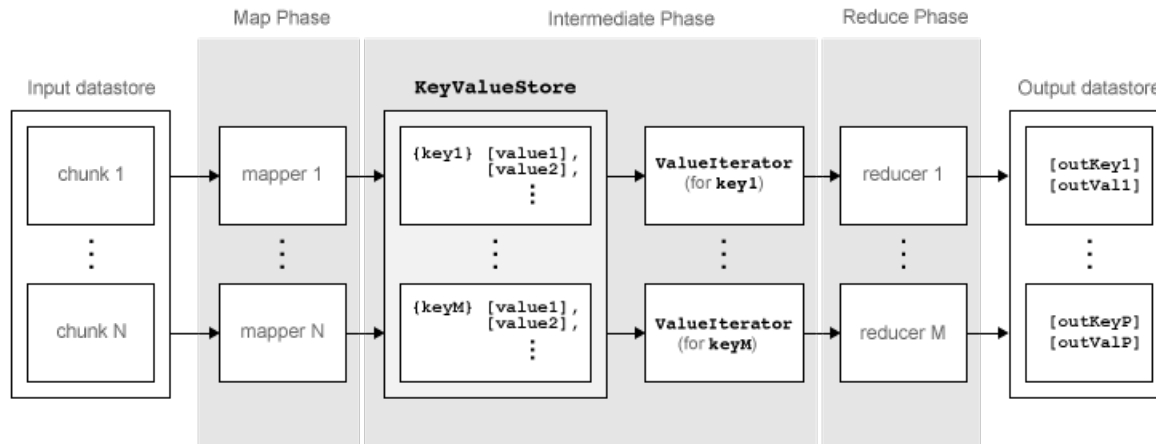

The algorithm has the following steps:

- 1 `mapreduce` reads a block of data from the input datastore using `[data,info] = read(ds)`, and then calls the map function to work on that block.
- 2 The map function receives the block of data, organizes it or performs a precursory calculation, and then uses the `add` and `addmulti` functions to add key-value pairs to an intermediate data storage object called a `KeyValueStore`. The number of calls to the map function by `mapreduce` is equal to the number of blocks in the input datastore.
- 3 After the map function works on all of the blocks of data in the datastore, `mapreduce` groups all of the values in the intermediate `KeyValueStore` object by unique key.
- 4 Next, `mapreduce` calls the reduce function once for each unique key added by the map function. Each unique key can have many associated values. `mapreduce` passes the values to the reduce function as a `ValueIterator` object, which is an object used to iterate over the values. The `ValueIterator` object for each unique key contains all the associated values for that key.
- 5 The reduce function uses the `hasnext` and `getNext` functions to iterate through the values in the `ValueIterator` object one at a time. Then, after aggregating the intermediate results from the map function, the reduce function adds final key-value pairs to the output using the `add` and `addmulti` functions. The order of the keys in the output is the same as the order in which the reduce function adds them to the final `KeyValueStore` object. That is, `mapreduce` does not explicitly sort the output.

Note The reduce function writes the final key-value pairs to a final `KeyValueStore` object. From this object, `mapreduce` pulls the key-value pairs into the output datastore, which is a `KeyValueDataStore` object by default.

Example MapReduce Calculation

This example uses a simple calculation (the mean travel distance in a set of flight data) to illustrate the steps needed to run `mapreduce`.

Prepare Data

The first step to using `mapreduce` is to construct a datastore for the data set. Along with the map and reduce functions, the datastore for a data set is a required input to `mapreduce`, since it allows `mapreduce` to process the data in blocks.

mapreduce works with most types of datastores. For example, create a TabularTextDatastore object for the `airlinesmall.csv` data set.

```
ds = tabularTextDatastore('airlinesmall.csv','TreatAsMissing','NA')
ds =
    TabularTextDatastore with properties:
        Files: {
            '...\matlab\toolbox\matlab\demos\airlinesmall.csv'
        }
        Folders: {
            '...\matlab\toolbox\matlab\demos'
        }
        FileEncoding: 'UTF-8'
        AlternateFileSystemRoots: {}
        PreserveVariableNames: false
        ReadVariableNames: true
        VariableNames: {'Year', 'Month', 'DayofMonth' ... and 26 more}
        DatetimeLocale: en_US

    Text Format Properties:
        NumHeaderLines: 0
        Delimiter: ','
        RowDelimiter: '\r\n'
        TreatAsMissing: 'NA'
        MissingValue: NaN

    Advanced Text Format Properties:
        TextscanFormats: {'%f', '%f', '%f' ... and 26 more}
        TextType: 'char'
        ExponentCharacters: 'eEdD'
        CommentStyle: ''
        Whitespace: ' \b\t'
        MultipleDelimitersAsOne: false

    Properties that control the table returned by preview, read, readall:
        SelectedVariableNames: {'Year', 'Month', 'DayofMonth' ... and 26 more}
        SelectedFormats: {'%f', '%f', '%f' ... and 26 more}
        ReadSize: 20000 rows
        OutputType: 'table'
        RowTimes: []

    Write-specific Properties:
        SupportedOutputFormats: ["txt" "csv" "xlsx" "xls" "parquet" "parq"]
        DefaultOutputFormat: "txt"
```

Several of the previously described options are useful in the context of `mapreduce`. The `mapreduce` function executes `read` on the datastore to retrieve data to pass to the map function. Therefore, you can use the `SelectedVariableNames`, `SelectedFormats`, and `ReadSize` options to directly configure the block size and type of data that `mapreduce` passes to the map function.

For example, to select the `Distance` (total flight distance) variable as the only variable of interest, specify `SelectedVariableNames`.

```
ds.SelectedVariableNames = 'Distance';
```

Now, whenever the `read`, `readall`, or `preview` functions act on `ds`, they will return only information for the `Distance` variable. To confirm this, you can preview the first few rows of data in the datastore. This allows you to examine the format of the data that the `mapreduce` function will pass to the map function.

```
preview(ds)
```

```
ans =
```

```
8x1 table
    Distance
    _____
```

```

308
296
480
296
373
308
447
954

```

To view the *exact* data that `mapreduce` will pass to the map function, use `read`.

For additional information and a complete summary of the available options, see “Datastore”.

Write Map and Reduce Functions

The `mapreduce` function automatically calls the map and reduce functions during execution, so these functions must meet certain requirements to run properly.

- The inputs to the map function are `data`, `info`, and `intermKVStore`:
 - `data` and `info` are the result of a call to the `read` function on the input datastore, which `mapreduce` executes automatically before each call to the map function.
 - `intermKVStore` is the name of the intermediate `KeyValueStore` object to which the map function needs to add key-value pairs. The `add` and `addmulti` functions use this object name to add key-value pairs. If none of the calls to the map function add key-value pairs to `intermKVStore`, then `mapreduce` does not call the reduce function and the resulting datastore is empty.

A simple example of a map function is:

```

function MeanDistMapFun(data, info, intermKVStore)
    distances = data.Distance(~isnan(data.Distance));
    sumLenValue = [sum(distances) length(distances)];
    add(intermKVStore, 'sumAndLength', sumLenValue);
end

```

This map function has only three lines, which perform some straightforward roles. The first line filters out all `NaN` values in the block of distance data. The second line creates a two-element vector with the total distance and count for the block, and the third line adds that vector of values to `intermKVStore` with the key, `'sumAndLength'`. After this map function runs on all of the blocks of data in `ds`, the `intermKVStore` object contains the total distance and count for each block of distance data.

Save this function in your current folder as `MeanDistMapFun.m`.

- The inputs to the reduce function are `intermKey`, `intermValIter`, and `outKVStore`:
 - `intermKey` is for the active key added by the map function. Each call to the reduce function by `mapreduce` specifies a new unique key from the keys in the intermediate `KeyValueStore` object.
 - `intermValIter` is the `ValueIterator` associated with the active key, `intermKey`. This `ValueIterator` object contains all of the values associated with the active key. Scroll through the values using the `hasnext` and `getnext` functions.
 - `outKVStore` is the name for the final `KeyValueStore` object to which the reduce function needs to add key-value pairs. `mapreduce` takes the output key-value pairs from `outKVStore`

and returns them in the output datastore, which is a `KeyValueDatastore` object by default. If none of the calls to the reduce function add key-value pairs to `outKVStore`, then `mapreduce` returns an empty datastore.

A simple example of a reduce function is:

```
function MeanDistReduceFun(intermKey, intermValIter, outKVStore)
    sumLen = [0 0];
    while hasNext(intermValIter)
        sumLen = sumLen + getNext(intermValIter);
    end
    add(outKVStore, 'Mean', sumLen(1)/sumLen(2));
end
```

This reduce function loops through each of the distance and count values in `intermValIter`, keeping a running total of the distance and count after each pass. After this loop, the reduce function calculates the overall mean flight distance with a simple division, and then adds a single key to `outKVStore`.

Save this function in your current folder as `MeanDistReduceFun.m`.

For information about writing more advanced map and reduce functions, see “Write a Map Function” on page 13-9 and “Write a Reduce Function” on page 13-13.

Run mapreduce

After you have a datastore, a map function, and a reduce function, you can call `mapreduce` to perform the calculation. To calculate the average flight distance in the data set, call `mapreduce` using `ds`, `MeanDistMapFun`, and `MeanDistReduceFun`.

```
outds = mapreduce(ds, @MeanDistMapFun, @MeanDistReduceFun);
```

```
*****
*      MAPREDUCE PROGRESS      *
*****
Map   0% Reduce   0%
Map  16% Reduce   0%
Map  32% Reduce   0%
Map  48% Reduce   0%
Map  65% Reduce   0%
Map  81% Reduce   0%
Map  97% Reduce   0%
Map 100% Reduce   0%
Map 100% Reduce 100%
```

By default, the `mapreduce` function displays progress information at the command line and returns a `KeyValueDatastore` object that points to files in the current folder. You can adjust all three of these options using the `Name, Value` pair arguments for `'OutputFolder'`, `'OutputType'`, and `'Display'`. For more information, see the reference page for `mapreduce`.

View Results

Use the `readall` function to read the key-value pairs from the output datastore.

```
readall(outds)
```

```
ans =
```

1×2 table

Key	Value
{'Mean'}	[[702.1630]]

See Also

tabularTextDatastore | mapreduce

Related Examples

- “Build Effective Algorithms with MapReduce” on page 13-18

Write a Map Function

In this section...

“Role of Map Function in MapReduce” on page 13-9

“Requirements for Map Function” on page 13-10

“Sample Map Functions” on page 13-10

Role of Map Function in MapReduce

mapreduce requires both an input map function that receives blocks of data and that outputs intermediate results, and an input reduce function that reads the intermediate results and produces a final result. Thus, it is normal to break up a calculation into two related pieces for the map and reduce functions to fulfill separately. For example, to find the maximum value in a data set, the map function can find the maximum value in each block of input data, and then the reduce function can find the single maximum value among all of the intermediate maxima.

This figure shows the Map phase of the mapreduce algorithm.

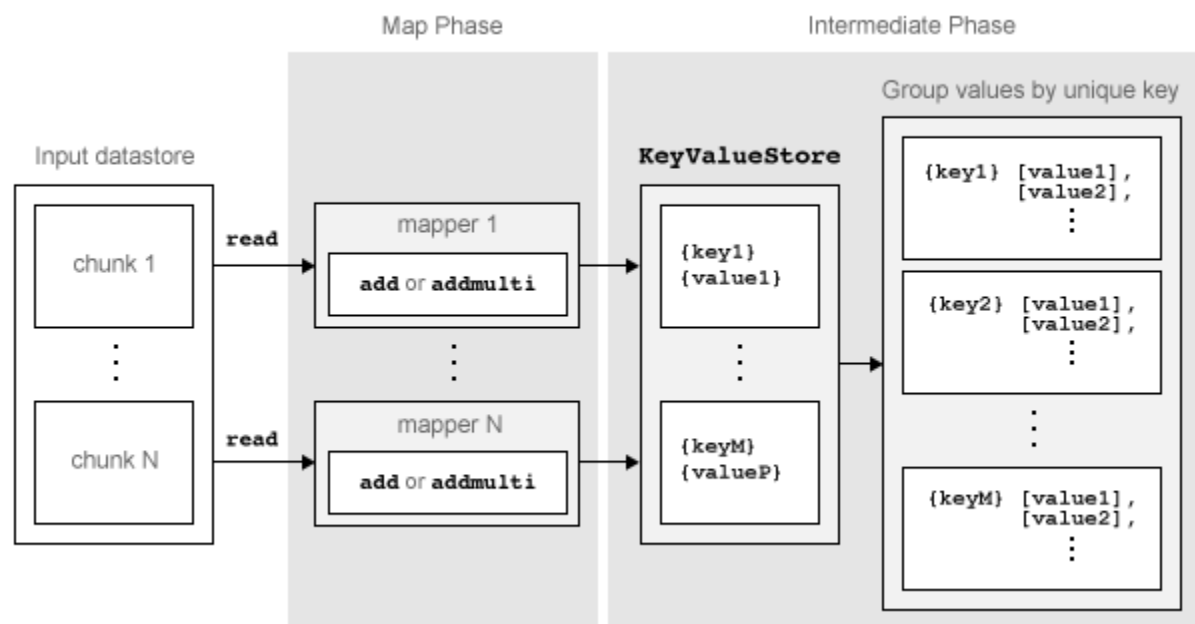

The Map phase of the mapreduce algorithm has the following steps:

- 1 mapreduce reads a single block of data using the read function on the input datastore, then calls the map function to work on the block.
- 2 The map function then works on the individual block of data and adds one or more key-value pairs to the intermediate KeyValueStore object using the add or addmulti functions.
- 3 mapreduce repeats this process for each of the blocks of data in the input datastore, so that the total number of calls to the map function is equal to the number of blocks of data. The ReadSize property of the datastore determines the number of data blocks.

The Map phase of the mapreduce algorithm is complete when the map function processes each of the blocks of data in the input datastore. The result of this phase of the mapreduce algorithm is a

KeyValueStore object that contains all of the key-value pairs added by the map function. After the Map phase, mapreduce prepares for the Reduce phase by grouping all the values in the KeyValueStore object by unique key.

Requirements for Map Function

mapreduce automatically calls the map function for each block of data in the input datastore. The map function must meet certain basic requirements to run properly during these automatic calls. These requirements collectively ensure the proper movement of data through the Map phase of the mapreduce algorithm.

The inputs to the map function are `data`, `info`, and `intermKVStore`:

- `data` and `info` are the result of a call to the `read` function on the input datastore, which mapreduce executes automatically before each call to the map function.
- `intermKVStore` is the name of the intermediate KeyValueStore object to which the map function needs to add key-value pairs. The `add` and `addmulti` functions use this object name to add key-value pairs. If the map function does not add any key-value pairs to the `intermKVStore` object, then mapreduce does not call the reduce function and the resulting datastore is empty.

In addition to these basic requirements for the map function, the key-value pairs added by the map function must also meet these conditions:

- 1 Keys must be numeric scalars, character vectors, or strings. Numeric keys cannot be NaN, complex, logical, or sparse.
- 2 All keys added by the map function must have the same class.
- 3 Values can be any MATLAB object, including all valid MATLAB data types.

Note The above key-value pair requirements may differ when using other products with mapreduce. See the documentation for the appropriate product to get product-specific key-value pair requirements.

Sample Map Functions

Here are a few illustrative map functions used in mapreduce examples.

Identity Map Function

A map function that simply returns what mapreduce passes to it is called an *identity mapper*. An identity mapper is useful to take advantage of the grouping of values by unique key before doing calculations in the reduce function. The `identityMapper` mapper file is one of the mappers used in the example “Tall Skinny QR (TSQR) Matrix Factorization Using MapReduce” on page 13-75.

```
function identityMapper(data, info, intermKVStore)
    % This mapper function simply copies the data and add them to the
    % intermKVStore as intermediate values.
    x = data.Value{:, :};
    add(intermKVStore, 'Identity', x);
end
```

Simple Map Function

One of the simplest examples of a nonidentity mapper is `maxArrivalDelayMapper`, which is the mapper for the example “Find Maximum Value with MapReduce” on page 13-33. For each chunk of input data, this mapper calculates the maximum arrival delay and adds a key-value pair to the intermediate `KeyValueStore`.

```
function maxArrivalDelayMapper (data, info, intermKVStore)
    partMax = max(data.ArrDelay);
    add(intermKVStore, 'PartialMaxArrivalDelay',partMax);
end
```

Advanced Map Function

A more advanced example of a mapper is `statsByGroupMapper`, which is the mapper for the example “Compute Summary Statistics by Group Using MapReduce” on page 13-62. This mapper uses a nested function to calculate several statistical quantities (count, mean, variance, and so on) for each chunk of input data, and then adds several key-value pairs to the intermediate `KeyValueStore` object. Also, this mapper uses four input arguments, whereas `mapreduce` only accepts a map function with three input arguments. To get around this, pass in the extra parameter using an anonymous function during the call to `mapreduce`, as outlined in the example.

```
function statsByGroupMapper(data, ~, intermKVStore, groupVarName)
    % Data is a n-by-3 table. Remove missing values first
    delays = data.ArrDelay;
    groups = data.(groupVarName);
    notNaN = ~isnan(delays);
    groups = groups(notNaN);
    delays = delays(notNaN);
    % Find the unique group levels in this chunk
    [intermKeys,~,idx] = unique(groups, 'stable');
    % Group delays by idx and apply @grpstatsfun function to each group
    intermVals = accumarray(idx,delays,size(intermKeys),@grpstatsfun);
    addmulti(intermKVStore,intermKeys,intermVals);
    function out = grpstatsfun(x)
        n = length(x); % count
        m = sum(x)/n; % mean
        v = sum((x-m).^2)/n; % variance
        s = sum((x-m).^3)/n; % skewness without normalization
        k = sum((x-m).^4)/n; % kurtosis without normalization
        out = {[n, m, v, s, k]};
    end
end
```

More Map Functions

For more information about common programming patterns in map or reduce functions, see “Build Effective Algorithms with MapReduce” on page 13-18.

See Also

`mapreduce` | `tabularTextDatastore` | `add` | `addmulti`

More About

- `KeyValueStore`
- “Write a Reduce Function” on page 13-13

- “Getting Started with MapReduce” on page 13-3

Write a Reduce Function

In this section...

“Role of the Reduce Function in MapReduce” on page 13-13

“Requirements for Reduce Function” on page 13-14

“Sample Reduce Functions” on page 13-14

Role of the Reduce Function in MapReduce

mapreduce requires both an input map function that receives blocks of data and that outputs intermediate results, and an input reduce function that reads the intermediate results and produces a final result. Thus, it is normal to break up a calculation into two related pieces for the map and reduce functions to fulfill separately. For example, to find the maximum value in a data set, the map function can find the maximum value in each block of input data, and then the reduce function can find the single maximum value among all of the intermediate maxima.

This figure shows the Reduce phase of the mapreduce algorithm.

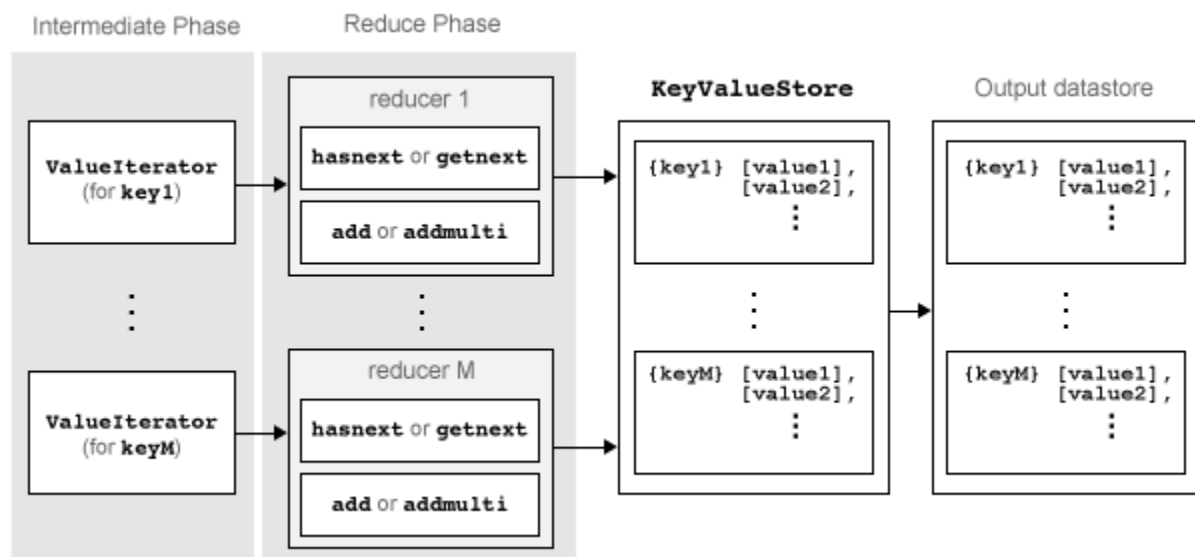

The Reduce phase of the mapreduce algorithm has the following steps:

- 1 The result of the Map phase of the mapreduce algorithm is an intermediate `KeyValueStore` object that contains all of the key-value pairs added by the map function. Before calling the reduce function, mapreduce groups the values in the intermediate `KeyValueStore` object by unique key. Each unique key in the intermediate `KeyValueStore` object results in a single call to the reduce function.
- 2 For each key, mapreduce creates a `ValueIterator` object that contains all of the values associated with that key.
- 3 The reduce function scrolls through the values from the `ValueIterator` object using the `hasnext` and `getnext` functions, which are typically used in a while loop.
- 4 After performing a summary calculation, the reduce function adds one or more key-value pairs to the final `KeyValueStore` object using the `add` and `addmulti` functions.

The Reduce phase of the `mapreduce` algorithm is complete when the reduce function processes all of the unique intermediate keys and their associated values. The result of this phase of the `mapreduce` algorithm (similar to the Map phase) is a `KeyValueStore` object containing all of the final key-value pairs added by the reduce function. After the Reduce phase, `mapreduce` pulls the key-value pairs from the `KeyValueStore` and returns them in a datastore (a `KeyValueDatastore` object by default). The key-value pairs in the output datastore are not in sorted order; they appear in the same order as they were added by the reduce function.

Requirements for Reduce Function

`mapreduce` automatically calls the reduce function for each unique key in the intermediate `KeyValueStore` object, so the reduce function must meet certain basic requirements to run properly during these automatic calls. These requirements collectively ensure the proper movement of data through the Reduce phase of the `mapreduce` algorithm.

The inputs to the reduce function are `intermKey`, `intermValIter`, and `outKVStore`:

- `intermKey` is one of the unique keys added by the map function. Each call to the reduce function by `mapreduce` specifies a new unique key from the keys in the intermediate `KeyValueStore` object.
- `intermValIter` is the `ValueIterator` object associated with the active key, `intermKey`. This `ValueIterator` object contains all of the values associated with the active key. Scroll through the values using the `hasnext` and `getnext` functions.
- `outKVStore` is the name for the final `KeyValueStore` object to which the reduce function needs to add key-value pairs. The `add` and `addmulti` functions use this object name to add key-value pairs to the output. `mapreduce` takes the output key-value pairs from `outKVStore` and returns them in the output datastore, which is a `KeyValueDatastore` object by default. If the reduce function does not add any key-value pairs to `outKVStore`, then `mapreduce` returns an empty datastore.

In addition to these basic requirements for the reduce function, the key-value pairs added by the reduce function must also meet these conditions:

- 1 Keys must be numeric scalars, character vectors, or strings. Numeric keys cannot be `NaN`, logical, complex, or sparse.
- 2 All keys added by the reduce function must have the same class, but that class may differ from the class of the keys added by the map function.
- 3 If the `OutputType` argument of `mapreduce` is `'Binary'` (the default), then a value added by the reduce function can be any MATLAB object, including all valid MATLAB data types.
- 4 If the `OutputType` argument of `mapreduce` is `'TabularText'`, then a value added by the reduce function can be a numeric scalar, character vector, or string. In this case, the value cannot be `NaN`, complex, logical, or sparse.

Note The above key-value pair requirements may differ when using other products with `mapreduce`. See the documentation for the appropriate product to get product-specific key-value pair requirements.

Sample Reduce Functions

Here are a few illustrative reduce functions used in `mapreduce` examples.

Simple Reduce Function

One of the simplest examples of a reducer is `maxArrivalDelayReducer`, which is the reducer for the example “Find Maximum Value with MapReduce” on page 13-33. The map function in this example finds the maximum arrival delay in each chunk of input data. Then the reduce function finishes the task by finding the single maximum value among all of the intermediate maxima. To find the maximum value, the reducer scrolls through the values in the `ValueIterator` object and compares each value to the current maximum. `mapreduce` only calls this reducer function once, since the mapper adds a single unique key to the intermediate `KeyValueStore` object. The reduce function adds a single key-value pair to the output.

```
function maxArrivalDelayReducer(intermKey, intermValIter, outKVStore)
% intermKey is 'PartialMaxArrivalDelay'. intermValIter is an iterator of
% all values that has the key 'PartialMaxArrivalDelay'.
maxVal = -Inf;
while hasNext(intermValIter)
    maxVal = max(getnext(intermValIter), maxVal);
end
% The key-value pair added to outKVStore will become the output of mapreduce
add(outKVStore, 'MaxArrivalDelay', maxVal);
end
```

Advanced Reduce Function

A more advanced example of a reducer is `statsByGroupReducer`, which is the reducer for the example “Compute Summary Statistics by Group Using MapReduce” on page 13-62. The map function in this example groups the data in each input using an extra parameter (airline carrier, month, and so on), and then calculates several statistical quantities for each group of data. The reduce function finishes the task by retrieving the statistical quantities and concatenating them into long vectors, and then using the vectors to calculate the final statistical quantities for count, mean, variance, skewness, and kurtosis. The reducer stores these values as fields in a structure, so that each unique key has a structure of statistical quantities in the output.

```
function statsByGroupReducer(intermKey, intermValIter, outKVStore)
% Reducer function for the StatisticsByGroupMapReduceExample.

% Copyright 2014 The MathWorks, Inc.

n = [];
m = [];
v = [];
s = [];
k = [];

% get all sets of intermediate statistics
while hasNext(intermValIter)
    value = getNext(intermValIter);
    n = [n; value(1)];
    m = [m; value(2)];
    v = [v; value(3)];
    s = [s; value(4)];
    k = [k; value(5)];
end
% Note that this approach assumes the concatenated intermediate values fit
% in memory. Refer to the reducer function, covarianceReducer, of the
% CovarianceMapReduceExample for an alternative pairwise reduction approach

% combine the intermediate results
count = sum(n);
meanVal = sum(n.*m)/count;
d = m - meanVal;
variance = (sum(n.*v) + sum(n.*d.^2))/count;
skewnessVal = (sum(n.*s) + sum(n.*d.*(3*v + d.^2)))/(count*variance^(1.5));
kurtosisVal = (sum(n.*k) + sum(n.*d.*(4*s + 6.*v.*d + d.^3)))/(count*variance^2);
```

```
outValue = struct('Count',count, 'Mean',meanVal, 'Variance',variance,...  
                'Skewness',skewnessVal, 'Kurtosis',kurtosisVal);  
  
% add results to the output datastore  
add(outKVStore,intermKey,outValue);
```

More Reduce Functions

For more information about common programming patterns in map or reduce functions, see “Build Effective Algorithms with MapReduce” on page 13-18.

See Also

mapreduce | tabularTextDatastore | add | addmulti | hasNext | getNext

More About

- [KeyValueStore](#)
- [ValueIterator](#)
- “Write a Map Function” on page 13-9
- “Getting Started with MapReduce” on page 13-3

Speed Up and Deploy MapReduce Using Other Products

In this section...
“Execution Environment” on page 13-17
“Running in Parallel” on page 13-17
“Application Deployment” on page 13-17

Execution Environment

To use `mapreduce` with Parallel Computing Toolbox™, MATLAB Parallel Server™, or MATLAB Compiler™, use the `mapreducer` configuration function to change the execution environment for `mapreduce`. This enables you to start small to verify your map and reduce functions, then quickly scale up to run larger calculations.

Running in Parallel

Parallel Computing Toolbox can immediately speed up your `mapreduce` algorithms by using the full processing power of multicore computers to execute applications with a parallel pool of workers. If you already have Parallel Computing Toolbox installed, then you probably do not need to do anything special to take advantage of these capabilities. For more information about using `mapreduce` with Parallel Computing Toolbox, see “Run `mapreduce` on a Parallel Pool” (Parallel Computing Toolbox).

MATLAB Parallel Server enables you to run the same applications on a remote computer cluster. For more information, including how to configure MATLAB Parallel Server to support Hadoop clusters, see “Tall Arrays and `mapreduce`” (Parallel Computing Toolbox).

Application Deployment

MATLAB Compiler enables you to create standalone `mapreduce` applications or deployable archives, which you can share with colleagues or deploy to production Hadoop systems.

For more information, see “MapReduce Applications on Hadoop Clusters” (MATLAB Compiler).

See Also

`mapreducer` | `gcmr`

Build Effective Algorithms with MapReduce

The mapreduce example files that ship with MATLAB illustrate different programming techniques. You can use these examples as a starting point to quickly prototype similar mapreduce calculations.

Note The associated files for these examples are all in the `toolbox/matlab/demos/` folder.

Example Link	Primary File	Description	Notable Programming Techniques
“Find Maximum Value with MapReduce” on page 13-33	MaxMapReduceExample.m	Find maximum arrival delay	One intermediate key and minimal computation.
“Compute Mean Value with MapReduce” on page 13-36	MeanMapReduceExample.m	Find mean arrival delay	One intermediate key with intermediate state (accumulating intermediate sum and count).
“Create Histograms Using MapReduce” on page 13-44	VisualizationMapReduceExample.m	Visualize data using histograms	Low-volume summaries of data, sufficient to generate a graphic and gain preliminary insights.
“Compute Mean by Group Using MapReduce” on page 13-39	MeanByGroupMapReduceExample.m	Compute mean arrival delay for each day of the week	Perform simple computations on subgroups of input data using several intermediate keys.
“Compute Maximum Average HSV of Images with MapReduce” on page 13-80	HueSaturationValueExample.m	Determine average maximum hue, saturation, and brightness in an image collection	Analyzes an image datastore using three intermediate keys. The outputs are filenames, which can be used to view the images.
“Simple Data Subsetting Using MapReduce” on page 13-51	SubsettingMapReduceExample.m	Create single table from subset of large data set	Extraction of subset of large data set to look for patterns. The procedure is generalized using a parameterized map function to pass in the subsetting criteria.

Example Link	Primary File	Description	Notable Programming Techniques
"Using MapReduce to Compute Covariance and Related Quantities" on page 13-57	CovarianceMapReduceExample.m	Compute covariance and related quantities	Calculate several intermediate values and store them with the same key. Use covariance to obtain a correlation matrix and regression coefficients, and to perform principal components analysis.
"Compute Summary Statistics by Group Using MapReduce" on page 13-62	StatisticsByGroupMapReduceExample.m	Compute summary statistics organized by group	Use an anonymous function to pass an extra grouping parameter to a parameterized map function. This parameterization allows you to quickly recalculate statistics using different grouping variables.
"Using MapReduce to Fit a Logistic Regression Model" on page 13-69	LogitMapReduceExample.m	Fit simple logistic regression model	Chain multiple <code>mapreduce</code> calls to carry out an iterative regression algorithm. An anonymous function passes information from one iteration to the next to supply information directly to the map function.
"Tall Skinny QR (TSQR) Matrix Factorization Using MapReduce" on page 13-75	TSQRMapReduceExample.m	Tall skinny QR decomposition	Chain multiple <code>mapreduce</code> calls to perform multiple iterations of factorizations. Also use the <code>info</code> input argument of the map function to compute intermediate numeric keys.

Debug MapReduce Algorithms

This example shows how to debug your mapreduce algorithms in MATLAB using a simple example file, `MaxMapReduceExample.m`. Debugging enables you to follow the movement of data between the different phases of mapreduce execution and inspect the state of all intermediate variables.

In this section...

“Set Breakpoint” on page 13-20

“Execute mapreduce” on page 13-20

“Step Through Map Function” on page 13-21

“Step Through Reduce Function” on page 13-22

Set Breakpoint

Set one or more breakpoints in your map or reduce function files so you can examine the variable values where you think the problem is. For more information, see “Set Breakpoints”.

Open the file `maxArrivalDelayMapper.m`.

```
edit maxArrivalDelayMapper.m
```

Set a breakpoint on line 9. This breakpoint causes execution of `mapreduce` to pause right before each call to the map function adds a key-value pair to the intermediate `KeyValueStore` object, named `intermKVStore`.

```

1  function maxArrivalDelayMapper (data, info, intermKVStore)
2      % Mapper function for the MaxMapreduceExample.
3
4      % Copyright 1984-2014 The MathWorks, Inc.
5
6      % Data is an n-by-1 table of the ArrDelay. As the data source is tabular,
7      % the return of read is a table object.
8  -  partMax = max(data.ArrDelay);
9  ●  add(intermKVStore, 'PartialMaxArrivalDelay',partMax);

```

Execute mapreduce

Run the mapreduce example file `MaxMapReduceExample.m`. Specify `mapreducer(0)` to ensure that the algorithm does not run in parallel, since parallel execution of `mapreduce` using `Parallel Computing Toolbox` ignores breakpoints.

```
mapreducer(0);
MaxMapReduceExample
```

MATLAB stops execution of the file when it encounters the breakpoint in the map function. During the pause in execution, you can hover over the different variable names in the map function, or type one of the variable names at the command line to inspect the values.

In this case, the display indicates that, as yet, there are no key-value pairs in `intermKVStore`.

```

1 function maxArrivalDelayMapper (data, info, intermKVStore)
2     % Mapper function for the MaxMapreduceExample.
3
4     % Copyright 1984-2014 The MathWorks, Inc.
5
6     % Data is an n-by-1 table of the ArrDelay. As the data source is tabular,
7     % the return of read is a table object.
8     partMax = max(data.ArrDelay);
9     add(intermKVStore, 'PartialMaxArrivalDelay',partMax);

```

```



intermKVStore: 1x1 matlab.mapreduce.KeyValueStore =
KeyValueStore with no key-value pairs.

Keys must be numeric scalars or strings, and values may be any type.

Use add or addmulti to add more key-value pairs.

```

Step Through Map Function

- 1 Continue past the breakpoint. You can use `dbstep` to execute a single line, or `dbcont` to continue execution until MATLAB encounters another breakpoint. Alternatively, you can click  **Step** or  **Continue** in the **Editor** tab. For more information about all the available options, see “Debug MATLAB Code Files”.

In this case, use `dbstep` (or click  **Step**) to execute only line 9, which adds a key-value pair to `intermKVStore`. Inspect the new display for `intermKVStore`.

```

1 function maxArrivalDelayMapper (data, info, intermKVStore)
2     % Mapper function for the MaxMapreduceExample.
3
4     % Copyright 1984-2014 The MathWorks, Inc.
5
6     % Data is an n-by-1 table of the ArrDelay. As the data source is tabular,
7     % the return of read is a table object.
8     partMax = max(data.ArrDelay);
9     add(intermKVStore, 'PartialMaxArrivalDelay',partMax);

```

```

intermKVStore: 1x1 matlab.mapreduce.KeyValueStore =
KeyValueStore containing string keys.



Keys must be strings, and values may be any type.

Last 1 key-value pair added:

      Key          Value
-----
'PartialMaxArrivalDelay' [186]

Use add or addmulti to add more key-value pairs.

```

- 2 Now, use `dbcont` (or click  **Continue**) to continue execution of `mapreduce`. During the *next* call to the map function, MATLAB halts again on line 9. The new display for `intermKVStore` indicates that it does not contain any key-value pairs, because the display is meant to show only the *most recent* key-value pairs that are added in the current call to the map (or reduce) function.
- 3 Step past line 9 again using `dbstep` (or click  **Step**) to add the next key-value pair to `intermKVStore`, and inspect the new display for the variable. MATLAB displays only the key-value pair added during the current call to the map function.

```

1 function maxArrivalDelayMapper (data, info, intermKVStore)
2     % Mapper function for the MaxMapreduceExample.
3
4     % Copyright 1984-2014 The MathWorks, Inc.
5
6     % Data is an n-by-1 table of the ArrDelay. As the data source is tabular,
7     % the return of read is a table object.
8     partMax = max(data.ArrDelay);
9     add(intermKVStore, 'PartialMaxArrivalDelay', partMax);

```

```

intermKVStore: 1x1 matlab.mapreduce.KeyValueStore =
KeyValueStore containing string keys.
Keys must be strings, and values may be any type.
Last 1 key-value pair added:

```

Key	Value
'PartialMaxArrivalDelay'	[339]

```

Use add or addmulti to add more key-value pairs.

```

- 4 Complete the debugging of the map function by removing the breakpoint and closing the file `maxArrivalDelayMapper.m`.

Step Through Reduce Function

- 1 You can use the same process to set breakpoints and step through execution of a reduce function. The reduce function for this example is `maxArrivalDelayReducer.m`. Open this file for editing.
`edit maxArrivalDelayReducer.m`
- 2 Set two breakpoints: one on line 10, and one on line 13. This enables you to inspect the `ValueIterator` and the final key-value pairs added to the output, `outKVStore`.
- 3 Run the main example file.
`MaxMapReduceExample`
- 4 The execution of the example will pause when the breakpoint on line 10 is encountered. The debug display for the `ValueIterator` indicates the active key and whether any values remain to be retrieved.

```



1  function maxArrivalDelayReducer(intermKey, intermValIter, outKVStore)
2      % Reducer function for the MaxMapreduceExample.
3
4      % Copyright 2014 The MathWorks, Inc.
5
6      % intermKey is 'PartialMaxArrivalDelay'. intermValIter is an iterator of
7      % all values that has the key 'PartialMaxArrivalDelay'.
8      maxVal = -inf;
9      while hasNext(intermValIter)
10         maxVal = max(getnext(intermValIter), maxVal);
11     end
12     % The key-value pair add
13     add(outKVStore, 'MaxArriv

```

```

intermValIter: 1x1 matlab.mapreduce.ValueIterator =
ValueIterator with properties:
    Key: 'PartialMaxArrivalDelay'
One or more values are available.
Use hasNext to check if more values are available. Use getNext to get the next value.

```

- 5 Now, remove the breakpoint on line 10 and use **dbcont** (or click  **Continue**) to continue execution of the example until the next breakpoint is reached (on line 13). Since this reduce function continually compares each new value from the `ValueIterator` to the global maximum, `mapreduce` execution ends by adding a single key-value pair to `outKVStore`.
- 6 Use **dbstep** (or click  **Step**) to execute line 13 only. The display for `outKVStore` shows the global maximum value that `mapreduce` will return as the final answer.

```

1  function maxArrivalDelayReducer(intermKey, intermValIter, outKVStore)
2  % Reducer function for the MaxMapreduceExample.
3
4  % Copyright 2014 The MathWorks, Inc.
5
6  % intermKey is 'PartialMaxArrivalDelay'. intermValIter is an iterator of
7  % all values that has the key 'PartialMaxArrivalDelay'.
8  maxVal = -inf;
9  while hasNext(intermValIter)
10     maxVal = max(getnext(intermValIter), maxVal);
11 end
12 % The key-value pair added to outKVStore will become the output of mapreduce
13 add(outKVStore, 'MaxArrivalDelay', maxVal);

```

```

outKVStore: 1x1 matlab.mapreduce.KeyValueStore =
KeyValueStore containing string keys.

Keys must be strings, and values may be any type.

Last 1 key-value pair added:

      Key      Value
-----
'MaxArrivalDelay'  [1014]

Use add or addmulti to add more key-value pairs.

```

7

Now use `dbcont` (or click  **Continue**) to advance execution, enabling the example to finish running. `mapreduce` returns the final results.

```
Map 100% Reduce 100%
```

```
ans =
```

Key	Value
'MaxArrivalDelay'	[1014]

For a complete guide to debugging in MATLAB, see “Debugging and Analysis”.

See Also

`mapreduce`

More About

- `KeyValueStore`
- `ValueIterator`
- “Getting Started with MapReduce” on page 13-3

Analyze Big Data in MATLAB Using MapReduce

This example shows how to use the `mapreduce` function to process a large amount of file-based data. The MapReduce algorithm is a mainstay of many modern "big data" applications. This example operates on a single computer, but the code can scale up to use Hadoop®.

Throughout this example, the data set is a collection of records from the American Statistical Association for USA domestic airline flights between 1987 and 2008. If you have experimented with "big data" before, you may already be familiar with this data set. A small subset of this data set is included with MATLAB® to allow you to run this and other examples.

Introduction to Datastores

Creating a datastore allows you to access a collection of data in a block-based manner. A datastore can process arbitrarily large amounts of data, and the data can even be spread across multiple files. You can create a datastore for many file types, including a collection of tabular text files (demonstrated here), a SQL database (Database Toolbox™ required) or a Hadoop® Distributed File System (HDFS™).

Create a datastore for a collection of tabular text files and preview the contents.

```
ds = tabularTextDatastore('airlinesmall.csv');
dsPreview = preview(ds);
dsPreview(:,10:15)
```

```
ans=8×6 table
  FlightNum   TailNum   ActualElapsedTime   CRSElapsedTime   AirTime   ArrDelay
  _____  _____  _____  _____  _____  _____
      1503      {'NA'}           53              57      {'NA'}           8
      1550      {'NA'}           63              56      {'NA'}           8
      1589      {'NA'}           83              82      {'NA'}          21
      1655      {'NA'}           59              58      {'NA'}          13
      1702      {'NA'}           77              72      {'NA'}           4
      1729      {'NA'}           61              65      {'NA'}          59
      1763      {'NA'}           84              79      {'NA'}           3
      1800      {'NA'}          155             143      {'NA'}          11
```

The datastore automatically parses the input data and makes a best guess as to the type of data in each column. In this case, use the `'TreatAsMissing'` name-value pair argument to replace the missing values correctly. For numeric variables (such as `'AirTime'`), `tabularTextDatastore` replaces every instance of `'NA'` with a NaN value, which is the IEEE arithmetic representation for Not-a-Number.

```
ds = tabularTextDatastore('airlinesmall.csv', 'TreatAsMissing', 'NA');
ds.SelectedFormats{strcmp(ds.SelectedVariableNames, 'TailNum')} = '%s';
ds.SelectedFormats{strcmp(ds.SelectedVariableNames, 'CancellationCode')} = '%s';
dsPreview = preview(ds);
dsPreview(:,{'AirTime', 'TaxiIn', 'TailNum', 'CancellationCode'})
```

```
ans=8×4 table
  AirTime   TaxiIn   TailNum   CancellationCode
  _____  _____  _____  _____
```

```

NaN      NaN      {'NA'}      {'NA'}
NaN      NaN      {'NA'}      {'NA'}
NaN      NaN      {'NA'}      {'NA'}
NaN      NaN      {'NA'}      {'NA'}
NaN      NaN      {'NA'}      {'NA'}
NaN      NaN      {'NA'}      {'NA'}
NaN      NaN      {'NA'}      {'NA'}
NaN      NaN      {'NA'}      {'NA'}

```

Scan for rows of interest

Datastore objects contain an internal pointer to keep track of which block of data the `read` function returns next. Use the `hasdata` and `read` functions to step through the entire data set, and filter the data set to only the rows of interest. In this case, the rows of interest are flights on United Airlines ("UA") departing from Boston ("BOS").

```

subset = [];

while hasdata(ds)
    t = read(ds);
    t = t(strcmp(t.UniqueCarrier, 'UA') & strcmp(t.Origin, 'BOS'), :);
    subset = vertcat(subset, t);
end

subset(1:10, [9, 10, 15:17])

```

```

ans=10x5 table
  UniqueCarrier  FlightNum  ArrDelay  DepDelay  Origin
  _____  _____  _____  _____  _____
  {'UA'}         121         -9         0         {'BOS'}
  {'UA'}         1021        -9         -1         {'BOS'}
  {'UA'}         519         15         8         {'BOS'}
  {'UA'}         354         9          8         {'BOS'}
  {'UA'}         701        -17         0         {'BOS'}
  {'UA'}         673         -9         -1         {'BOS'}
  {'UA'}         91          -3         2         {'BOS'}
  {'UA'}         335         18         4         {'BOS'}
  {'UA'}         1429        1          -2         {'BOS'}
  {'UA'}         53          52         13         {'BOS'}

```

Introduction to mapreduce

MapReduce is an algorithmic technique to "divide and conquer" big data problems. In MATLAB, `mapreduce` requires three input arguments:

- 1 A datastore to read data from
- 2 A "mapper" function that is given a subset of the data to operate on. The output of the map function is a partial calculation. `mapreduce` calls the mapper function one time for each block in the datastore, with each call operating independently.
- 3 A "reducer" function that is given the aggregate outputs from the mapper function. The reducer function finishes the computation begun by the mapper function, and outputs the final answer.

This is an over-simplification to some extent, since the output of a call to the mapper function can be shuffled and combined in interesting ways before being passed to the reducer function. This will be examined later in this example.

Use mapreduce to perform a computation

A simple use of `mapreduce` is to find the longest flight time in the entire airline data set. To do this:

- 1 The "mapper" function computes the maximum of each block from the datastore.
- 2 The "reducer" function then computes the maximum value among all of the maxima computed by the calls to the mapper function.

First, reset the datastore and filter the variables to the one column of interest.

```
reset(ds);
ds.SelectedVariableNames = {'ActualElapsedTime'};
```

Write the mapper function, `maxTimeMapper.m`. It takes three input arguments:

- 1 The input data, which is a table obtained by applying the `read` function to the datastore.
- 2 A collection of configuration and contextual information, `info`. This can be ignored in most cases, as it is here.
- 3 An intermediate data storage object, which records the results of the calculations from the mapper function. Use the `add` function to add Key/Value pairs to this intermediate output. In this example, the name of the key ('MaxElapsedTime') is arbitrary.

Save the following mapper function (`maxTimeMapper.m`) in your current folder.

```
function maxTimeMapper(data, ~, intermKVStore)
    maxElapsedTime = max(data{:, :});
    add(intermKVStore, "MaxElapsedTime", maxElapsedTime)
end
```

Next, write the reducer function. It also takes three input arguments:

- 1 A set of input "keys". Keys will be discussed further below, but they can be ignored in some simple problems, as they are here.
- 2 An intermediate data input object that `mapreduce` passes to the reducer function. This data is in the form of Key/Value pairs, and you use the `hasnext` and `getnext` functions to iterate through the values for each key.
- 3 A final output data storage object. Use the `add` and `addmulti` functions to directly add Key/Value pairs to the output.

Save the following reducer function (`maxTimeReducer.m`) in your current folder.

```
function maxTimeReducer(~, intermValsIter, outKVStore)
    maxElapsedTime = -Inf;
    while(hasnext(intermValsIter))
        maxElapsedTime = max(maxElapsedTime, getnext(intermValsIter));
    end
    add(outKVStore, "MaxElapsedTime", maxElapsedTime);
end
```

Once the mapper and reducer functions are written and saved in your current folder, you can call `mapreduce` using the datastore, mapper function, and reducer function. If you have `Parallel`

Computing Toolbox (PCT), MATLAB will automatically start a pool and parallelize execution. Use the `readall` function to display the results of the MapReduce algorithm.

```
result = mapreduce(ds, @maxTimeMapper, @maxTimeReducer);
```

```
*****
*      MAPREDUCE PROGRESS      *
*****
Map   0% Reduce   0%
Map  16% Reduce   0%
Map  32% Reduce   0%
Map  48% Reduce   0%
Map  65% Reduce   0%
Map  81% Reduce   0%
Map  97% Reduce   0%
Map 100% Reduce   0%
Map 100% Reduce 100%
```

```
readall(result)
```

```
ans=1x2 table
      Key      Value
-----
{'MaxElapsedTime'}  {[1650]}
```

Use of keys in mapreduce

The use of keys is an important and powerful feature of `mapreduce`. Each call to the mapper function adds intermediate results to one or more named "buckets", called keys. The number of calls to the mapper function by `mapreduce` corresponds to the number of blocks in the datastore.

If the mapper function adds values to multiple keys, this leads to multiple calls to the reducer function, with each call working on only one key's intermediate values. The `mapreduce` function automatically manages this data movement between the map and reduce phases of the algorithm.

This flexibility is useful in many contexts. The example below uses keys in a relatively obvious way for illustrative purposes.

Calculating group-wise metrics with mapreduce

The behavior of the mapper function in this application is more complex. For every flight carrier found in the input data, use the `add` function to add a vector of values. This vector is a count of the number of flights for that carrier on each day in the 21+ years of data. The carrier code is the key for this vector of values. This ensures that all of the data for each carrier will be grouped together when `mapreduce` passes it to the reducer function.

Save the following mapper function (`countFlightsMapper.m`) in your current folder.

```
function countFlightsMapper(data, ~, intermKVStore)
    dayNumber = days((datetime(data.Year, data.Month, data.DayOfMonth) - datetime(1987,10,1)))+1;
    daysSinceEpoch = days(datetime(2008,12,31) - datetime(1987,10,1))+1;
    [airlineName, ~, airlineIndex] = unique(data.UniqueCarrier, 'stable');

    for i = 1:numel(airlineName)
        dayTotals = accumarray(dayNumber(airlineIndex==i), 1, [daysSinceEpoch, 1]);
        add(intermKVStore, airlineName{i}, dayTotals);
    end
```



```
end
end
```

The reducer function is less complex. It simply iterates over the intermediate values and adds the vectors together. At completion, it outputs the values in this aggregate vector. Note that the reducer function does not need to sort or examine the `intermediateKeysIn` values; each call to the reducer function by `mapreduce` only passes the values for one airline carrier.

Save the following reducer function (`countFlightsReducer.m`) in your current folder.

```
function countFlightsReducer(intermKeysIn, intermValsIter, outKVStore)
    daysSinceEpoch = days(datetime(2008,12,31) - datetime(1987,10,1))+1;
    dayArray = zeros(daysSinceEpoch, 1);

    while hasNext(intermValsIter)
        dayArray = dayArray + getNext(intermValsIter);
    end
    add(outKVStore, intermKeysIn, dayArray);
end
```

Reset the datastore and select the variables of interest. Once the mapper and reducer functions are written and saved in your current folder, you can call `mapreduce` using the datastore, mapper function, and reducer function.

```
reset(ds);
ds.SelectedVariableNames = {'Year', 'Month', 'DayofMonth', 'UniqueCarrier'};
result = mapreduce(ds, @countFlightsMapper, @countFlightsReducer);
```

```
*****
*      MAPREDUCE PROGRESS      *
*****
Map   0% Reduce   0%
Map  16% Reduce   0%
Map  32% Reduce   0%
Map  48% Reduce   0%
Map  65% Reduce   0%
Map  81% Reduce   0%
Map  97% Reduce   0%
Map 100% Reduce   0%
Map 100% Reduce  10%
Map 100% Reduce  21%
Map 100% Reduce  31%
Map 100% Reduce  41%
Map 100% Reduce  52%
Map 100% Reduce  62%
Map 100% Reduce  72%
Map 100% Reduce  83%
Map 100% Reduce  93%
Map 100% Reduce 100%
```

```
result = readall(result);
```

In case this example was run with only the sample data set, load the results of the `mapreduce` algorithm run on the entire data set.

```
load airlineResults
```

Visualizing the results

Using only the top 7 carriers, smooth the data to remove the effects of weekend travel. This would otherwise clutter the visualization.

```
lines = result.Value;  
lines = horzcat(lines{:});  
[~,sortOrder] = sort(sum(lines), 'descend');  
lines = lines(:,sortOrder(1:7));  
result = result(sortOrder(1:7),:);
```

```
lines(lines==0) = nan;  
lines = smoothdata(lines, 'gaussian');
```

Plot the data.

```
figure('Position',[1 1 800 600]);  
plot(datetime(1987,10,1):caldays(1):datetime(2008,12,31),lines,'LineWidth',2)  
title('Domestic airline flights per day per carrier')  
xlabel('Date')  
ylabel('Flights per day')  
legend(result.Key, 'Location', 'Best')
```

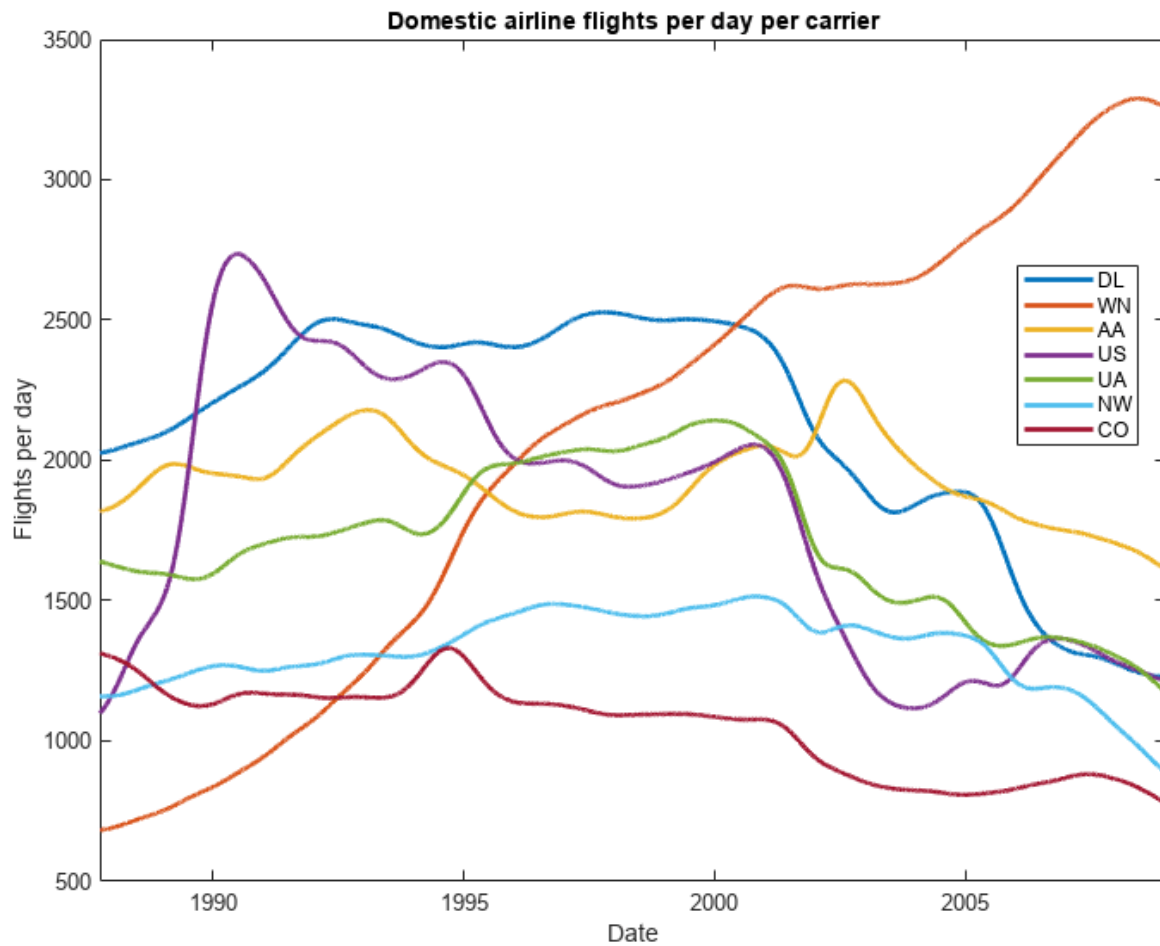

The plot shows the emergence of Southwest Airlines (WN) during this time period.

Learning more

This example only scratches the surface of what is possible with `mapreduce`. See the documentation for `mapreduce` for more information, including information on using it with Hadoop and MATLAB® Parallel Server™.

Local Functions

Listed here are the local functions that `mapreduce` applies to the data.

```
function maxTimeMapper(data, ~, intermKVStore)
    maxElapsedTime = max(data{:, :});
    add(intermKVStore, "MaxElapsedTime", maxElapsedTime)
end
%-----
function maxTimeReducer(~, intermValsIter, outKVStore)
    maxElapsedTime = -Inf;
    while(hasnext(intermValsIter))
        maxElapsedTime = max(maxElapsedTime, getnext(intermValsIter));
    end
end
```

```
    end
    add(outKVStore, "MaxElapsedTime", maxElapsedTime);
end
%-----
function countFlightsMapper(data, ~, intermKVStore)
    dayNumber = days((datetime(data.Year, data.Month, data.DayofMonth) - datetime(1987,10,1))+1);
    daysSinceEpoch = days(datetime(2008,12,31) - datetime(1987,10,1))+1;
    [airlineName, ~, airlineIndex] = unique(data.UniqueCarrier, 'stable');

    for i = 1:numel(airlineName)
        dayTotals = accumarray(dayNumber(airlineIndex==i), 1, [daysSinceEpoch, 1]);
        add(intermKVStore, airlineName{i}, dayTotals);
    end
end
%-----
function countFlightsReducer(intermKeysIn, intermValsIter, outKVStore)
    daysSinceEpoch = days(datetime(2008,12,31) - datetime(1987,10,1))+1;
    dayArray = zeros(daysSinceEpoch, 1);

    while hasNext(intermValsIter)
        dayArray = dayArray + getNext(intermValsIter);
    end
    add(outKVStore, intermKeysIn, dayArray);
end
%-----
```

See Also

mapreduce | tabularTextDatastore

More About

- “Getting Started with MapReduce” on page 13-3
- “Build Effective Algorithms with MapReduce” on page 13-18

Find Maximum Value with MapReduce

This example shows how to find the maximum value of a single variable in a data set using `mapreduce`. It demonstrates the simplest use of `mapreduce` since there is only one key and minimal computation.

Prepare Data

Create a datastore using the `airlinesmall.csv` data set. This 12-megabyte data set contains 29 columns of flight information for several airline carriers, including arrival and departure times. In this example, select `ArrDelay` (flight arrival delay) as the variable of interest.

```
ds = tabularTextDatastore('airlinesmall.csv', 'TreatAsMissing', 'NA');
ds.SelectedVariableNames = 'ArrDelay';
```

The datastore treats 'NA' values as missing, and replaces the missing values with NaN values by default. Additionally, the `SelectedVariableNames` property allows you to work with only the selected variable of interest, which you can verify using `preview`.

```
preview(ds)

ans=8x1 table
  ArrDelay
  -----
         8
         8
        21
        13
         4
        59
         3
        11
```

Run MapReduce

The `mapreduce` function requires a map function and a reduce function as inputs. The mapper receives blocks of data and outputs intermediate results. The reducer reads the intermediate results and produces a final result.

In this example, the mapper finds the maximum arrival delay in each block of data. The mapper then stores these maximum values as the intermediate values associated with the key 'PartialMaxArrivalDelay'.

Display the map function file.

```
function maxArrivalDelayMapper (data, info, intermKVStore)
    partMax = max(data.ArrDelay);
    add(intermKVStore, 'PartialMaxArrivalDelay', partMax);
end
```

The reducer receives a list of the maximum arrival delays for each block and finds the overall maximum arrival delay from the list of values. `mapreduce` only calls this reducer once, since the mapper only adds a single unique key. The reducer uses `add` to add a final key-value pair to the output.

Display the reduce function file.

```
function maxArrivalDelayReducer(intermKey, intermValIter, outKVStore)
% intermKey is 'PartialMaxArrivalDelay'. intermValIter is an iterator of
% all values that has the key 'PartialMaxArrivalDelay'.
maxVal = -Inf;
while hasNext(intermValIter)
    maxVal = max(getnext(intermValIter), maxVal);
end
% The key-value pair added to outKVStore will become the output of mapreduce
add(outKVStore, 'MaxArrivalDelay', maxVal);
end
```

Use mapreduce to apply the map and reduce functions to the datastore, ds.

```
maxDelay = mapreduce(ds, @maxArrivalDelayMapper, @maxArrivalDelayReducer);
```

```
*****
*      MAPREDUCE PROGRESS      *
*****
Map   0% Reduce   0%
Map  16% Reduce   0%
Map  32% Reduce   0%
Map  48% Reduce   0%
Map  65% Reduce   0%
Map  81% Reduce   0%
Map  97% Reduce   0%
Map 100% Reduce   0%
Map 100% Reduce 100%
```

mapreduce returns a datastore, maxDelay, with files in the current folder.

Read the final result from the output datastore, maxDelay.

```
readall(maxDelay)

ans=1x2 table
      Key      Value
-----
{'MaxArrivalDelay'}  {[1014]}
```

Local Functions

Listed here are the map and reduce functions that mapreduce applies to the data.

```
function maxArrivalDelayMapper (data, info, intermKVStore)
    partMax = max(data.ArrDelay);
    add(intermKVStore, 'PartialMaxArrivalDelay', partMax);
end
%-----
function maxArrivalDelayReducer(intermKey, intermValIter, outKVStore)
% intermKey is 'PartialMaxArrivalDelay'. intermValIter is an iterator of
% all values that has the key 'PartialMaxArrivalDelay'.
maxVal = -Inf;
while hasNext(intermValIter)
    maxVal = max(getnext(intermValIter), maxVal);
end
```

```
% The key-value pair added to outKVStore will become the output of mapreduce
add(outKVStore, 'MaxArrivalDelay', maxVal);
end
%-----
```

See Also

mapreduce | tabularTextDatastore

More About

- “Getting Started with MapReduce” on page 13-3
- “Build Effective Algorithms with MapReduce” on page 13-18

Compute Mean Value with MapReduce

This example shows how to compute the mean of a single variable in a data set using `mapreduce`. It demonstrates a simple use of `mapreduce` with one key, minimal computation, and an intermediate state (accumulating intermediate sum and count).

Prepare Data

Create a datastore using the `airlinesmall.csv` data set. This 12-megabyte data set contains 29 columns of flight information for several airline carriers, including arrival and departure times. In this example, select `ArrDelay` (flight arrival delay) as the variable of interest.

```
ds = tabularTextDatastore('airlinesmall.csv', 'TreatAsMissing', 'NA');
ds.SelectedVariableNames = 'ArrDelay';
```

The datastore treats 'NA' values as missing, and replaces the missing values with NaN values by default. Additionally, the `SelectedVariableNames` property allows you to work with only the selected variable of interest, which you can verify using `preview`.

```
preview(ds)

ans=8x1 table
  ArrDelay
  -----
         8
         8
        21
        13
         4
        59
         3
        11
```

Run MapReduce

The `mapreduce` function requires a map function and a reduce function as inputs. The mapper receives blocks of data and outputs intermediate results. The reducer reads the intermediate results and produces a final result.

In this example, the mapper finds the count and sum of the arrival delays in each block of data. The mapper then stores these values as the intermediate values associated with the key "PartialCountSumDelay".

Display the map function file.

```
function meanArrivalDelayMapper (data, info, intermKVStore)
    % Data is an n-by-1 table of the ArrDelay. Remove missing values first:
    data(isnan(data.ArrDelay),:) = [];

    % Record the partial counts and sums and the reducer will accumulate them.
    partCountSum = [length(data.ArrDelay), sum(data.ArrDelay)];
    add(intermKVStore, "PartialCountSumDelay", partCountSum);
end
```

The reducer accepts the count and sum for each block stored by the mapper. It sums up the values to obtain the total count and total sum. The overall mean arrival delay is a simple division of the values. `mapreduce` only calls this reducer once, since the mapper only adds a single unique key. The reducer uses `add` to add a single key-value pair to the output.

Display the reduce function file.

```
function meanArrivalDelayReducer(intermKey, intermValIter, outKVStore)
    count = 0;
    sum = 0;
    while hasNext(intermValIter)
        countSum = getNext(intermValIter);
        count = count + countSum(1);
        sum = sum + countSum(2);
    end
    meanDelay = sum/count;

    % The key-value pair added to outKVStore will become the output of mapreduce
    add(outKVStore, "MeanArrivalDelay", meanDelay);
end
```

Use `mapreduce` to apply the map and reduce functions to the datastore, `ds`.

```
meanDelay = mapreduce(ds, @meanArrivalDelayMapper, @meanArrivalDelayReducer);
```

```
*****
*      MAPREDUCE PROGRESS      *
*****
Map   0% Reduce   0%
Map  16% Reduce   0%
Map  32% Reduce   0%
Map  48% Reduce   0%
Map  65% Reduce   0%
Map  81% Reduce   0%
Map  97% Reduce   0%
Map 100% Reduce   0%
Map 100% Reduce 100%
```

`mapreduce` returns a datastore, `meanDelay`, with files in the current folder.

Read the final result from the output datastore, `meanDelay`.

```
readall(meanDelay)

ans=1x2 table
      Key      Value
-----
{'MeanArrivalDelay'}  {[7.1201]}
```

Local Functions

Listed here are the map and reduce functions that `mapreduce` applies to the data.

```
function meanArrivalDelayMapper (data, info, intermKVStore)
    % Data is an n-by-1 table of the ArrDelay. Remove missing values first:
    data(isnan(data.ArrDelay),:) = [];
```

```
% Record the partial counts and sums and the reducer will accumulate them.
partCountSum = [length(data.ArrDelay), sum(data.ArrDelay)];
add(intermKVStore, "PartialCountSumDelay", partCountSum);
end
%-----
function meanArrivalDelayReducer(intermKey, intermValIter, outKVStore)
    count = 0;
    sum = 0;
    while hasNext(intermValIter)
        countSum = getNext(intermValIter);
        count = count + countSum(1);
        sum = sum + countSum(2);
    end
    meanDelay = sum/count;

    % The key-value pair added to outKVStore will become the output of mapreduce
    add(outKVStore, "MeanArrivalDelay", meanDelay);
end
%-----
```

See Also

mapreduce | tabularTextDatastore

More About

- “Getting Started with MapReduce” on page 13-3
- “Build Effective Algorithms with MapReduce” on page 13-18

Compute Mean by Group Using MapReduce

This example shows how to compute the mean by group in a data set using mapreduce. It demonstrates how to do computations on subgroups of data.

Prepare Data

Create a datastore using the `airlinesmall.csv` data set. This 12-megabyte data set contains 29 columns of flight information for several airline carriers, including arrival and departure times. In this example, select `DayOfWeek` and `ArrDelay` (flight arrival delay) as the variables of interest.

```
ds = tabularTextDatastore('airlinesmall.csv', 'TreatAsMissing', 'NA');
ds.SelectedVariableNames = {'ArrDelay', 'DayOfWeek'};
```

The datastore treats 'NA' values as missing, and replaces the missing values with NaN values by default. Additionally, the `SelectedVariableNames` property allows you to work with only the selected variables of interest, which you can verify using `preview`.

```
preview(ds)
```

```
ans=8x2 table
```

ArrDelay	DayOfWeek
8	3
8	1
21	5
13	5
4	4
59	3
3	4
11	6

Run MapReduce

The `mapreduce` function requires a map function and a reduce function as inputs. The mapper receives blocks of data and outputs intermediate results. The reducer reads the intermediate results and produces a final result.

In this example, the mapper computes the count and sum of delays by the day of week in each block of data, and then stores the results as intermediate key-value pairs. The keys are integers (1 to 7) representing the days of the week and the values are two-element vectors representing the count and sum of the delay of each day.

Display the map function file.

```
function meanArrivalDelayByDayMapper(data, ~, intermKVStore)
% Data is an n-by-2 table: first column is the DayOfWeek and the second
% is the ArrDelay. Remove missing values first.
delays = data.ArrDelay;
day = data.DayOfWeek;
notNaN = ~isnan(delays);
day = day(notNaN);
delays = delays(notNaN);
```

```

% find the unique days in this chunk
[intermKeys,~,idx] = unique(day, 'stable');

% group delays by idx and apply @grpstatsfun function to each group
intermVals = accumarray(idx,delays,size(interKeys),@countsum);
addmulti(interKVStore,interKeys,intermVals);

function out = countsum(x)
    n = length(x); % count
    s = sum(x); % mean
    out = {[n, s]};
end
end

```

After the Map phase, `mapreduce` groups the intermediate key-value pairs by unique key (in this case, day of the week). Thus, each call to the reducer works on the values associated with one day of the week. The reducer receives a list of the intermediate count and sum of delays for the day specified by the input key (`intermKey`) and sums up the values into the total count, `n` and total sum `s`. Then, the reducer calculates the overall mean, and adds one final key-value pair to the output. This key-value pair represents the mean flight arrival delay for one day of the week.

Display the reduce function file.

```

function meanArrivalDelayByDayReducer(interKey, interValIter, outKVStore)
    n = 0;
    s = 0;

    % get all sets of intermediate results
    while hasNext(interValIter)
        interValue = getNext(interValIter);
        n = n + interValue(1);
        s = s + interValue(2);
    end

    % accumulate the sum and count
    mean = s/n;
    % add results to the output datastore
    add(outKVStore,interKey,mean);
end

```

Use `mapreduce` to apply the map and reduce functions to the datastore, `ds`.

```

meanDelayByDay = mapreduce(ds, @meanArrivalDelayByDayMapper, ...
    @meanArrivalDelayByDayReducer);

```

```

*****
*      MAPREDUCE PROGRESS      *
*****
Map   0% Reduce   0%
Map  16% Reduce   0%
Map  32% Reduce   0%
Map  48% Reduce   0%
Map  65% Reduce   0%
Map  81% Reduce   0%
Map  97% Reduce   0%
Map 100% Reduce   0%
Map 100% Reduce  14%
Map 100% Reduce  29%

```

```
Map 100% Reduce 43%
Map 100% Reduce 57%
Map 100% Reduce 71%
Map 100% Reduce 86%
Map 100% Reduce 100%
```

`mapreduce` returns a datastore, `meanDelayByDay`, with files in the current folder.

Read the final result from the output datastore, `meanDelayByDay`.

```
result = readall(meanDelayByDay)
```

```
result=7x2 table
  Key      Value
  ----      -
  3      {[7.0038]}
  1      {[7.0833]}
  5      {[9.4193]}
  4      {[9.3185]}
  6      {[4.2095]}
  2      {[5.8569]}
  7      {[6.5241]}
```

Organize Results

The integer keys (1 to 7) represent the days of the week. To organize the results more, convert the keys to a categorical array, retrieve the numeric values from the single element cells, and rename the variable names of the resulting table.

```
result.Key = categorical(result.Key, 1:7, ...
    {'Mon', 'Tue', 'Wed', 'Thu', 'Fri', 'Sat', 'Sun'});
result.Value = cell2mat(result.Value);
result.Properties.VariableNames = {'DayOfWeek', 'MeanArrDelay'}
```

```
result=7x2 table
  DayOfWeek      MeanArrDelay
  ----
  Wed           7.0038
  Mon           7.0833
  Fri           9.4193
  Thu           9.3185
  Sat           4.2095
  Tue           5.8569
  Sun           6.5241
```

Sort the rows of the table by mean flight arrival delay. This reveals that Saturday is the best day of the week to travel, whereas Friday is the worst.

```
result = sortrows(result, 'MeanArrDelay')
```

```
result=7x2 table
  DayOfWeek      MeanArrDelay
  ----
  Sat           4.2095
```

Tue	5.8569
Sun	6.5241
Wed	7.0038
Mon	7.0833
Thu	9.3185
Fri	9.4193

Local Functions

Listed here are the map and reduce functions that mapreduce applies to the data.

```
function meanArrivalDelayByDayMapper(data, ~, intermKVStore)
% Data is an n-by-2 table: first column is the DayOfWeek and the second
% is the ArrDelay. Remove missing values first.
delays = data.ArrDelay;
day = data.DayOfWeek;
notNaN = ~isnan(delays);
day = day(notNaN);
delays = delays(notNaN);

% find the unique days in this chunk
[intermKeys,~,idx] = unique(day, 'stable');

% group delays by idx and apply @grpstatsfun function to each group
intermVals = accumarray(idx,delays,size(intermKeys),@countsum);
addmulti(intermKVStore,intermKeys,intermVals);

function out = countsum(x)
    n = length(x); % count
    s = sum(x); % mean
    out = {[n, s]};
end
end
%-----
function meanArrivalDelayByDayReducer(intermKey, intermValIter, outKVStore)
    n = 0;
    s = 0;

% get all sets of intermediate results
while hasNext(intermValIter)
    intermValue = getNext(intermValIter);
    n = n + intermValue(1);
    s = s + intermValue(2);
end

% accumulate the sum and count
mean = s/n;
% add results to the output datastore
add(outKVStore,intermKey,mean);
end
%-----
```

See Also

mapreduce | tabularTextDatastore

More About

- “Getting Started with MapReduce” on page 13-3
- “Build Effective Algorithms with MapReduce” on page 13-18

Create Histograms Using MapReduce

This example shows how to visualize patterns in a large data set without having to load all of the observations into memory simultaneously. It demonstrates how to compute lower volume summaries of the data that are sufficient to generate a graphic.

Histograms are a common visualization technique that give an empirical estimate of the probability density function (pdf) of a variable. Histograms are well-suited to a big data environment, because they can reduce the size of raw input data to a vector of counts. Each count is the number of observations that falls within each of a set of contiguous, numeric intervals or bins.

The `mapreduce` function computes counts separately on multiple blocks of the data. Then `mapreduce` sums the counts from all blocks. The map function and reduce function are both extremely simple in this example. Nevertheless, you can build flexible visualizations with the summary information that they collect.

Prepare Data

Create a datastore using the `airlinesmall.csv` data set. This 12-megabyte data set contains 29 columns of flight information for several airline carriers, including arrival and departure times. In this example, select `ArrDelay` (flight arrival delay) as the variable of interest.

```
ds = tabularTextDatastore('airlinesmall.csv', 'TreatAsMissing', 'NA');  
ds.SelectedVariableNames = 'ArrDelay';
```

The datastore treats 'NA' values as missing, and replaces the missing values with NaN values by default. Additionally, the `SelectedVariableNames` property allows you to work with only the selected variable of interest, which you can verify using `preview`.

```
preview(ds)  
  
ans=8x1 table  
  ArrDelay  
  _____  
         8  
         8  
        21  
        13  
         4  
        59  
         3  
        11
```

Run MapReduce

The `mapreduce` function requires a map function and a reduce function as inputs. The mapper receives blocks of data and outputs intermediate results. The reducer reads the intermediate results and produces a final result.

In this example, the mapper collects the counts of flights with various amounts of arrival delay by accumulating the arrival delays into bins. The bins are defined by the fourth input argument to the map function, `edges`.

Display the map function file.

```
function visualizationMapper(data, ~, intermKVStore, edges)
    % Count how many flights have arrival delay in each interval specified by
    % the EDGES vector, and add these counts to INTERMKVSTORE.
    counts = histc(data.ArrDelay, edges);
    add(intermKVStore, 'Null', counts);
end
```

The bin size of the histogram is important. Bins that are too wide can obscure important details in the data set. Bins that are too narrow can lead to a noisy histogram. When working with very large data sets, it is best to avoid making multiple passes over the data to try out different bin widths. A simple way to avoid making multiple passes is to collect counts with bins that are narrow. Then, to get wider bins, you can aggregate adjacent bin counts without reprocessing the raw data. The flight arrival delays are reported in 1-minute increments, so define 1-minute bins from -60 minutes to 599 minutes.

```
edges = -60:599;
```

Create an anonymous function to configure the map function to use the bin edges. The anonymous function allows you to specialize the map function by specifying a particular value for its fourth input argument. Then, you can call the map function via the anonymous function, using only the three input arguments that the `mapreduce` function expects.

```
ourVisualizationMapper = ...
    @(data, info, intermKVStore) visualizationMapper(data, info, intermKVStore, edges);
```

Display the reduce function file. The reducer sums the counts stored by the mapper.

```
function visualizationReducer(~, intermValList, outKVStore)
    if hasnext(intermValList)
        outVal = getnext(intermValList);
    else
        outVal = [];
    end
    while hasnext(intermValList)
        outVal = outVal + getnext(intermValList);
    end
    add(outKVStore, 'Null', outVal);
end
```

Use `mapreduce` to apply the map and reduce functions to the datastore, `ds`.

```
result = mapreduce(ds, ourVisualizationMapper, @visualizationReducer);
```

```
*****
*      MAPREDUCE PROGRESS      *
*****
Map   0% Reduce   0%
Map  16% Reduce   0%
Map  32% Reduce   0%
Map  48% Reduce   0%
Map  65% Reduce   0%
Map  81% Reduce   0%
Map  97% Reduce   0%
Map 100% Reduce   0%
Map 100% Reduce 100%
```

`mapreduce` returns an output datastore, `result`, with files in the current folder.

Organize Results

Read the final bin count results from the output datastore.

```
r = readall(result);  
counts = r.Value{1};
```

Visualize Results

Plot the raw bin counts using the whole range of the data (apart from a few outliers excluded by the mapper).

```
bar(edges, counts, 'hist');  
title('Distribution of Flight Delay')  
xlabel('Arrival Delay (min)')  
ylabel('Flight Counts')
```

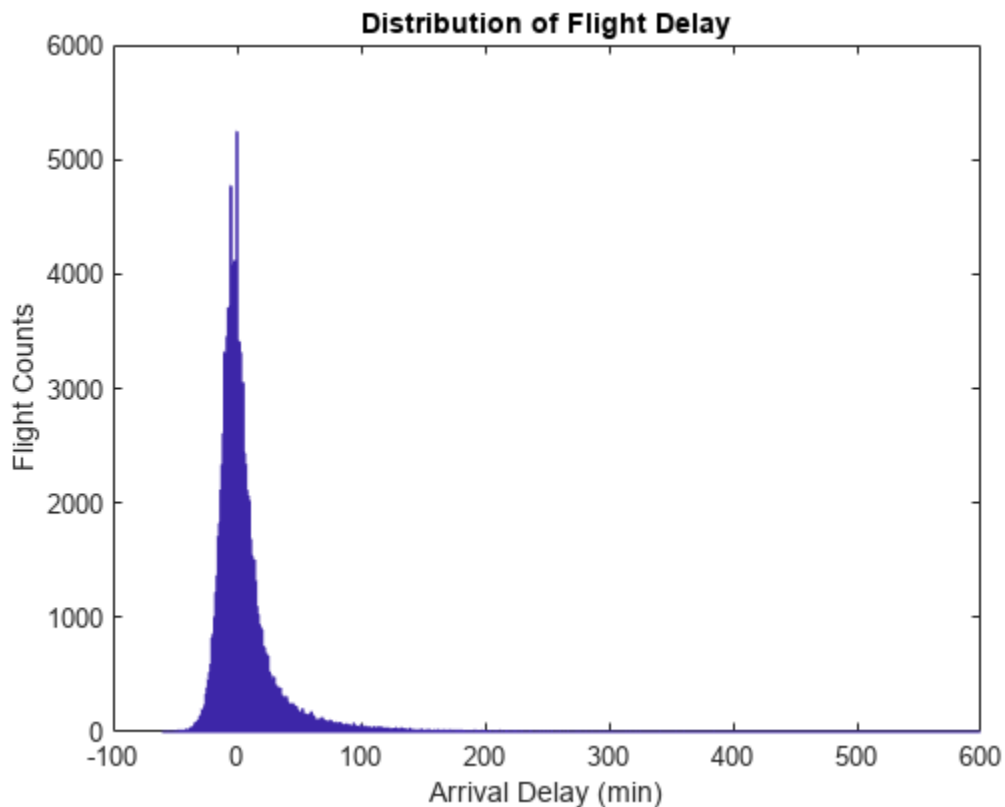

The histogram has long tails. Look at a restricted bin range to better visualize the delay distribution of the majority of flights. Zooming in a bit reveals there is a reporting artifact; it is common to round delays to 5-minute increments.

```
xlim([-50,50]);  
grid on  
grid minor
```

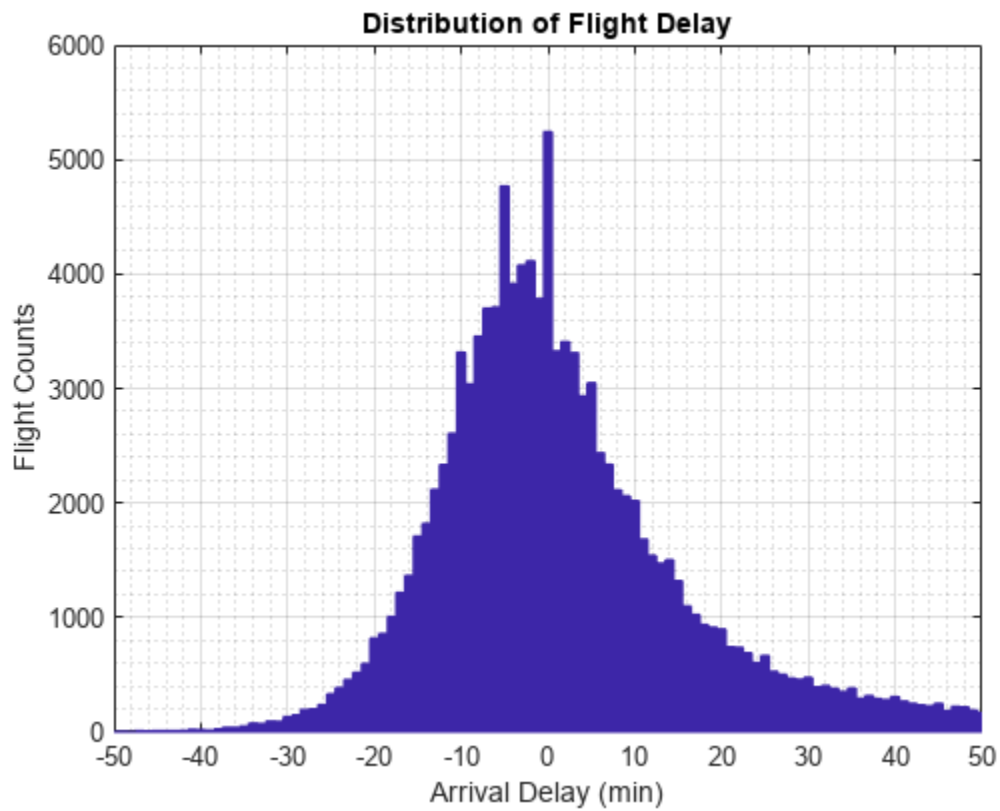

Smooth the counts with a moving average filter to remove the 5-minute recording artifact.

```
smoothCounts = filter( (1/5)*ones(1,5), 1, counts);  
figure  
bar(edges, smoothCounts, 'hist')  
xlim([-50,50]);  
title('Distribution of Flight Delay')  
xlabel('Arrival Delay (min)')  
ylabel('Flight Counts')  
grid on  
grid minor
```

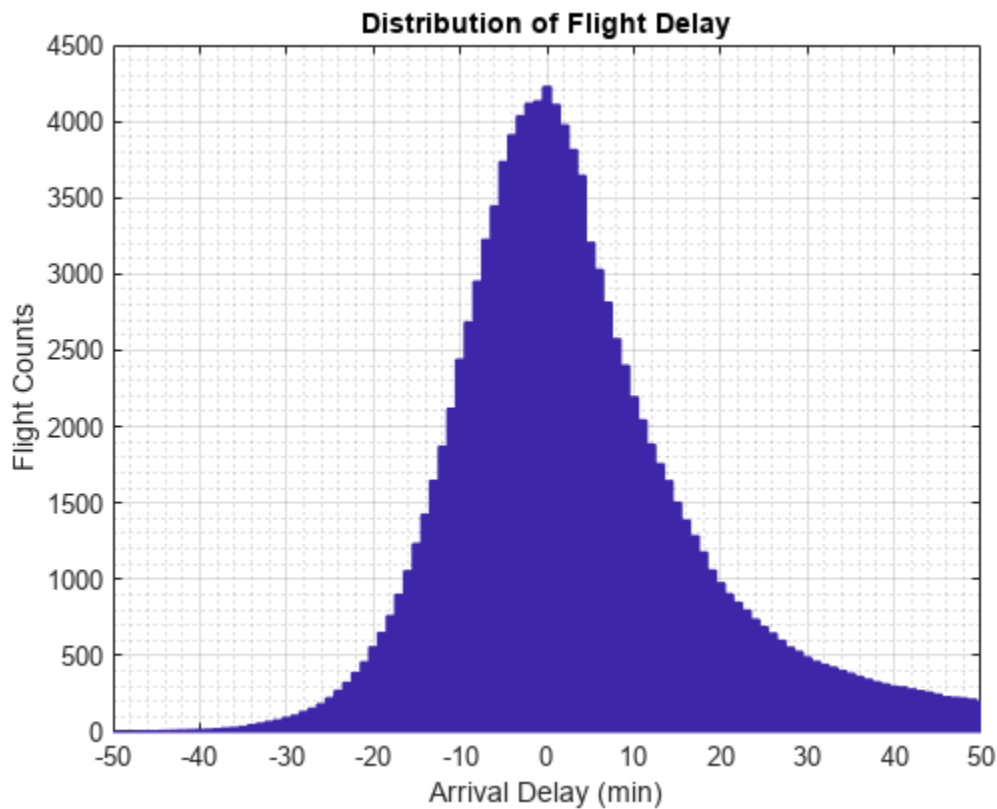

To give the graphic a better balance, do not display the top 1% of most-delayed flights. You can tailor the visualization in many ways without reprocessing the complete data set, assuming that you collected the appropriate information during the full pass through the data.

```
empiricalCDF = cumsum(counts);
empiricalCDF = empiricalCDF / empiricalCDF(end);
quartile99 = find(empiricalCDF>0.99, 1, 'first');
low99 = 1:quartile99;

figure
empiricalPDF = smoothCounts(low99) / sum(smoothCounts);
bar(edges(low99), empiricalPDF, 'hist');

xlim([-60,edges(quartile99)]);
ylim([0, max(empiricalPDF)*1.05]);
title('Distribution of Flight Delay')
xlabel('Arrival Delay (min)')
ylabel('Probability Density')
```

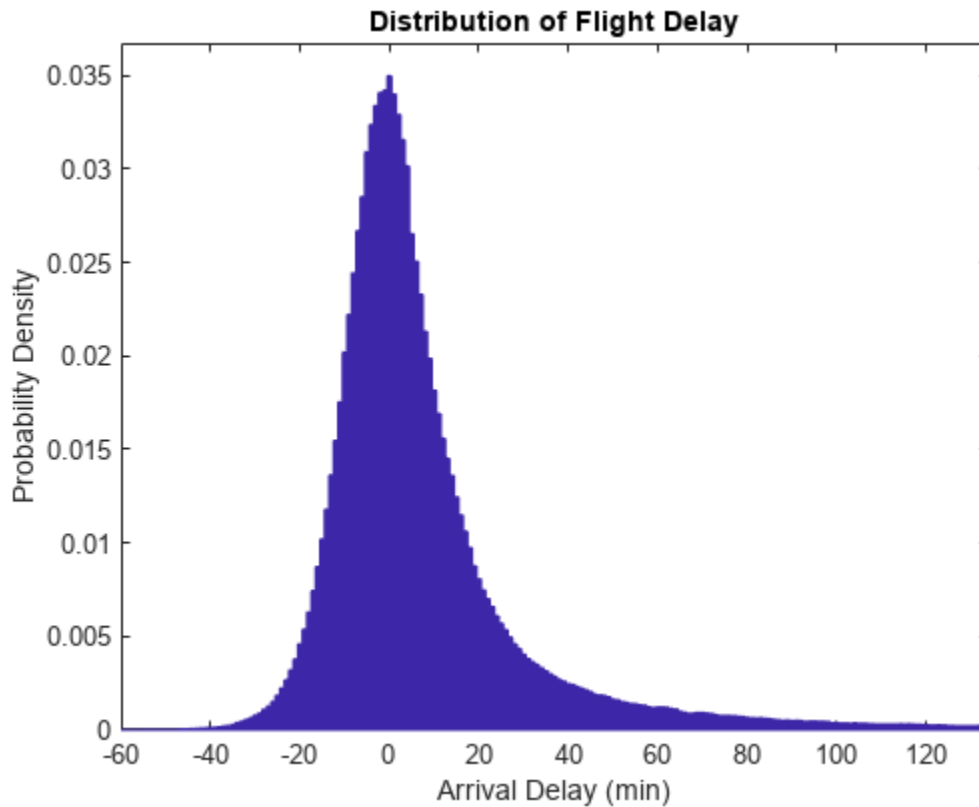

Local Functions

Listed here are the map and reduce functions that mapreduce applies to the data.

```
function visualizationMapper(data, ~, intermKVStore, edges)
    % Count how many flights have arrival delay in each interval specified by
    % the EDGES vector, and add these counts to INTERMKVSTORE.
    counts = histc(data.ArrDelay, edges);
    add(intermKVStore, 'Null', counts);
end
%-----
function visualizationReducer(~, intermValList, outKVStore)
    if hasNext(intermValList)
        outVal = getNext(intermValList);
    else
        outVal = [];
    end
    while hasNext(intermValList)
        outVal = outVal + getNext(intermValList);
    end
    add(outKVStore, 'Null', outVal);
end
%-----
```

See Also

mapreduce | tabularTextDatastore

More About

- “Getting Started with MapReduce” on page 13-3
- “Build Effective Algorithms with MapReduce” on page 13-18

Simple Data Subsetting Using MapReduce

This example shows how to extract a subset of a large data set.

There are two aspects of subsetting, or performing a query. One is selecting a subset of the variables (columns) in the data set. The other is selecting a subset of the observations, or rows.

In this example, the selection of variables takes place in the definition of the datastore. (The map function could perform a further sub-selection of variables, but that is not within the scope of this example). In this example, the role of the map function is to perform the selection of observations. The role of the reduce function is to concatenate the subsetting records extracted by each call to the map function. This approach assumes that the data set can fit in memory after the Map phase.

Prepare Data

Create a datastore using the `airlinesmall.csv` data set. This 12-megabyte data set contains 29 columns of flight information for several airline carriers, including arrival and departure times. This example uses 15 variables out of the 29 variables available in the data.

```
ds = tabularTextDatastore('airlinesmall.csv', 'TreatAsMissing', 'NA');
ds.SelectedVariableNames = ds.VariableNames([1 2 5 9 12 13 15 16 17 ...
      18 20 21 25 26 27]);
ds.SelectedVariableNames

ans = 1x15 cell
  Columns 1 through 4
    {'Year'}    {'Month'}    {'DepTime'}    {'UniqueCarrier'}

  Columns 5 through 8
    {'ActualElapsedTime'}    {'CRSElapsedTime'}    {'ArrDelay'}    {'DepDelay'}

  Columns 9 through 13
    {'Origin'}    {'Dest'}    {'TaxiIn'}    {'TaxiOut'}    {'CarrierDelay'}

  Columns 14 through 15
    {'WeatherDelay'}    {'NASDelay'}
```

The datastore treats 'NA' values as missing, and replaces the missing values with NaN values by default. Additionally, the `SelectedVariableNames` property allows you to work with only the specified variables of interest, which you can verify using `preview`.

```
preview(ds)
```

```
ans=8x15 table
  Year    Month    DepTime    UniqueCarrier    ActualElapsedTime    CRSElapsedTime    ArrDelay
  _____  _____  _____  _____  _____  _____  _____
  1987     10       642        {'PS'}           53                   57                   8
  1987     10      1021        {'PS'}           63                   56                   8
  1987     10      2055        {'PS'}           83                   82                   21
  1987     10      1332        {'PS'}           59                   58                   13
```

1987	10	629	{'PS'}	77	72	4
1987	10	1446	{'PS'}	61	65	59
1987	10	928	{'PS'}	84	79	3
1987	10	859	{'PS'}	155	143	11

Run MapReduce

The `mapreduce` function requires a map function and a reduce function as inputs. The mapper receives blocks of data and outputs intermediate results. The reducer reads the intermediate results and produces a final result.

In this example, the mapper receives a table with the variables described by the `SelectedVariableNames` property in the datastore. Then, the mapper extracts flights that had a high amount of delay after pushback from the gate. Specifically, it identifies flights with a duration exceeding 2.5 times the length of the scheduled duration. The mapper ignores flights prior to 1995, because some of the variables of interest for this example were not collected before that year.

Display the map function file.

```
function subsettingMapper(data, ~, intermKVStore)
% Select flights from 1995 and later that had exceptionally long
% elapsed flight times (including both time on the tarmac and time in
% the air).
idx = data.Year > 1994 & (data.ActualElapsedTime - data.CRSElapsedTime)...
    > 1.50 * data.CRSElapsedTime;
intermVal = data(idx,:);

add(intermKVStore, 'Null', intermVal);
end
```

The reducer receives the subsetted observations obtained from the mapper and simply concatenates them into a single table. The reducer returns one key (which is relatively meaningless) and one value (the concatenated table).

Display the reduce function file.

```
function subsettingReducer(~, intermValList, outKVStore)
% get all intermediate results from the list
outVal = {};

while hasNext(intermValList)
    outVal = [outVal; getNext(intermValList)];
end
% Note that this approach assumes the concatenated intermediate values (the
% subset of the whole data) fit in memory.

add(outKVStore, 'Null', outVal);
end
```

Use `mapreduce` to apply the map and reduce functions to the datastore, `ds`.

```
result = mapreduce(ds, @subsettingMapper, @subsettingReducer);
```

```
*****
*      MAPREDUCE PROGRESS      *
*****
Map   0% Reduce  0%
```



```

Map 16% Reduce 0%
Map 32% Reduce 0%
Map 48% Reduce 0%
Map 65% Reduce 0%
Map 81% Reduce 0%
Map 97% Reduce 0%
Map 100% Reduce 0%
Map 100% Reduce 100%

```

mapreduce returns an output datastore, `result`, with files in the current folder.

Display Results

Look for patterns in the first 10 variables that were pulled from the data set. These variables identify the airline, the destination, and the arrival airports, as well as some basic delay information.

```

r = readall(result);
tbl = r.Value{1};
tbl(:,1:10)

```

```

ans=37x10 table
   Year   Month   DepTime   UniqueCarrier   ActualElapsedTime   CRSElapsedTime   ArrDelay
   _____
   1995     6     1601     {'US'}           162                 58                118
   1996     6     1834     {'CO'}           241                 75                220
   1997     1       730     {'DL'}           110                 43                137
   1997     4     1715     {'UA'}           152                 57                243
   1997     9     2232     {'NW'}           143                 50                115
   1997    10     1419     {'CO'}           196                 58                157
   1998     3     2156     {'DL'}           139                 49                146
   1998    10     1803     {'NW'}           291                 81                213
   2000     5       830     {'WN'}           140                 55                 85
   2000     8     1630     {'CO'}           357                 123               244
   2002     6     1759     {'US'}           260                 67                192
   2003     3     1214     {'XE'}           214                 84                124
   2003     3       604     {'XE'}           175                 60                114
   2003     4     1556     {'MQ'}           142                 52                182
   2003     5     1954     {'US'}           127                 48                 78
   2003     7     1250     {'FL'}           261                 95                166
   :

```

Looking at the first record, a U.S. Air flight departed the gate 14 minutes after its scheduled departure time and arrived 118 minutes late. The flight experienced a delay of 104 minutes after pushback from the gate which is the difference between `ActualElapsedTime` and `CRSElapsedTime`.

There is one anomalous record. In February of 2006, a JetBlue flight had a departure time of 3:24 a.m. and an elapsed flight time of 1650 minutes, but an arrival delay of only 415 minutes. This might be a data entry error.

Otherwise, there are no clear cut patterns concerning when and where these exceptionally delayed flights occur. No airline, time of year, time of day, or single airport dominates. Some intuitive patterns, such as O'Hare (ORD) in the winter months, are certainly present.

Delay Patterns

Beginning in 1995, the airline system performance data began including measurements of how much delay took place in the taxi phases of a flight. Then, in 2003, the data also began to include certain causes of delay.

Examine these two variables in closer detail.

```
tbl(:, [1,7,8,11:end])
```

```
ans=37x8 table
```

Year	ArrDelay	DepDelay	TaxiIn	TaxiOut	CarrierDelay	WeatherDelay	NASDelay
1995	118	14	7	101	NaN	NaN	NaN
1996	220	54	12	180	NaN	NaN	NaN
1997	137	70	2	12	NaN	NaN	NaN
1997	243	148	4	38	NaN	NaN	NaN
1997	115	22	4	98	NaN	NaN	NaN
1997	157	19	6	95	NaN	NaN	NaN
1998	146	56	9	47	NaN	NaN	NaN
1998	213	3	11	205	NaN	NaN	NaN
2000	85	0	5	51	NaN	NaN	NaN
2000	244	10	4	273	NaN	NaN	NaN
2002	192	-1	6	217	NaN	NaN	NaN
2003	124	-6	13	131	NaN	NaN	NaN
2003	114	-1	8	106	NaN	NaN	NaN
2003	182	92	9	106	NaN	NaN	NaN
2003	78	-1	5	90	NaN	NaN	NaN
2003	166	0	11	170	0	0	166
:							

For these exceptionally delayed flights, the great majority of delay occurs during taxi out, on the tarmac. Moreover, the major cause of the delay is *NASDelay*. NAS delays are holds imposed by the national aviation authorities on departures headed for an airport that is forecast to be unable to handle all scheduled arrivals at the time the flight is scheduled to arrive. NAS delay programs in effect at any given time are posted at <https://nasstatus.faa.gov/>.

Preferably, when NAS delays are imposed, boarding of the aircraft is simply delayed. Such a delay would show up as a departure delay. However, for most of the flights selected for this example, the delays took place largely after departure from the gate, leading to a taxi delay.

Rerun MapReduce

The previous map function had the subsetting criteria hard-wired in the function file. A new map function would have to be written for any new query, such as flights departing San Francisco on a given day.

A generic mapper can be more adaptive by separating out the subsetting criteria from the map function definition and using an anonymous function to configure the mapper for each query. This generic mapper uses a fourth input argument that supplies the desired query variable.

Display the generic map function file.

```
function subsettingMapperGeneric(data, ~, intermKVStore, subsetter)
    intermKey = 'Null';
```

```

    intermVal = data(subsetter(data), :);
    add(intermKVStore, intermKey, intermVal);
end

```

Create an anonymous function that performs the same selection of rows that is hard-coded in `subsettingMapper`.

```

inFlightDelay150percent = ...
@(data) data.Year > 1994 & ...
(data.ActualElapsedTime-data.CRSElapsedTime) > 1.50*data.CRSElapsedTime;

```

Since the `mapreduce` function requires the map and reduce functions to accept exactly three inputs, use another anonymous function to specify the fourth input to the mapper, `subsettingMapperGeneric`. Subsequently, you can use this anonymous function to call `subsettingMapperGeneric` using only three arguments (the fourth is implicit).

```

configuredMapper = ...
@(data, info, intermKVStore) subsettingMapperGeneric(data, info, ...
    intermKVStore, inFlightDelay150percent);

```

Use `mapreduce` to apply the generic map function to the input datastore.

```

result2 = mapreduce(ds, configuredMapper, @subsettingReducer);

```

```

*****
*      MAPREDUCE PROGRESS      *
*****
Map   0% Reduce   0%
Map  16% Reduce   0%
Map  32% Reduce   0%
Map  48% Reduce   0%
Map  65% Reduce   0%
Map  81% Reduce   0%
Map  97% Reduce   0%
Map 100% Reduce   0%
Map 100% Reduce 100%

```

`mapreduce` returns an output datastore, `result2`, with files in the current folder.

Verify Results

Confirm that the generic mapper gets the same result as with the hard-wired subsetting logic.

```

r2 = readall(result2);
tbl2 = r2.Value{1};

if isequaln(tbl, tbl2)
    disp('Same results with the configurable mapper.')
else
    disp('Oops, back to the drawing board.')
end

```

Same results with the configurable mapper.

Local Functions

Listed here are the map and reduce functions that `mapreduce` applies to the data.

```

function subsettingMapper(data, ~, intermKVStore)
    % Select flights from 1995 and later that had exceptionally long

```

```
% elapsed flight times (including both time on the tarmac and time in
% the air).
idx = data.Year > 1994 & (data.ActualElapsedTime - data.CRSElapsedTime)...
    > 1.50 * data.CRSElapsedTime;
intermVal = data(idx,:);

add(intermKVStore, 'Null', intermVal);
end
%-----
function subsettingReducer(~, intermValList, outKVStore)
% get all intermediate results from the list
outVal = {};

while hasNext(intermValList)
    outVal = [outVal; getNext(intermValList)];
end
% Note that this approach assumes the concatenated intermediate values (the
% subset of the whole data) fit in memory.

add(outKVStore, 'Null', outVal);
end
%-----
function subsettingMapperGeneric(data, ~, intermKVStore, subsetter)
    intermKey = 'Null';
    intermVal = data(subsetter(data), :);
    add(intermKVStore, intermKey, intermVal);
end
%-----
```

See Also

mapreduce | tabularTextDatastore

More About

- “Getting Started with MapReduce” on page 13-3
- “Build Effective Algorithms with MapReduce” on page 13-18

Using MapReduce to Compute Covariance and Related Quantities

This example shows how to compute the mean and covariance for several variables in a large data set using mapreduce. It then uses the covariance to perform several follow-up calculations that do not require another iteration over the entire data set.

Prepare Data

Create a datastore using the `airlinesmall.csv` data set. This 12-megabyte data set contains 29 columns of flight information for several airline carriers, including arrival and departure times. In this example, select `ActualElapsedTime` (total flight time), `Distance` (total flight distance), `DepDelay` (flight departure delay), and `ArrDelay` (flight arrival delay) as the variables of interest.

```
ds = tabularTextDatastore('airlinesmall.csv', 'TreatAsMissing', 'NA');
ds.SelectedVariableNames = {'ActualElapsedTime', 'Distance', ...
                           'DepDelay', 'ArrDelay'};
```

The datastore treats 'NA' values as missing, and replaces the missing values with NaN values by default. Additionally, the `SelectedVariableNames` property allows you to work with only the selected variables of interest, which you can verify using `preview`.

```
preview(ds)
```

```
ans=8x4 table
   ActualElapsedTime   Distance   DepDelay   ArrDelay
   _____   _____   _____   _____
           53           308           12           8
           63           296            1           8
           83           480           20          21
           59           296           12          13
           77           373            -1           4
           61           308           63          59
           84           447            -2           3
          155           954            -1          11
```

Run MapReduce

The `mapreduce` function requires a map function and a reduce function as inputs. The mapper receives blocks of data and outputs intermediate results. The reducer reads the intermediate results and produces a final result.

In this example, the mapper computes the count, mean, and covariance for the variables in each block of data in the datastore, `ds`. Then, the mapper stores the computed values for each block as an intermediate key-value pair consisting of a single key with a cell array containing the three computed values.

Display the map function file.

```
function covarianceMapper(t,~,intermKVStore)
    % Get data from input table and remove any rows with missing values
    x = t{:, :};
    x = x(~any(isnan(x),2),:);
```

```

% Compute and save the count, mean, and covariance
n = size(x,1);
m = mean(x,1);
c = cov(x,1);

% Store values as a single item in the intermediate key/value store
add(intermKVStore,'key',{n m c})
end

```

The reducer combines the intermediate results for each block to obtain the count, mean, and covariance for each variable of interest in the entire data set. The reducer stores the final key-value pairs for the keys 'count', 'mean', and 'cov' with the corresponding values for each variable.

Display the reduce function file.

```

function covarianceReducer(~,intermValIter,outKVStore)
% We will combine results computed in the mapper for different chunks of
% the data, updating the count, mean, and covariance each time we add a new
% chunk.

% First, initialize everything to zero (scalar 0 is okay)
n1 = 0; % no rows so far
m1 = 0; % mean so far
c1 = 0; % covariance so far

while hasNext(interValIter)
% Get the next chunk, and extract the count, mean, and covariance
t = getNext(interValIter);
n2 = t{1};
m2 = t{2};
c2 = t{3};

% Use weighting formulas to update the values so far
n = n1+n2; % new count
m = (n1*m1 + n2*m2) / n; % new mean

% New covariance is a weighted combination of the two covariance, plus
% additional terms that relate to the difference in means
c1 = (n1*c1 + n2*c2 + n1*(m1-m)*(m1-m) + n2*(m2-m)*(m2-m))/ n;

% Store the new mean and count for the next iteration
m1 = m;
n1 = n;
end

% Save results in the output key/value store
add(outKVStore,'count',n1);
add(outKVStore,'mean',m1);
add(outKVStore,'cov',c1);
end

```

Use mapreduce to apply the map and reduce functions to the datastore, ds.

```

outds = mapreduce(ds, @covarianceMapper, @covarianceReducer);

```

```

*****
*      MAPREDUCE PROGRESS      *

```

```
*****
Map  0% Reduce  0%
Map 16% Reduce  0%
Map 32% Reduce  0%
Map 48% Reduce  0%
Map 65% Reduce  0%
Map 81% Reduce  0%
Map 97% Reduce  0%
Map 100% Reduce  0%
Map 100% Reduce 100%
```

`mapreduce` returns a datastore, `outds`, with files in the current folder.

View the results of the `mapreduce` call by using the `readall` function on the output datastore.

```
results = readall(outds)
```

```
results=3x2 table
      Key                               Value
-----
{'count'}  {[                               120664]}
{'mean' }  {[120.2452 703.3926 8.1334 7.1235]}
{'cov' }   {4x4 double }
```

```
Count = results.Value{1};
MeanVal = results.Value{2};
Covariance = results.Value{3};
```

Compute Correlation Matrix

The covariance, mean, and count values are useful to perform further calculations. Compute a correlation matrix by finding the standard deviations and normalizing them to correlation form.

```
s = sqrt(diag(Covariance));
Correlation = Covariance ./ (s*s')
```

```
Correlation = 4x4

    1.0000    0.9666    0.0278    0.0902
    0.9666    1.0000    0.0216    0.0013
    0.0278    0.0216    1.0000    0.8748
    0.0902    0.0013    0.8748    1.0000
```

The elapsed time (first column) and distance (second column) are highly correlated, since $\text{Correlation}(2,1) = 0.9666$. The departure delay (third column) and arrival delay (fourth column) are also highly correlated, since $\text{Correlation}(4,3) = 0.8748$.

Compute Regression Coefficients

Compute some regression coefficients to predict the arrival delay, `ArrDelay`, using the other three variables as predictors.

```
slopes = Covariance(1:3,1:3)\Covariance(1:3,4);
intercept = MeanVal(4) - MeanVal(1:3)*slopes;
b = table([intercept; slopes], 'VariableNames', {'Estimate'}, ...
         'RowNames', {'Intercept', 'ActualElapsedTime', 'Distance', 'DepDelay'})
```

```

b=4x1 table

                Estimate
-----
Intercept      -19.912
ActualElapsedTime  0.56278
Distance       -0.068721
DepDelay        0.94689

```

Perform PCA

Use `svd` to perform PCA (principal components analysis). PCA is a technique for finding a lower dimensional summary of a data set. The following calculation is a simplified version of PCA, but more options are available from the `pca` and `pcacov` functions in Statistics and Machine Learning Toolbox™.

You can carry out PCA using either the covariance or correlation. In this case, use the correlation since the difference in scale of the variables is large. The first two components capture most of the variance.

```

[~,latent,pcacoeff] = svd(Correlation);
latent = diag(latent)

```

```

latent = 4x1

    2.0052
    1.8376
    0.1407
    0.0164

```

Display the coefficient matrix. Each column of the coefficients matrix describes how one component is defined as a linear combination of the standardized original variables. The first component is mostly an average of the first two variables, with some additional contribution from the other variables. Similarly, the second component is mostly an average of the last two variables.

```

pcacoeff

pcacoeff = 4x4

   -0.6291    0.3222   -0.2444   -0.6638
   -0.6125    0.3548    0.2591    0.6572
   -0.3313   -0.6244    0.6673   -0.2348
   -0.3455   -0.6168   -0.6541    0.2689

```

Local Functions

Listed here are the map and reduce functions that `mapreduce` applies to the data.

```

function covarianceMapper(t,~,intermKVStore)
% Get data from input table and remove any rows with missing values
x = t{:, :};
x = x(~any(isnan(x),2), :);

% Compute and save the count, mean, and covariance
n = size(x,1);

```



```

m = mean(x,1);
c = cov(x,1);

% Store values as a single item in the intermediate key/value store
add(intermKVStore,'key',{n m c})
end
%-----
function covarianceReducer(~,intermValIter,outKVStore)
% We will combine results computed in the mapper for different chunks of
% the data, updating the count, mean, and covariance each time we add a new
% chunk.

% First, initialize everything to zero (scalar 0 is okay)
n1 = 0; % no rows so far
m1 = 0; % mean so far
c1 = 0; % covariance so far

while hasNext(interValIter)
% Get the next chunk, and extract the count, mean, and covariance
t = getNext(interValIter);
n2 = t{1};
m2 = t{2};
c2 = t{3};

% Use weighting formulas to update the values so far
n = n1+n2; % new count
m = (n1*m1 + n2*m2) / n; % new mean

% New covariance is a weighted combination of the two covariance, plus
% additional terms that relate to the difference in means
c1 = (n1*c1 + n2*c2 + n1*(m1-m)*(m1-m) + n2*(m2-m)*(m2-m))/ n;

% Store the new mean and count for the next iteration
m1 = m;
n1 = n;
end

% Save results in the output key/value store
add(outKVStore,'count',n1);
add(outKVStore,'mean',m1);
add(outKVStore,'cov',c1);
end
%-----

```

See Also

mapreduce | tabularTextDatastore

More About

- “Getting Started with MapReduce” on page 13-3
- “Build Effective Algorithms with MapReduce” on page 13-18

Compute Summary Statistics by Group Using MapReduce

This example shows how to compute summary statistics organized by group using `mapreduce`. It demonstrates the use of an anonymous function to pass an extra grouping parameter to a parameterized map function. This parameterization allows you to quickly recalculate the statistics using a different grouping variable.

Prepare Data

Create a datastore using the `airlinesmall.csv` data set. This 12-megabyte data set contains 29 columns of flight information for several airline carriers, including arrival and departure times. For this example, select `Month`, `UniqueCarrier` (airline carrier ID), and `ArrDelay` (flight arrival delay) as the variables of interest.

```
ds = tabularTextDatastore('airlinesmall.csv', 'TreatAsMissing', 'NA');
ds.SelectedVariableNames = {'Month', 'UniqueCarrier', 'ArrDelay'};
```

The datastore treats 'NA' values as missing, and replaces the missing values with NaN values by default. Additionally, the `SelectedVariableNames` property allows you to work with only the selected variables of interest, which you can verify using `preview`.

```
preview(ds)
```

```
ans=8x3 table
      Month UniqueCarrier ArrDelay
      _____ _____ _____
      10      {'PS'}          8
      10      {'PS'}          8
      10      {'PS'}         21
      10      {'PS'}         13
      10      {'PS'}          4
      10      {'PS'}         59
      10      {'PS'}          3
      10      {'PS'}         11
```

Run MapReduce

The `mapreduce` function requires a map function and a reduce function as inputs. The mapper receives blocks of data and outputs intermediate results. The reducer reads the intermediate results and produces a final result.

In this example, the mapper computes the grouped statistics for each block of data and stores the statistics as intermediate key-value pairs. Each intermediate key-value pair has a key for the group level and a cell array of values with the corresponding statistics.

This map function accepts four input arguments, whereas the `mapreduce` function requires the map function to accept exactly three input arguments. The call to `mapreduce` (below) shows how to pass in this extra parameter.

Display the map function file.

```
function statsByGroupMapper(data, ~, intermKVStore, groupVarName)
    % Data is a n-by-3 table. Remove missing values first
```

```

delays = data.ArrDelay;
groups = data.(groupVarName);
notNaN = ~isnan(delays);
groups = groups(notNaN);
delays = delays(notNaN);

% Find the unique group levels in this chunk
[intermKeys,~,idx] = unique(groups, 'stable');

% Group delays by idx and apply @grpstatsfun function to each group
intermVals = accumarray(idx,delays,size(interKeys),@grpstatsfun);
addmulti(interKVStore,intermKeys,intermVals);

function out = grpstatsfun(x)
    n = length(x); % count
    m = sum(x)/n; % mean
    v = sum((x-m).^2)/n; % variance
    s = sum((x-m).^3)/n; % skewness without normalization
    k = sum((x-m).^4)/n; % kurtosis without normalization
    out = {[n, m, v, s, k]};
end
end

```

After the Map phase, `mapreduce` groups the intermediate key-value pairs by unique key (in this case, the airline carrier ID), so each call to the reduce function works on the values associated with one airline. The reducer receives a list of the intermediate statistics for the airline specified by the input key (`intermKey`) and combines the statistics into separate vectors: `n`, `m`, `v`, `s`, and `k`. Then, the reducer uses these vectors to calculate the count, mean, variance, skewness, and kurtosis for a single airline. The final key is the airline carrier code, and the associated values are stored in a structure with five fields.

Display the reduce function file.

```

function statsByGroupReducer(interKey, interValIter, outKVStore)
    n = [];
    m = [];
    v = [];
    s = [];
    k = [];

    % Get all sets of intermediate statistics
    while hasNext(interValIter)
        value = getNext(interValIter);
        n = [n; value(1)];
        m = [m; value(2)];
        v = [v; value(3)];
        s = [s; value(4)];
        k = [k; value(5)];
    end
    % Note that this approach assumes the concatenated intermediate values fit
    % in memory. Refer to the reducer function, covarianceReducer, of the
    % CovarianceMapReduceExample for an alternative pairwise reduction approach

    % Combine the intermediate results
    count = sum(n);
    meanVal = sum(n.*m)/count;
    d = m - meanVal;

```

```

variance = (sum(n.*v) + sum(n.*d.^2))/count;
skewnessVal = (sum(n.*s) + sum(n.*d.*(3*v + d.^2)))/(count*variance^(1.5));
kurtosisVal = (sum(n.*k) + sum(n.*d.*(4*s + 6.*v.*d + d.^3)))/(count*variance^2);

outValue = struct('Count',count, 'Mean',meanVal, 'Variance',variance,...
                 'Skewness',skewnessVal, 'Kurtosis',kurtosisVal);

% Add results to the output datastore
add(outKVStore,intermKey,outValue);
end

```

Use `mapreduce` to apply the map and reduce functions to the datastore, `ds`. Since the parameterized map function accepts four inputs, use an anonymous function to pass in the airline carrier IDs as the fourth input.

```

outds1 = mapreduce(ds, ...
    @(data,info,kvs)statsByGroupMapper(data,info,kvs,'UniqueCarrier'), ...
    @statsByGroupReducer);

```

```

*****
*           MAPREDUCE PROGRESS           *
*****
Map   0% Reduce   0%
Map  16% Reduce   0%
Map  32% Reduce   0%
Map  48% Reduce   0%
Map  65% Reduce   0%
Map  81% Reduce   0%
Map  97% Reduce   0%
Map 100% Reduce   0%
Map 100% Reduce  10%
Map 100% Reduce  21%
Map 100% Reduce  31%
Map 100% Reduce  41%
Map 100% Reduce  52%
Map 100% Reduce  62%
Map 100% Reduce  72%
Map 100% Reduce  83%
Map 100% Reduce  93%
Map 100% Reduce 100%

```

`mapreduce` returns a datastore, `outds1`, with files in the current folder.

Read the final results from the output datastore.

```
r1 = readall(outds1)
```

```

r1=29x2 table
      Key          Value
      ----          -
      {'PS'   }    {1x1 struct}
      {'TW'   }    {1x1 struct}
      {'UA'   }    {1x1 struct}
      {'WN'   }    {1x1 struct}
      {'EA'   }    {1x1 struct}
      {'HP'   }    {1x1 struct}
      {'NW'   }    {1x1 struct}

```

```
{'PA (1)'} {1x1 struct}
{'PI'     } {1x1 struct}
{'CO'     } {1x1 struct}
{'DL'     } {1x1 struct}
{'AA'     } {1x1 struct}
{'US'     } {1x1 struct}
{'AS'     } {1x1 struct}
{'ML (1)'} {1x1 struct}
{'AQ'     } {1x1 struct}
⋮
```

Organize Results

To organize the results better, convert the structure containing the statistics into a table and use the carrier IDs as the row names. `mapreduce` returns the key-value pairs in the same order as they were added by the reduce function, so sort the table by carrier ID.

```
statsByCarrier = struct2table(cell2mat(r1.Value), 'RowNames', r1.Key);
statsByCarrier = sortrows(statsByCarrier, 'RowNames')
```

```
statsByCarrier=29x5 table
      Count      Mean      Variance      Skewness      Kurtosis
      -----
    9E         507      5.3669      1889.5        6.2676        61.706
    AA        14578      6.9598         1123        6.0321        93.085
    AQ         153       1.0065        230.02        3.9905        28.383
    AS         2826      8.0771         717         3.6547        24.083
    B6          793      11.936       2087.4        4.0072         27.45
    CO         7999       7.048       1053.8        4.6601        41.038
    DH          673       7.575       1491.7        2.9929        15.461
    DL        16284      7.4971       697.48        4.4746        41.115
    EA          875      8.2434       1221.3        5.2955        43.518
    EV         1655      10.028       1325.4        2.9347        14.878
    F9          332      8.4849       1138.6        4.2983        30.742
    FL         1248      9.5144       1360.4        3.6277        21.866
    HA          271     -1.5387        323.27        8.4245        109.63
    HP         3597       7.5897        744.51        5.2534        50.004
    ML (1)         69      0.15942       169.32        2.8354        16.559
    MQ         3805      8.8591       1530.5         7.054         105.51
    ⋮
```

Change Grouping Parameter

The use of an anonymous function to pass in the grouping variable allows you to quickly recalculate the statistics with a different grouping.

For this example, recalculate the statistics and group the results by `Month`, instead of by the carrier IDs, by simply passing the `Month` variable into the anonymous function.

```
outds2 = mapreduce(ds, ...
    @(data,info,kvs)statsByGroupMapper(data,info,kvs,'Month'), ...
    @statsByGroupReducer);
```

```
*****
*      MAPREDUCE PROGRESS      *
```

```
*****
```

```
Map 0% Reduce 0%
Map 16% Reduce 0%
Map 32% Reduce 0%
Map 48% Reduce 0%
Map 65% Reduce 0%
Map 81% Reduce 0%
Map 97% Reduce 0%
Map 100% Reduce 0%
Map 100% Reduce 17%
Map 100% Reduce 33%
Map 100% Reduce 50%
Map 100% Reduce 67%
Map 100% Reduce 83%
Map 100% Reduce 100%
```

Read the final results and organize them into a table.

```
r2 = readall(outds2);
r2 = sortrows(r2, 'Key');
statsByMonth = struct2table(cell2mat(r2.Value));
mon = {'Jan', 'Feb', 'Mar', 'Apr', 'May', 'Jun', ...
       'Jul', 'Aug', 'Sep', 'Oct', 'Nov', 'Dec'};
statsByMonth.Properties.RowNames = mon
```

```
statsByMonth=12x5 table
          Count      Mean      Variance      Skewness      Kurtosis
          -----
Jan      9870      8.5954      973.69      4.1142      35.152
Feb      9160      7.3275      911.14      4.7241      45.03
Mar     10219      7.5536      976.34      5.1678      63.155
Apr      9949      6.0081      1077.4      8.9506      170.52
May     10180      5.2949      737.09      4.0535      30.069
Jun     10045      10.264      1266.1      4.8777      43.5
Jul     10340      8.7797      1069.7      5.1428      64.896
Aug     10470      7.4522      908.64      4.1959      29.66
Sep      9691      3.6308      664.22      4.6573      38.964
Oct     10590      4.6059      684.94      5.6407      74.805
Nov     10071      5.2835      808.65      8.0297      186.68
Dec     10281      10.571      1087.6      3.8564      28.823
```

Local Functions

Listed here are the map and reduce functions that mapreduce applies to the data.

```
function statsByGroupMapper(data, ~, intermKVStore, groupVarName)
    % Data is a n-by-3 table. Remove missing values first
    delays = data.ArrDelay;
    groups = data.(groupVarName);
    notNaN = ~isnan(delays);
    groups = groups(notNaN);
    delays = delays(notNaN);

    % Find the unique group levels in this chunk
    [intermKeys,~,idx] = unique(groups, 'stable');
```

```

% Group delays by idx and apply @grpstatsfun function to each group
intermVals = accumarray(idx,delays,size(intermKeys),@grpstatsfun);
addmulti(intermKVStore,intermKeys,intermVals);

function out = grpstatsfun(x)
    n = length(x); % count
    m = sum(x)/n; % mean
    v = sum((x-m).^2)/n; % variance
    s = sum((x-m).^3)/n; % skewness without normalization
    k = sum((x-m).^4)/n; % kurtosis without normalization
    out = {[n, m, v, s, k]};
end
end
%-----
function statsByGroupReducer(intermKey, intermValIter, outKVStore)
    n = [];
    m = [];
    v = [];
    s = [];
    k = [];

    % Get all sets of intermediate statistics
    while hasNext(intermValIter)
        value = getNext(intermValIter);
        n = [n; value(1)];
        m = [m; value(2)];
        v = [v; value(3)];
        s = [s; value(4)];
        k = [k; value(5)];
    end
    % Note that this approach assumes the concatenated intermediate values fit
    % in memory. Refer to the reducer function, covarianceReducer, of the
    % CovarianceMapReduceExample for an alternative pairwise reduction approach

    % Combine the intermediate results
    count = sum(n);
    meanVal = sum(n.*m)/count;
    d = m - meanVal;
    variance = (sum(n.*v) + sum(n.*d.^2))/count;
    skewnessVal = (sum(n.*s) + sum(n.*d.*(3*v + d.^2)))./(count*variance^(1.5));
    kurtosisVal = (sum(n.*k) + sum(n.*d.*(4*s + 6.*v.*d + d.^3)))./(count*variance^2);

    outValue = struct('Count',count, 'Mean',meanVal, 'Variance',variance,...
        'Skewness',skewnessVal, 'Kurtosis',kurtosisVal);

    % Add results to the output datastore
    add(outKVStore,intermKey,outValue);
end
%-----

```

See Also

mapreduce | tabularTextDatastore

More About

- “Getting Started with MapReduce” on page 13-3

- “Build Effective Algorithms with MapReduce” on page 13-18

Using MapReduce to Fit a Logistic Regression Model

This example shows how to use `mapreduce` to carry out simple logistic regression using a single predictor. It demonstrates chaining multiple `mapreduce` calls to carry out an iterative algorithm. Since each iteration requires a separate pass through the data, an anonymous function passes information from one iteration to the next to supply information directly to the mapper.

Prepare Data

Create a datastore using the `airlinesmall.csv` data set. This 12-megabyte data set contains 29 columns of flight information for several airline carriers, including arrival and departure times. In this example, the variables of interest are `ArrDelay` (flight arrival delay) and `Distance` (total flight distance).

```
ds = tabularTextDatastore('airlinesmall.csv', 'TreatAsMissing', 'NA');
ds.SelectedVariableNames = {'ArrDelay', 'Distance'};
```

The datastore treats 'NA' values as missing, and replaces the missing values with NaN values by default. Additionally, the `SelectedVariableNames` property allows you to work with only the specified variables of interest, which you can verify using `preview`.

```
preview(ds)
```

```
ans=8x2 table
   ArrDelay   Distance
   _____  _____
         8         308
         8         296
        21         480
        13         296
         4         373
        59         308
         3         447
        11         954
```

Perform Logistic Regression

Logistic regression is a way to model the probability of an event as a function of another variable. In this example, logistic regression models the probability of a flight being more than 20 minutes late as a function of the flight distance, in thousands of miles.

To accomplish this logistic regression, the map and reduce functions must collectively perform a weighted least-squares regression based on the current coefficient values. The mapper computes a weighted sum of squares and cross product for each block of input data.

Display the map function file.

```
function logitMapper(b,t,~,intermKVStore)
    % Get data input table and remove any rows with missing values
    y = t.ArrDelay;
    x = t.Distance;
    t = ~isnan(x) & ~isnan(y);
    y = y(t)>20;           % late by more than 20 min
```

```

x = x(t)/1000;                % distance in thousands of miles

% Compute the linear combination of the predictors, and the estimated mean
% probabilities, based on the coefficients from the previous iteration
if ~isempty(b)
    % Compute xb as the linear combination using the current coefficient
    % values, and derive mean probabilities mu from them
    xb = b(1)+b(2)*x;
    mu = 1./(1+exp(-xb));
else
    % This is the first iteration. Compute starting values for mu that are
    % 1/4 if y=0 and 3/4 if y=1. Derive xb values from them.
    mu = (y+.5)/2;
    xb = log(mu./(1-mu));
end

% To perform weighted least squares, compute a sum of squares and cross
% products matrix:
%  $(X' * W * X) = (X1' * W1 * X1) + (X2' * W2 * X2) + \dots + (Xn' * Wn * Xn)$ ,
% where  $X = [X1; X2; \dots; Xn]$  and  $W = [W1; W2; \dots; Wn]$ .
%
% The mapper receives one chunk at a time and computes one of the terms on
% the right hand side. The reducer adds all of the terms to get the
% quantity on the left hand side, and then performs the regression.
w = (mu.*(1-mu));           % weights
z = xb + (y - mu) .* 1./w;  % adjusted response

X = [ones(size(x)),x,z];    % matrix of unweighted data
wss = X' * bsxfun(@times,w,X); % weighted cross-products  $X1' * W1 * X1$ 

% Store the results for this part of the data.
add(intermKVStore, 'key', wss);
end

```

The reducer computes the regression coefficient estimates from the sums of squares and cross products.

Display the reduce function file.

```

function logitReducer(~,intermValIter,outKVStore)
% We will operate over chunks of the data, updating the count, mean, and
% covariance each time we add a new chunk
old = 0;

% We want to perform weighted least squares. We do this by computing a sum
% of squares and cross products matrix
%  $M = (X' * W * X) = (X1' * W1 * X1) + (X2' * W2 * X2) + \dots + (Xn' * Wn * Xn)$ 
% where  $X = [X1; X2; \dots; Xn]$  and  $W = [W1; W2; \dots; Wn]$ .
%
% The mapper has computed the terms on the right hand side. Here in the
% reducer we just add them up.

while hasNext(interValIter)
    new = getNext(interValIter);
    old = old+new;
end
M = old; % the value on the left hand side

```

```

% Compute coefficients estimates from M. M is a matrix of sums of squares
% and cross products for [X Y] where X is the design matrix including a
% constant term and Y is the adjusted response for this iteration. In other
% words, Y has been included as an additional column of X. First we
% separate them by extracting the X'*W*X part and the X'*W*Y part.
XtWX = M(1:end-1,1:end-1);
XtWY = M(1:end-1,end);

% Solve the normal equations.
b = XtWX\XtWY;

% Return the vector of coefficient estimates.
add(outKVStore, 'key', b);
end

```

Run MapReduce

Run mapreduce iteratively by enclosing the calls to mapreduce in a loop. The loop runs until the convergence criteria are met, with a maximum of five iterations.

```

% Define the coefficient vector, starting as empty for the first iteration.
b = [];

for iteration = 1:5
    b_old = b;
    iteration

    % Here we will use an anonymous function as our mapper. This function
    % definition includes the value of b computed in the previous
    % iteration.
    mapper = @(t,ignore,intermKVStore) logitMapper(b,t,ignore,intermKVStore);
    result = mapreduce(ds, mapper, @logitReducer, 'Display', 'off');

    tbl = readall(result);
    b = tbl.Value{1}

    % Stop iterating if we have converged.
    if ~isempty(b_old) && ...
        ~any(abs(b-b_old) > 1e-6 * abs(b_old))
        break
    end
end

iteration = 1

b = 2×1

    -1.7674
     0.1209

iteration = 2

b = 2×1

    -1.8327
     0.1807

```

```
iteration = 3
```

```
b = 2×1
```

```
-1.8331  
0.1806
```

```
iteration = 4
```

```
b = 2×1
```

```
-1.8331  
0.1806
```

View Results

Use the resulting regression coefficient estimates to plot a probability curve. This curve shows the probability of a flight being more than 20 minutes late as a function of the flight distance.

```
xx = linspace(0,4000);  
yy = 1./(1+exp(-b(1)-b(2)*(xx/1000)));  
plot(xx,yy);  
xlabel('Distance');  
ylabel('Prob[Delay>20]')
```

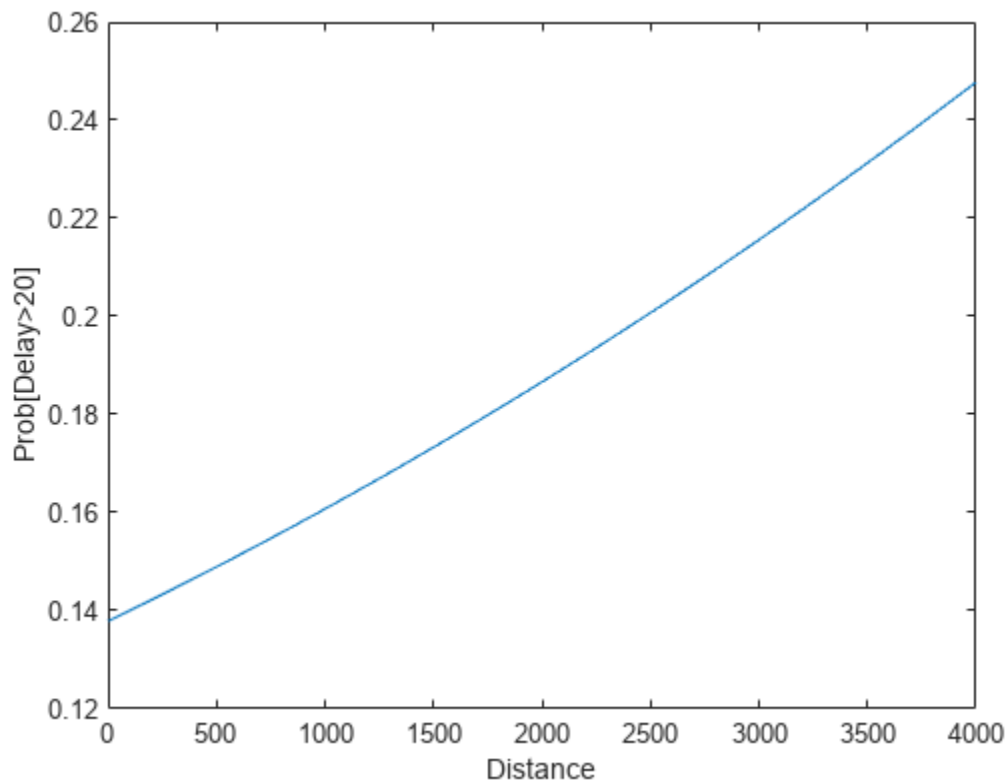

Local Functions

Listed here are the map and reduce functions that mapreduce applies to the data.

```
function logitMapper(b,t,~,intermKVStore)
% Get data input table and remove any rows with missing values
y = t.ArrDelay;
x = t.Distance;
t = ~isnan(x) & ~isnan(y);
y = y(t)>20;           % late by more than 20 min
x = x(t)/1000;        % distance in thousands of miles

% Compute the linear combination of the predictors, and the estimated mean
% probabilities, based on the coefficients from the previous iteration
if ~isempty(b)
% Compute xb as the linear combination using the current coefficient
% values, and derive mean probabilities mu from them
xb = b(1)+b(2)*x;
mu = 1./(1+exp(-xb));
else
% This is the first iteration. Compute starting values for mu that are
% 1/4 if y=0 and 3/4 if y=1. Derive xb values from them.
mu = (y+.5)/2;
xb = log(mu./(1-mu));
end

% To perform weighted least squares, compute a sum of squares and cross
% products matrix:
%      (X'*W*X) = (X1'*W1*X1) + (X2'*W2*X2) + ... + (Xn'*Wn*Xn),
% where X = [X1;X2;...;Xn] and W = [W1;W2;...;Wn].
%
% The mapper receives one chunk at a time and computes one of the terms on
% the right hand side. The reducer adds all of the terms to get the
% quantity on the left hand side, and then performs the regression.
w = (mu.*(1-mu));           % weights
z = xb + (y - mu) .* 1./w;  % adjusted response

X = [ones(size(x)),x,z];    % matrix of unweighted data
wss = X' * bsxfun(@times,w,X); % weighted cross-products X1'*W1*X1

% Store the results for this part of the data.
add(intertermKVStore, 'key', wss);
end
%-----
function logitReducer(~,intermValIter,outKVStore)
% We will operate over chunks of the data, updating the count, mean, and
% covariance each time we add a new chunk
old = 0;

% We want to perform weighted least squares. We do this by computing a sum
% of squares and cross products matrix
%      M = (X'*W*X) = (X1'*W1*X1) + (X2'*W2*X2) + ... + (Xn'*Wn*Xn)
% where X = [X1;X2;...;Xn] and W = [W1;W2;...;Wn].
%
% The mapper has computed the terms on the right hand side. Here in the
% reducer we just add them up.

while hasNext(intertermValIter)
```

```
    new = getNext(intermValIter);
    old = old+new;
end
M = old; % the value on the left hand side

% Compute coefficients estimates from M. M is a matrix of sums of squares
% and cross products for [X Y] where X is the design matrix including a
% constant term and Y is the adjusted response for this iteration. In other
% words, Y has been included as an additional column of X. First we
% separate them by extracting the X'*W*X part and the X'*W*Y part.
XtWX = M(1:end-1,1:end-1);
XtWY = M(1:end-1,end);

% Solve the normal equations.
b = XtWX\XtWY;

% Return the vector of coefficient estimates.
add(outKVStore, 'key', b);
end
%-----
```

See Also

mapreduce | tabularTextDatastore

More About

- “Getting Started with MapReduce” on page 13-3
- “Build Effective Algorithms with MapReduce” on page 13-18

Tall Skinny QR (TSQR) Matrix Factorization Using MapReduce

This example shows how to compute a tall skinny QR (TSQR) factorization using `mapreduce`. It demonstrates how to chain `mapreduce` calls to perform multiple iterations of factorizations, and uses the `info` argument of the `map` function to compute numeric keys.

Prepare Data

Create a datastore using the `airlinesmall.csv` data set. This 12-megabyte data set contains 29 columns of flight information for several airline carriers, including arrival and departure times. In this example, the variables of interest are `ArrDelay` (flight arrival delay), `DepDelay` (flight departure delay) and `Distance` (total flight distance).

```
ds = tabularTextDatastore('airlinesmall.csv', 'TreatAsMissing', 'NA');
ds.ReadSize = 1000;
ds.SelectedVariableNames = {'ArrDelay', 'DepDelay', 'Distance'};
```

The datastore treats 'NA' values as missing and replaces the missing values with NaN values by default. The `ReadSize` property lets you specify how to partition the data into blocks. Additionally, the `SelectedVariableNames` property allows you to work with only the specified variables of interest, which you can verify using `preview`.

```
preview(ds)
```

```
ans=8x3 table
   ArrDelay   DepDelay   Distance
   _____   _____   _____
         8         12         308
         8          1         296
        21         20         480
        13         12         296
         4          -1         373
        59         63         308
         3          -2         447
        11          -1         954
```

Chain MapReduce Calls

The implementation of the multi-iteration TSQR algorithm needs to chain consecutive `mapreduce` calls. To demonstrate the general chaining design pattern, this example uses two `mapreduce` iterations. The output from the `map` function calls is passed into a large set of reducers, and then the output of these reducers becomes the input for the next `mapreduce` iteration.

First MapReduce Iteration

In the first iteration, the `map` function, `tsqrMapper`, receives one block (the i th) of data, which is a table of size $N_i \times 3$. The mapper computes the R matrix of this block of data and stores it as an intermediate result. Then, `mapreduce` aggregates the intermediate results by unique key before sending them to the `reduce` function. Thus, `mapreduce` sends all intermediate R matrices with the same key to the same reducer.

Since the reducer uses `qr`, which is an in-memory MATLAB® function, it's best to first make sure that the R matrices fit in memory. This example divides the dataset into eight partitions. The `mapreduce`

function reads the data in blocks and passes the data along with some meta information to the map function. The `info` input argument is the second input to the map function and it contains the read offset and file size information that are necessary to generate the key,

```
key = ceil(offset/fileSize/numPartitions).
```

Display the map function file.

```
function tsqrMapper(data, info, intermKVStore)
    x = data{:, :};
    x(any(isnan(x),2), :) = []; % Remove missing values
    [~, r] = qr(x,0);

    % intermKey = randi(4); % random integer key for partitioning intermediate results
    intermKey = computeKey(info, 8);
    add(intermKVStore, intermKey, r);

    function key = computeKey(info, numPartitions)
        fileSize = info.FileSize; % total size of the underlying data file
        partitionSize = fileSize/numPartitions; % size in bytes of each partition
        offset = info.Offset; % offset in bytes of the current read
        key = ceil(offset/partitionSize);
    end
end
```

The reduce function receives a list of the intermediate R matrices, vertically concatenates them, and computes the R matrix of the concatenated matrix.

Display the reduce function file.

```
function tsqrReducer(intermKey, intermValIter, outKVStore)
    x = [];

    while (intermValIter.hasNext)
        x = [x; intermValIter.getNext];
    end
    % Note that this approach assumes the concatenated intermediate values fit
    % in memory. Consider increasing the number of reduce tasks (increasing the
    % number of partitions in the tsqrMapper) and adding more iterations if it
    % does not fit in memory.

    [~, r] = qr(x,0);

    add(outKVStore, intermKey, r);
end
```

Use `mapreduce` to apply the map and reduce functions to the datastore, `ds`.

```
outds1 = mapreduce(ds, @tsqrMapper, @tsqrReducer);
```

```
*****
*           MAPREDUCE PROGRESS           *
*****
Map   0% Reduce  0%
Map  10% Reduce  0%
Map  20% Reduce  0%
Map  30% Reduce  0%
Map  40% Reduce  0%
```



```

Map 50% Reduce 0%
Map 60% Reduce 0%
Map 70% Reduce 0%
Map 80% Reduce 0%
Map 90% Reduce 0%
Map 100% Reduce 0%
Map 100% Reduce 11%
Map 100% Reduce 22%
Map 100% Reduce 33%
Map 100% Reduce 44%
Map 100% Reduce 56%
Map 100% Reduce 67%
Map 100% Reduce 78%
Map 100% Reduce 89%
Map 100% Reduce 100%

```

mapreduce returns an output datastore, `outds1`, with files in the current folder.

Second MapReduce Iteration

The second iteration uses the output of the first iteration, `outds1`, as its input. This iteration uses an identity mapper, `identityMapper`, which simply copies over the data using a single key, 'Identity'.

Display the identity mapper file.

```

function identityMapper(data, info, intermKVStore)
    % This mapper function simply copies the data and add them to the
    % intermKVStore as intermediate values.
    x = data.Value{:, :};
    add(intermKVStore, 'Identity', x);
end

```

The reducer function is the same in both iterations. The use of a single key by the map function means that `mapreduce` only calls the reduce function once in the second iteration.

Use `mapreduce` to apply the identity mapper and the same reducer to the output from the first `mapreduce` call.

```
outds2 = mapreduce(outds1, @identityMapper, @tsqrReducer);
```

```

*****
*          MAPREDUCE PROGRESS          *
*****
Map 0% Reduce 0%
Map 11% Reduce 0%
Map 22% Reduce 0%
Map 33% Reduce 0%
Map 44% Reduce 0%
Map 55% Reduce 0%
Map 66% Reduce 0%
Map 77% Reduce 0%
Map 88% Reduce 0%
Map 100% Reduce 0%
Map 100% Reduce 100%

```

View Results

Read the final results from the output datastore.

```

r = readall(outds2);
r.Value{:}

ans = 3×3
105 ×

    0.1091    0.0893    0.5564
         0   -0.0478   -0.4890
         0         0    3.0130

```

Local Functions

Listed here are the map and reduce functions that mapreduce applies to the data.

```

function tsqrMapper(data, info, intermKVStore)
    x = data{:,:};
    x(any(isnan(x),2),:) = [];% Remove missing values
    [~, r] = qr(x,0);

    % intermKey = randi(4); % random integer key for partitioning intermediate results
    intermKey = computeKey(info, 8);
    add(intermKVStore,intermKey, r);

    function key = computeKey(info, numPartitions)
        fileSize = info.FileSize; % total size of the underlying data file
        partitionSize = fileSize/numPartitions; % size in bytes of each partition
        offset = info.Offset; % offset in bytes of the current read
        key = ceil(offset/partitionSize);
    end
end
%-----
function tsqrReducer(intermKey, intermValIter, outKVStore)
    x = [];

    while (intermValIter.hasNext)
        x = [x;intermValIter.getnext];
    end
    % Note that this approach assumes the concatenated intermediate values fit
    % in memory. Consider increasing the number of reduce tasks (increasing the
    % number of partitions in the tsqrMapper) and adding more iterations if it
    % does not fit in memory.

    [~, r] =qr(x,0);

    add(outKVStore,intermKey,r);
end
%-----
function identityMapper(data, info, intermKVStore)
    % This mapper function simply copies the data and add them to the
    % intermKVStore as intermediate values.
    x = data.Value{:,:};
    add(intermKVStore,'Identity', x);
end
%-----

```

Reference

- 1 Paul G. Constantine and David F. Gleich. 2011. Tall and skinny QR factorizations in MapReduce architectures. In Proceedings of the Second International Workshop on MapReduce and Its Applications (MapReduce '11). ACM, New York, NY, USA, 43-50. DOI=10.1145/1996092.1996103 <https://doi.acm.org/10.1145/1996092.1996103>

See Also

mapreduce | tabularTextDatastore

More About

- “Getting Started with MapReduce” on page 13-3
- “Build Effective Algorithms with MapReduce” on page 13-18

Compute Maximum Average HSV of Images with MapReduce

This example shows how to use `ImageDatastore` and `mapreduce` to find images with maximum hue, saturation and brightness values in an image collection.

Prepare Data

Create a datastore using the images in `toolbox/matlab/demos` and `toolbox/matlab/imagesci`. The selected images have the extensions `.jpg`, `.tif` and `.png`.

```
demoFolder = fullfile(matlabroot, 'toolbox', 'matlab', 'demos');
imsciFolder = fullfile(matlabroot, 'toolbox', 'matlab', 'imagesci');
```

Create a datastore using the folder paths, and filter which images are included in the datastore using the `FileExtensions` Name-Value pair.

```
ds = imageDatastore({demoFolder, imsciFolder}, ...
    'FileExtensions', {'jpg', 'tif', 'png'});
```

Find Average Maximum HSV from All Images

One way to find the maximum average hue, saturation, and brightness values in the collection of images is to use `readimage` within a for-loop, processing the images one at a time. For an example of this method, see “Read and Analyze Image Files” on page 13-100.

This example uses `mapreduce` to accomplish the same task, however, the `mapreduce` method is highly scalable to larger collections of images. While the for-loop method is reasonable for small collections of images, it does not scale well to a large collection of images.

Scale to MapReduce

- The `mapreduce` function requires a map function and a reduce function as inputs.
- The map function receives blocks of data and outputs intermediate results.
- The reduce function reads the intermediate results and produces a final result.

Map Function

- In this example, the map function stores the image data and the average HSV values as intermediate values.
- The intermediate values are associated with 3 keys, 'Average Hue', 'Average Saturation' and 'Average Brightness'.

```
function hueSaturationValueMapper(data, info, intermKVStore)
    if ~ismatrix(data)
        hsv = rgb2hsv(data);

        % Extract Hue values
        h = hsv(:,:,1);

        % Extract Saturation values
        s = hsv(:,:,2);

        % Extract Brightness values
        v = hsv(:,:,3);
```

```

% Find average of HSV values
avgH = mean(h(:));
avgS = mean(s(:));
avgV = mean(v(:));

% Add intermediate key-value pairs
add(intermKVStore, 'Average Hue', struct('Filename', info.Filename, 'Avg', avgH));
add(intermKVStore, 'Average Saturation', struct('Filename', info.Filename, 'Avg', avgS));
add(intermKVStore, 'Average Brightness', struct('Filename', info.Filename, 'Avg', avgV));
end
end

```

Reduce Function

- The reduce function receives a list of the image file names along with the respective average HSV values and finds the overall maximum values of average hue, saturation and brightness values.
- `mapreduce` only calls this reduce function 3 times, since the map function only adds three unique keys.
- The reduce function uses `add` to add a final key-value pair to the output. For example, 'Maximum Average Hue' is the key and the respective file name is the value.

```

function hueSaturationValueReducer(key, intermValIter, outKVStore)
    maxAvg = 0;
    maxImageFilename = '';

    % Loop over values for each key
    while hasNext(intermValIter)
        value = getNext(intermValIter);
        % Compare values to determine maximum
        if value.Avg > maxAvg
            maxAvg = value.Avg;
            maxImageFilename = value.Filename;
        end
    end

    % Add final key-value pair
    add(outKVStore, ['Maximum ' key], maxImageFilename);
end

```

Run MapReduce

Use `mapreduce` to apply the map and reduce functions to the datastore, `ds`.

```
maxHSV = mapreduce(ds, @hueSaturationValueMapper, @hueSaturationValueReducer);
```

```

*****
*      MAPREDUCE PROGRESS      *
*****
Map   0% Reduce   0%
Map  12% Reduce   0%
Map  25% Reduce   0%
Map  37% Reduce   0%
Map  50% Reduce   0%
Map  62% Reduce   0%
Map  75% Reduce   0%
Map  87% Reduce   0%

```

```
Map 100% Reduce 0%
Map 100% Reduce 33%
Map 100% Reduce 67%
Map 100% Reduce 100%
```

`mapreduce` returns a datastore, `maxHSV`, with files in the current folder.

Read and display the final result from the output datastore, `maxHSV`. Use `find` and `strcmp` to find the file index from the `Files` property.

```
tbl = readall(maxHSV);
for i = 1:height(tbl)
    figure;
    idx = find(strcmp(ds.Files, tbl.Value{i}));
    imshow(readimage(ds, idx), 'InitialMagnification', 'fit');
    title(tbl.Key{i});
end
```

Maximum Average Hue



Maximum Average Saturation

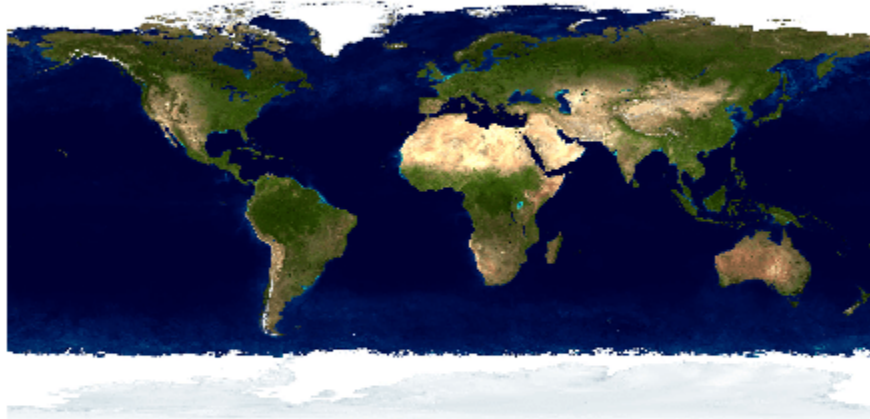

Maximum Average Brightness



Local Functions

Listed here are the map and reduce functions that mapreduce applies to the data.

```
function hueSaturationValueMapper(data, info, intermKVStore)
    if ~ismatrix(data)
        hsv = rgb2hsv(data);

        % Extract Hue values
        h = hsv(:,:,1);

        % Extract Saturation values
        s = hsv(:,:,2);

        % Extract Brightness values
        v = hsv(:,:,3);

        % Find average of HSV values
        avgH = mean(h(:));
        avgS = mean(s(:));
        avgV = mean(v(:));

        % Add intermediate key-value pairs
        add(intermKVStore, 'Average Hue', struct('Filename', info.Filename, 'Avg', avgH));
        add(intermKVStore, 'Average Saturation', struct('Filename', info.Filename, 'Avg', avgS));
        add(intermKVStore, 'Average Brightness', struct('Filename', info.Filename, 'Avg', avgV));
    end
end
```



```
%-----  
function hueSaturationValueReducer(key, intermValIter, outKVSTore)  
    maxAvg = 0;  
    maxImageFilename = '';  
  
    % Loop over values for each key  
    while hasNext(intermValIter)  
        value = getNext(intermValIter);  
        % Compare values to determine maximum  
        if value.Avg > maxAvg  
            maxAvg = value.Avg;  
            maxImageFilename = value.Filename;  
        end  
    end  
  
    % Add final key-value pair  
    add(outKVSTore, ['Maximum ' key], maxImageFilename);  
end  
%-----
```

See Also

mapreduce | imageDatastore | tall

More About

- “Getting Started with MapReduce” on page 13-3
- “Build Effective Algorithms with MapReduce” on page 13-18
- “Tall Arrays for Out-of-Memory Data” on page 13-146
- “Getting Started with Datastore” on page 13-86

Getting Started with Datastore

In this section...

- “What Is a Datastore?” on page 13-86
- “Create and Read from a Datastore” on page 13-87

What Is a Datastore?

A datastore is an object for reading a single file or a collection of files or data. The datastore acts as a repository for data that has the same structure and formatting. For example, each file in a datastore must contain data of the same type (such as numeric or text) appearing in the same order, and separated by the same delimiter.

Year	Month	DayofMor	DayOfWei	DepTime	CRSDepTii	ArrTime	CRSArrTir	UniqueCa	FlightNun	TailNum	ActualElaj	CRSElapse	AirTime	ArrDelay	DepDelay	Origin	Dest	Distanc
2000	3	2	4	1641	1635	1831	1830	WN	1726	N353	50	55	41	1	6	ELP	LBB	
2000	3	5	7	2004	1950	2307	2249	AA	1174	N410AA	123	119	98	18	14	RNA	LGA	
2000	3	10	11	7	1042	1042	1107	PI	929	NA	25	25	NA	0	0	SYR	ITH	
1990	10	21	3	642	630	735	727	PS	1503	NA	53	57	NA	8	12	LAX	SJC	
1990	10	26	1	1021	1020	1124	1116	PS	1550	NA	63	56	NA	8	1	SJC	BUR	
1990	10	23	5	2055	2035	2218	2157	PS	1589	NA	83	82	NA	21	20	SAN	SMF	
1990	10	23	5	1332	1320	1431	1418	PS	1655	NA	59	58	NA	13	12	BUR	SJC	
1990	10	22	4	629	630	746	742	PS	1702	NA	77	72	NA	4	-1	SMF	LAX	
1990	10	28	3	1446	1343	1547	1448	PS	1729	NA	61	65	NA	59	63	LAX	SJC	
1990	10	8	4	928	930	1052	1049	PS	1763	NA	84	79	NA	3	-2	SAN	SFO	
1990	10	10	6	859	900	1134	1123	PS	1800	NA	155	143	NA	11	-1	SEA	LAX	
1990	10	20	2	1833	1830	1929	1926	PS	1831	NA	56	56	NA	3	3	LAX	SJC	
1990	10	15	4	1041	1040	1157	1155	PS	1864	NA	76	75	NA	2	1	SFO	LAS	
1990	10	15	4	1608	1553	1656	1640	PS	1907	NA	48	47	NA	16	15	LAX	FAT	
1990	10	21	3	949	940	1055	1052	PS	1939	NA	66	72	NA	3	9	LGB	SFO	
1990	10	22	4	1902	1847	2030	1951	PS	1973	NA	88	64	NA	39	15	LAX	OAK	
1990	10	16	5	1910	1838	2052	1955	TW	19	NA	162	137	NA	57	32	STL	DEN	
1990	10	2	5	1130	1133	1237	1237	TW	59	NA	187	184	NA	0	-3	STL	PHX	
1990	10	30	5	1400	1400	1920	1934	TW	102	NA	200	214	NA	-14	0	SNA	STL	
1990	10	28	3	841	830	1233	1218	TW	136	NA	172	168	NA	15	11	TUS	STL	
1990	10	5	1	1500	1445	1703	1655	TW	183	NA	243	250	NA	8	15	STL	SFO	
1990	10	27	2	1647	1640	1914	1903	TW	220	NA	87	83	NA	11	7	STL	DTW	
1990	10	15	4	1709	1710	1752	1749	TW	251	NA	103	99	NA	3	-1	PIT	STL	
1990	10	24	6	1515	1515	1544	1545	TW	283	NA	29	30	NA	-1	0	SRQ	RSW	
1990	10	25	7	2017	2017	2347	2329	TW	318	NA	150	132	NA	18	0	STL	BDL	
1990	10	25	7	2218	2220	2335	2322	TW						13	-2	STL	PHX	

A datastore is useful when:

- Each file in the collection might be too large to fit in memory. A datastore allows you to read and analyze data from each file in smaller portions that do fit in memory.
- Files in the collection have arbitrary names. A datastore acts as a repository for files in one or more folders. The files are not required to have sequential names.

You can create a datastore based on the type of data or application. The different types of datastores contain properties pertinent to the type of data that they support. For example, see the following table for a list of MATLAB datastores. For a complete list of datastores, see “Select Datastore for File Format or Application” on page 13-90.

Type of File or Data	Datastore Type
Text files containing column-oriented data, including CSV files.	TabularTextDatastore

Type of File or Data	Datastore Type
Image files, including formats that are supported by <code>imread</code> such as JPEG and PNG.	<code>ImageDatastore</code>
Spreadsheet files with a supported Excel format such as <code>.xlsx</code> .	<code>SpreadsheetDatastore</code>
Key-value pair data that are inputs to or outputs of <code>mapreduce</code> .	<code>KeyValueDatastore</code>
Parquet files containing column-oriented data.	<code>ParquetDatastore</code>
Custom file formats. Requires a provided function for reading data.	<code>FileDatastore</code>
Datastore for checkpointing tall arrays.	<code>TallDatastore</code>

Create and Read from a Datastore

Use the `tabularTextDatastore` function to create a datastore from the sample file `airlinesmall.csv`, which contains departure and arrival information about individual airline flights. The result is a `TabularTextDatastore` object.

```
ds = tabularTextDatastore('airlinesmall.csv')
```

```
ds =
```

```
TabularTextDatastore with properties:
```

```

    Files: {
        ...\matlab\toolbox\matlab\demos\airlinesmall.csv'
    }
    Folders: {
        ...\matlab\toolbox\matlab\demos'
    }
    FileEncoding: 'UTF-8'
    AlternateFileSystemRoots: {}
    PreserveVariableNames: false
    ReadVariableNames: true
    VariableNames: {'Year', 'Month', 'DayofMonth' ... and 26 more}
    DatetimeLocale: en_US

Text Format Properties:
    NumHeaderLines: 0
    Delimiter: ','
    RowDelimiter: '\r\n'
    TreatAsMissing: ''
    MissingValue: NaN

Advanced Text Format Properties:
    TextscanFormats: {'%f', '%f', '%f' ... and 26 more}
    TextType: 'char'
    ExponentCharacters: 'eEdD'
    CommentStyle: ''
    Whitespace: '\b\t'
    MultipleDelimitersAsOne: false

Properties that control the table returned by preview, read, readall:
    SelectedVariableNames: {'Year', 'Month', 'DayofMonth' ... and 26 more}
    SelectedFormats: {'%f', '%f', '%f' ... and 26 more}
    ReadSize: 20000 rows
    OutputType: 'table'
    RowTimes: []

Write-specific Properties:
    SupportedOutputFormats: ["txt" "csv" "xlsx" "xls" "parquet" "parq"]
    DefaultOutputFormat: "txt"

```

After creating the datastore, you can preview the data without having to load it all into memory. You can specify variables (columns) of interest using the `SelectedVariableNames` property to preview or read only those variables.

	A	B	C	D	E	F	G	H	I	J	K	L	M	N	O	P	Q	R	S
1	Year	Month	DayofMor	DayOfWe	DepTime	CRSDepTi	ArrTime	CRSArrTin	UniqueCa	FlightNun	TailNum	ActualElaj	CRSElapse	AirTime	ArrDelay	DepDelay	Origin	Dest	Dis
2	1987	10	21	3	642	630	735	727	PS	1503	NA	53	57	NA	8	12	LAX	SJC	
3	1987	10	26	1	1021	1020	1124	1116	PS	1550	NA	63	56	NA	8	1	SJC	BUR	
4	1987	10	23	5	2055	2035	2218	2157	PS	1589	NA	83	82	NA	21	20	SAN	SMF	
5	1987	10	23	5	1332	1320	1431	1418	PS	1655	NA	59	58	NA	13	12	BUR	SJC	
6	1987	10	22	4	629	630	746	742	PS	1702	NA	77	72	NA	4	-1	SMF	LAX	
7	1987	10	28	3	1446	1343	1547	1448	PS	1729	NA	61	65	NA	59	63	LAX	SJC	
8	1987	10	8	4	928	930	1052	1049	PS	1763	NA	84	79	NA	3	-2	SAN	SFO	
9	1987	10	10	6	859	900	1134	1123	PS	1800	NA	155	143	NA	11	-1	SEA	LAX	
10	1987	10	20	2	1833	1830	1929	1926	PS	1831	NA	56	56	NA	3	3	LAX	SJC	
11	1987	10	15	4	1041	1040	1157	1155	PS	1864	NA	76	75	NA	2	1	SFO	LAS	
12	1987	10	15	4	1608	1553	1656	1640	PS	1907	NA	48	47	NA	16	15	LAX	FAT	
13	1987	10	21	3	949	940	1055	1052	PS	1939	NA	66	72	NA	3	9	LGB	SFO	
14	1987	10	22	4	1902	1847	2030	1951	PS	1973	NA	88	64	NA	39	15	LAX	OAK	
15	1987	10	16	5	1910	1838	2052	1955	TW	19	NA	162	137	NA	57	32	STL	DEN	
16	1987	10	2	5	1130	1133	1237	1237	TW	59	NA	187	184	NA	0	-3	STL	PHX	
17	1987	10	30	5	1400	1400	1920	1934	TW	102	NA	200	214	NA	-14	0	SNA	STL	
18	1987	10	28	3	841	830	1233	1218	TW	136	NA	172	168	NA	15	11	TUS	STL	
19	1987	10	5	1	1500	1445	1703	1655	TW	183	NA	243	250	NA	8	15	STL	SFO	
20	1987	10	27	2	1647	1640	1914	1903	TW	220	NA	87	83	NA	11	7	STL	DTW	
					1708	1710	1752	1749	TW						3	-1	PIT	STL	

```
ds.SelectedVariableNames = {'DepTime', 'DepDelay'};
preview(ds)
```

```
ans =
```

```
8x2 table
```

DepTime	DepDelay
642	12
1021	1
2055	20
1332	12
629	-1
1446	63
928	-2
859	-1

You can specify the values in your data which represent missing values. In `airlinesmall.csv`, missing values are represented by `NA`.

```
ds.TreatAsMissing = 'NA';
```

If all of the data in the datastore for the variables of interest fit in memory, you can read it using the `readall` function.

```
T = readall(ds);
```

Otherwise, read the data in smaller subsets that do fit in memory, using the `read` function. By default, the `read` function reads from a `TabularTextDatastore` 20,000 rows at a time. However, you can change this value by assigning a new value to the `ReadSize` property.

```
ds.ReadSize = 15000;
```

Reset the datastore to the initial state before re-reading, using the `reset` function. By calling the `read` function within a `while` loop, you can perform intermediate calculations on each subset of data, and then aggregate the intermediate results at the end. This code calculates the maximum value of the `DepDelay` variable.

```
reset(ds)
X = [];
while hasdata(ds)
    T = read(ds);
    X(end+1) = max(T.DepDelay);
end
maxDelay = max(X)

maxDelay =

    1438
```

If the data in each individual file fits in memory, you can specify that each call to `read` should read one complete file rather than a specific number of rows.

```
reset(ds)
ds.ReadSize = 'file';
X = [];
while hasdata(ds)
    T = read(ds);
    X(end+1) = max(T.DepDelay);
end
maxDelay = max(X);
```

In addition to reading subsets of data in a datastore, you can apply map and reduce functions to the datastore using `mapreduce` or create a tall array using `tall`. For more information, see “Getting Started with MapReduce” on page 13-3 and “Tall Arrays for Out-of-Memory Data” on page 13-146.

See Also

`tabularTextDatastore` | `imageDatastore` | `spreadsheetDatastore` | `KeyValueDatastore` | `fileDatastore` | `tall` | `mapreduce`

Related Examples

- “Select Datastore for File Format or Application” on page 13-90
- “Read and Analyze Large Tabular Text File” on page 13-98
- “Read and Analyze Image Files” on page 13-100

Select Datastore for File Format or Application

A datastore is a repository for collections of data that are too large to fit in memory. Each file format and application uses a different type of datastore, which contains properties pertinent to the type of data or application that it supports. MATLAB provides datastores for standard file formats such as Excel files and datastores for specific applications such as Deep Learning. In addition to the existing datastores, if your data is in a proprietary format, then you can develop a customized datastore using the custom datastore framework.

Datastores for Standard File Formats

For a collection of data in standard file format use one of these options.

Datastore	Description
TabularTextDatastore	Text files containing column-oriented data, including CSV files
SpreadsheetDatastore	Spreadsheet files with a supported Excel format such as .xlsx
ImageDatastore	Image files, including formats that are supported by <code>imread</code> such as JPEG and PNG
ParquetDatastore	Parquet files containing column-oriented data
FileDatastore	Files with nonstandard file format Requires a custom file reading function

Transform or combine existing datastores.

Datastore	Description
CombinedDatastore	Datastore to combine data read from multiple underlying datastores
SequentialDatastore	Sequentially read data from multiple underlying datastores
TransformedDatastore	Datastore to transform underlying datastore

Datastores to integrate with MapReduce and tall arrays.

Datastore	Description
KeyValueDatastore	Key-value pair data that are inputs to or outputs of <code>mapreduce</code>
TallDatastore	Datastore for checkpointing tall arrays

Datastores for Specific Applications

Based on your application use one of these datastores.

Application	Datastore	Description	Toolbox Required
Simulink Model Data	SimulationDatastore	Datastore for simulation input and output data that you use with a Simulink model	Simulink
Simulation Ensemble and Predictive Maintenance Data	simulationEnsembleDatastore	Datastore to manage simulation ensemble data	Predictive Maintenance Toolbox™
	fileEnsembleDatastore	Datastore to manage ensemble data in custom file format	Predictive Maintenance Toolbox
Measurement Data Format (MDF) Files	mdfDatastore	Datastore for collection of MDF files	Vehicle Network Toolbox™
	mdfDatastore	Datastore for collection of MDF files	Powertrain Blockset™
Deep Learning Datastores for preprocessing image or sequence data	pixelLabelDatastore	Datastore for pixel label data	Computer Vision Toolbox™ and Deep Learning Toolbox™
	pixelLabelImageDatastore	Datastore for training semantic segmentation networks Datastore is nondeterministic	Computer Vision Toolbox and Deep Learning Toolbox
	boxLabelDatastore	Datastore for bounding box label data	Computer Vision Toolbox and Deep Learning Toolbox
	signalDatastore	Datastore for collection of signal files	Signal Processing Toolbox™ and Deep Learning Toolbox
	randomPatchExtractionDatastore	Datastore for extracting random patches from images or pixel label images Datastore is nondeterministic	Image Processing Toolbox™ and Deep Learning Toolbox
	denoisingImageDatastore	Datastore to train an image denoising deep neural network Datastore is nondeterministic	Image Processing Toolbox and Deep Learning Toolbox

Application	Datastore	Description	Toolbox Required
	<code>augmentedImageDatastore</code>	Datastore for resizing and augmenting training images Datastore is nondeterministic	Deep Learning Toolbox
Audio Data	<code>audioDatastore</code>	Datastore for collection of audio files	Audio Toolbox™
Out-of-Memory Image Data	<code>blockedImageDatastore</code>	Datastore to manage blocks of a single image that is too large to fit in memory	Image Processing Toolbox
Database Data	<code>databaseDatastore</code>	Datastore for collections of data in a relational database	Database Toolbox

Custom File Formats

For a collection of data in a custom file format, if each individual file fits in memory, use `FileDatastore` along with your custom file reading function. Otherwise, develop your own fully customized datastore for custom or proprietary data using the `matlab.io.Datastore` class. See “Develop Custom Datastore” on page 13-109.

Nondeterministic Datastores

Datastores that do not return the exact same data for a call to the `read` function after a call to the `reset` function are nondeterministic datastores. Do not use nondeterministic datastores with `tall` arrays, `mapreduce`, or any other code that requires reading the data more than once.

Some applications require data that is randomly augmented or transformed. For example, the `augmentedImageDatastore` datastore, from the deep learning application augments training image data with randomized preprocessing operations to help prevent the network from overfitting and memorizing the exact details of the training images. The output of this datastore is different every time you perform a `read` operation after a call to `reset`.

See Also

`TabularTextDatastore` | `SpreadsheetDatastore` | `ImageDatastore` | `FileDatastore` | `TallDatastore` | `tall`

More About

- “Getting Started with Datastore” on page 13-86
- “Tall Arrays for Out-of-Memory Data” on page 13-146
- “Develop Custom Datastore” on page 13-109

Work with Remote Data

You can read and write data from a remote location using MATLAB functions and objects, such as file I/O functions and some datastore objects. These examples show how to set up, read from, and write to remote locations on the following cloud storage platforms:

- Amazon S3 (Simple Storage Service)
- Azure Blob Storage (previously known as Windows Azure Storage Blob (WASB))
- Hadoop Distributed File System (HDFS)

Amazon S3

MATLAB lets you use Amazon S3 as an online file storage web service offered by Amazon Web Services. When you specify the location of the data, you must specify the full path to the files or folders using a uniform resource locator (URL) of the form

```
s3://bucketname/path_to_file
```

bucketname is the name of the container and *path_to_file* is the path to the file or folders.

Amazon S3 provides data storage through web services interfaces. You can use a *bucket* as a container to store objects in Amazon S3.

Set Up Access

To work with remote data in Amazon S3, you must set up access first:

- 1 Sign up for an Amazon Web Services (AWS) root account. See [Amazon Web Services: Account](#).
- 2 Using your AWS root account, create an IAM (Identity and Access Management) user. See [Creating an IAM User in Your AWS Account](#).
- 3 Generate an access key to receive an access key ID and a secret access key. See [Managing Access Keys for IAM Users](#).
- 4 Configure your machine with the AWS access key ID, secret access key, and region using the AWS Command Line Interface tool from <https://aws.amazon.com/cli/>. Alternatively, set the environment variables directly by using `setenv`:
 - `AWS_ACCESS_KEY_ID` and `AWS_SECRET_ACCESS_KEY` — Authenticate and enable use of Amazon S3 services. (You generated this pair of access key variables in step 3.)
 - `AWS_DEFAULT_REGION` (optional) — Select the geographic region of your bucket. The value of this environment variable is typically determined automatically, but the bucket owner might require that you set it manually.
 - `AWS_SESSION_TOKEN` (optional) — Specify the session token if you are using temporary security credentials, such as with AWS® Federated Authentication.

If you are using Parallel Computing Toolbox, you must ensure the cluster has been configured to access S3 services. You can copy your client environment variables to the workers on a cluster by setting `EnvironmentVariables` in `parpool`, `batch`, `createJob`, or in the Cluster Profile Manager.

Read Data from Amazon S3

The following example shows how to use an `ImageDatastore` object to read a specified image from Amazon S3, and then display the image to screen.

```

setenv('AWS_ACCESS_KEY_ID', 'YOUR_AWS_ACCESS_KEY_ID');
setenv('AWS_SECRET_ACCESS_KEY', 'YOUR_AWS_SECRET_ACCESS_KEY');

ds = imageDatastore('s3://bucketname/image_datastore/jpegfiles', ...
    'IncludeSubfolders', true, 'LabelSource', 'foldernames');
img = ds.readimage(1);
imshow(img)

```

Write Data to Amazon S3

The following example shows how to use a `tabularTextDatastore` object to read tabular data from Amazon S3 into a tall array, preprocess it by removing missing entries and sorting, and then write it back to Amazon S3.

```

setenv('AWS_ACCESS_KEY_ID', 'YOUR_AWS_ACCESS_KEY_ID');
setenv('AWS_SECRET_ACCESS_KEY', 'YOUR_AWS_SECRET_ACCESS_KEY');

ds = tabularTextDatastore('s3://bucketname/dataset/airlinesmall.csv', ...
    'TreatAsMissing', 'NA', 'SelectedVariableNames', {'ArrDelay'});
tt = tall(ds);
tt = sortrows(rmmissing(tt));
write('s3://bucketname/preprocessedData/', tt);

```

To read your tall data back, use the `datastore` function.

```

ds = datastore('s3://bucketname/preprocessedData/');
tt = tall(ds);

```

Azure Blob Storage

MATLAB lets you use Azure Blob Storage for online file storage. When you specify the location of the data, you must specify the full path to the files or folders using a uniform resource locator (URL) of the form

```
wasbs://container@account/path_to_file/file.ext
```

`container@account` is the name of the container and `path_to_file` is the path to the file or folders.

Azure provides data storage through web services interfaces. You can use a *blob* to store data files in Azure. See [What is Azure](#) for more information.

Set Up Access

To work with remote data in Azure storage, you must set up access first:

- 1 Sign up for a Microsoft Azure account, see [Microsoft Azure Account](#).
- 2 Set up your authentication details by setting exactly one of the two following environment variables using `setenv`:
 - `MW_WASB_SAS_TOKEN` — Authentication via Shared Access Signature (SAS)

Obtain an SAS. For details, see the "Get the SAS for a blob container" section in [Manage Azure Blob Storage resources with Storage Explorer](#).

In MATLAB, set `MW_WASB_SAS_TOKEN` to the SAS query string. For example,

```
setenv MW_WASB_SAS_TOKEN '?st=2017-04-11T09%3A45%3A00Z&se=2017-05-12T09%3A45%3A00Z&sp=rl&sv=2015-12-11&sr=c&sig=
```

You must set this string to a valid SAS token generated from the Azure Storage web UI or Explorer.

- **MW_WASB_SECRET_KEY** — Authentication via one of the Account's two secret keys

Each Storage Account has two secret keys that permit administrative privilege access. This same access can be given to MATLAB without having to create an SAS token by setting the **MW_WASB_SECRET_KEY** environment variable. For example:

```
setenv MW_WASB_SECRET_KEY '1234567890ABCDEF1234567890ABCDEF1234567890ABCDEF'
```

If you are using Parallel Computing Toolbox, you must copy your client environment variables to the workers on a cluster by setting `EnvironmentVariables` in `parpool`, `batch`, `createJob`, or in the Cluster Profile Manager.

For more information, see [Use Azure storage with Azure HDInsight clusters](#).

Read Data from Azure

To read data from an Azure Blob Storage location, specify the location using the following syntax:

```
wasbs://container@account/path_to_file/file.ext
```

container@account is the name of the container and *path_to_file* is the path to the file or folders.

For example, if you have a file `airlinesmall.csv` in a folder `/airline` on a test storage account `wasbs://blobContainer@storageAccount.blob.core.windows.net/`, then you can create a datastore by using:

```
location = 'wasbs://blobContainer@storageAccount.blob.core.windows.net/airline/airlinesmall.csv';
ds = tabularTextDatastore(location, 'TreatAsMissing', 'NA', ...
    'SelectedVariableNames', {'ArrDelay'});
```

You can use Azure for all calculations datastores support, including direct reading, `mapreduce`, tall arrays and deep learning. For example, create an `ImageDatastore` object, read a specified image from the datastore, and then display the image to screen.

```
setenv('MW_WASB_SAS_TOKEN', 'YOUR_WASB_SAS_TOKEN');
ds = imageDatastore('wasbs://YourContainer@YourAccount.blob.core.windows.net/', ...
    'IncludeSubfolders', true, 'LabelSource', 'foldernames');
img = ds.readimage(1);
imshow(img)
```

Write Data to Azure

This example shows how to read tabular data from Azure into a tall array using a `tabularTextDatastore` object, preprocess it by removing missing entries and sorting, and then write it back to Azure.

```
setenv('MW_WASB_SAS_TOKEN', 'YOUR_WASB_SAS_TOKEN');

ds = tabularTextDatastore('wasbs://YourContainer@YourAccount.blob.core.windows.net/dataset/airline', ...
    'TreatAsMissing', 'NA', 'SelectedVariableNames', {'ArrDelay'});
tt = tall(ds);
tt = sortrows(rmmissing(tt));
write('wasbs://YourContainer@YourAccount.blob.core.windows.net/preprocessedData/', tt);
```

To read your tall data back, use the `datastore` function.

```
ds = datastore('wasbs://YourContainer@YourAccount.blob.core.windows.net/preprocessedData/');
tt = tall(ds);
```

Hadoop Distributed File System

Specify Location of Data

MATLAB lets you use Hadoop Distributed File System (HDFS) as an online file storage web service. When you specify the location of the data, you must specify the full path to the files or folders using a uniform resource locator (URL) of one of these forms:

```
hdfs:/path_to_file
```

```
hdfs:///path_to_file
```

```
hdfs://hostname/path_to_file
```

hostname is the name of the host or server and *path_to_file* is the path to the file or folders. Specifying the *hostname* is optional. When you do not specify the *hostname*, Hadoop uses the default host name associated with the Hadoop Distributed File System (HDFS) installation in MATLAB.

For example, you can use either of these commands to create a datastore for the file, `file1.txt`, in a folder named `data` located at a host named `myserver`:

- `ds = tabularTextDatastore('hdfs:///data/file1.txt')`
- `ds = tabularTextDatastore('hdfs://myserver/data/file1.txt')`

If *hostname* is specified, it must correspond to the `namenode` defined by the `fs.default.name` property in the Hadoop XML configuration files for your Hadoop cluster.

Optionally, you can include the port number. For example, this location specifies a host named `myserver` with port `7867`, containing the file `file1.txt` in a folder named `data`:

```
'hdfs://myserver:7867/data/file1.txt'
```

The specified port number must match the port number set in your HDFS configuration.

Set Hadoop Environment Variable

Before reading from HDFS, use the `setenv` function to set the appropriate environment variable to the folder where Hadoop is installed. This folder must be accessible from the current machine.

- Hadoop v1 only — Set the `HADOOP_HOME` environment variable.
- Hadoop v2 only — Set the `HADOOP_PREFIX` environment variable.
- If you work with both Hadoop v1 and Hadoop v2, or if the `HADOOP_HOME` and `HADOOP_PREFIX` environment variables are not set, then set the `MATLAB_HADOOP_INSTALL` environment variable.

For example, use this command to set the `HADOOP_HOME` environment variable. *hadoop-folder* is the folder where Hadoop is installed, and */mypath/* is the path to that folder.

```
setenv('HADOOP_HOME', '/mypath/hadoop-folder');
```

HDFS data on Hortonworks or Cloudera

If your current machine has access to HDFS data on Hortonworks or Cloudera®, then you do not have to set the `HADOOP_HOME` or `HADOOP_PREFIX` environment variables. MATLAB automatically assigns these environment variables when using Hortonworks or Cloudera application edge nodes.

Prevent Clearing Code from Memory

When reading from HDFS or when reading Sequence files locally, the `datastore` function calls the `javaaddpath` command. This command does the following:

- Clears the definitions of all Java classes defined by files on the dynamic class path
- Removes all global variables and variables from the base workspace
- Removes all compiled scripts, functions, and MEX-functions from memory

To prevent persistent variables, code files, or MEX-files from being cleared, use the `mlock` function.

Write Data to HDFS

This example shows how to use a `tabularTextDatastore` object to write data to an HDFS location. Use the `write` function to write your tall and distributed arrays to a Hadoop Distributed File System. When you call this function on a distributed or tall array, you must specify the full path to a HDFS folder. The following example shows how to read tabular data from HDFS into a tall array, preprocess it by removing missing entries and sorting, and then write it back to HDFS.

```
ds = tabularTextDatastore('hdfs://myserver/some/path/dataset/airlinesmall.csv', ...
    'TreatAsMissing', 'NA', 'SelectedVariableNames', {'ArrDelay'});
tt = tall(ds);
tt = sortrows(rmmissing(tt));
write('hdfs://myserver/some/path/preprocessedData/', tt);
```

To read your tall data back, use the `datastore` function.

```
ds = datastore('hdfs://myserver/some/path/preprocessedData/');
tt = tall(ds);
```

See Also

[datastore](#) | [tabularTextDatastore](#) | [write](#) | [imageDatastore](#) | [imread](#) | [imshow](#) | [javaaddpath](#) | [mlock](#) | [setenv](#)

Related Examples

- “Read and Analyze Hadoop Sequence File” on page 13-107
- “Upload Deep Learning Data to the Cloud” (Deep Learning Toolbox)

Read and Analyze Large Tabular Text File

This example shows how to create a datastore for a large text file containing tabular data, and then read and process the data one block at a time or one file at a time.

Create a Datastore

Create a datastore from the sample file `airlinesmall.csv` using the `tabularTextDatastore` function. When you create the datastore, you can specify that the text, `NA`, in the data is treated as missing data.

```
ds = tabularTextDatastore('airlinesmall.csv', 'TreatAsMissing', 'NA');
```

You can modify the properties of the datastore by changing its properties. Modify the `MissingValue` property to specify that missing values are treated as 0.

```
ds.MissingValue = 0;
```

In this example, select the variable for the arrival delay, `ArrDelay`, as the variable of interest.

```
ds.SelectedVariableNames = 'ArrDelay';
```

Preview the data using the `preview` function. This function does not affect the state of the datastore.

```
data = preview(ds)
```

```
data=8x1 table
  ArrDelay
```

```
-----
      8
      8
     21
     13
      4
     59
      3
     11
```

Read Subsets of Data

By default, `read` reads from a `TabularTextDatastore` 20000 rows at a time. To read a different number of rows in each call to `read`, modify the `ReadSize` property of `ds`.

```
ds.ReadSize = 15000;
```

Read subsets of the data from `ds` using the `read` function in a `while` loop. The loop executes until `hasdata(ds)` returns `false`.

```
sums = [];
counts = [];
while hasdata(ds)
    T = read(ds);

    sums(end+1) = sum(T.ArrDelay);
```

```

    counts(end+1) = length(T.ArrDelay);
end

```

Compute the average arrival delay.

```

avgArrivalDelay = sum(sums)/sum(counts)
avgArrivalDelay = 6.9670

```

Reset the datastore to allow rereading of the data.

```

reset(ds)

```

Read One File at a Time

A datastore can contain multiple files, each with a different number of rows. You can read from the datastore one complete file at a time by setting the `ReadSize` property to `'file'`.

```

ds.ReadSize = 'file';

```

When you change the value of `ReadSize` from a number to `'file'` or vice versa, MATLAB® resets the datastore.

Read from `ds` using the `read` function in a `while` loop, as before, and compute the average arrival delay.

```

sums = [];
counts = [];
while hasdata(ds)
    T = read(ds);

    sums(end+1) = sum(T.ArrDelay);
    counts(end+1) = length(T.ArrDelay);
end
avgArrivalDelay = sum(sums)/sum(counts)
avgArrivalDelay = 6.9670

```

See Also

[tabularTextDatastore](#) | [tall](#) | [mapreduce](#)

Related Examples

- “Tall Arrays for Out-of-Memory Data” on page 13-146
- “Getting Started with MapReduce” on page 13-3

Read and Analyze Image Files

This example shows how to create a datastore for a collection of images, read the image files, and find the images with the maximum average hue, saturation, and brightness (HSV). For a similar example on image processing using the `mapreduce` function, see “Compute Maximum Average HSV of Images with MapReduce” on page 13-80.

Identify two MATLAB® directories and create a datastore containing images with `.jpg`, `.tif`, and `.png` extensions in those directories.

```
location1 = fullfile(matlabroot, 'toolbox', 'matlab', 'demos');
location2 = fullfile(matlabroot, 'toolbox', 'matlab', 'imagesci');

ds = imageDatastore({location1, location2}, 'FileExtensions', {'.jpg', '.tif', '.png'});
```

Initialize the maximum average HSV values and the corresponding image data.

```
maxAvgH = 0;
maxAvgS = 0;
maxAvgV = 0;
```

```
dataH = 0;
dataS = 0;
dataV = 0;
```

For each image in the collection, read the image file and calculate the average HSV values across all of the image pixels. If an average value is larger than that of a previous image, then record it as the new maximum (`maxAvgH`, `maxAvgS`, or `maxAvgV`) and record the corresponding image data (`dataH`, `dataS`, or `dataV`).

```
for i = 1:length(ds.Files)
    data = readimage(ds, i);           % Read the ith image
    if ~ismatrix(data)                 % Only process 3-dimensional color data
        hsv = rgb2hsv(data);          % Compute the HSV values from the RGB data

        h = hsv(:, :, 1);              % Extract the HSV values
        s = hsv(:, :, 2);
        v = hsv(:, :, 3);

        avgH = mean(h(:));             % Find the average HSV values across the image
        avgS = mean(s(:));
        avgV = mean(v(:));

        if avgH > maxAvgH              % Check for new maximum average hue
            maxAvgH = avgH;
            dataH = data;
        end

        if avgS > maxAvgS              % Check for new maximum average saturation
            maxAvgS = avgS;
            dataS = data;
        end

        if avgV > maxAvgV              % Check for new maximum average brightness
            maxAvgV = avgV;
            dataV = data;
        end
    end
end
```



```
end  
end  
end
```

View the images with the largest average hue, saturation, and brightness.

```
imshow(dataH, 'InitialMagnification', 'fit');  
title('Maximum Average Hue')
```



```
figure  
imshow(dataS, 'InitialMagnification', 'fit');  
title('Maximum Average Saturation');
```

Maximum Average Saturation

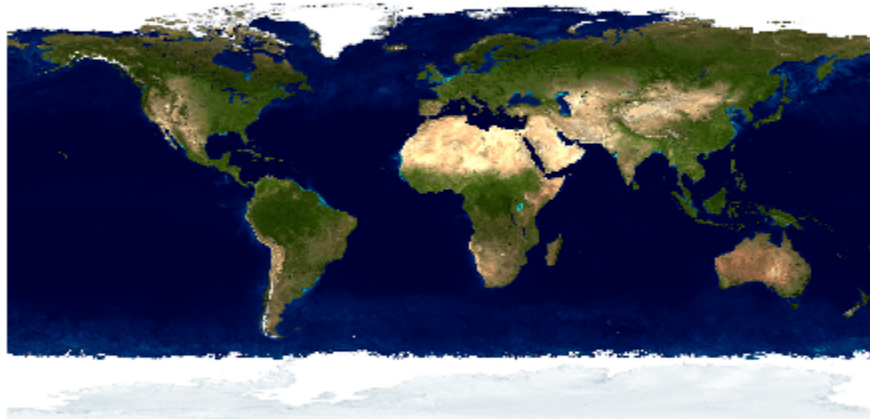

```
figure
imshow(dataV, 'InitialMagnification', 'fit');
title('Maximum Average Brightness');
```

Maximum Average Brightness



See Also

`imageDatastore` | `tall` | `mapreduce`

Related Examples

- “Tall Arrays for Out-of-Memory Data” on page 13-146
- “Getting Started with MapReduce” on page 13-3
- “Compute Maximum Average HSV of Images with MapReduce” on page 13-80

Read and Analyze MAT-File with Key-Value Data

This example shows how to create a datastore for key-value pair data in a MAT-file that is the output of `mapreduce`. Then, the example shows how to read all the data in the datastore and sort it. This example assumes that the data in the MAT-file fits in memory.

Create a datastore from the sample file, `mapredout.mat`, using the `datastore` function. The sample file contains unique keys representing airline carrier codes and corresponding values that represent the number of flights operated by that carrier.

```
ds = datastore('mapredout.mat');
```

`datastore` returns a `KeyValueDatastore`. The `datastore` function automatically determines the appropriate type of datastore to create.

Preview the data using the `preview` function. This function does not affect the state of the datastore.

```
preview(ds)
```

```
ans=1x2 table
```

Key	Value
{'AA'}	{[14930]}

Read all of the data in `ds` using the `readall` function. The `readall` function returns a table with two columns, `Key` and `Value`.

```
T = readall(ds)
```

```
T=29x2 table
```

Key	Value
{'AA' }	{[14930]}
{'AS' }	{[2910]}
{'CO' }	{[8138]}
{'DL' }	{[16578]}
{'EA' }	{[920]}
{'HP' }	{[3660]}
{'ML (1)'} }	{[69]}
{'NW' }	{[10349]}
{'PA (1)'} }	{[318]}
{'PI' }	{[871]}
{'PS' }	{[83]}
{'TW' }	{[3805]}
{'UA' }	{[13286]}
{'US' }	{[13997]}
{'WN' }	{[15931]}
{'AQ' }	{[154]}
⋮	

`T` contains all the airline and flight data from the datastore in the same order in which the data was read. The table variables, `Key` and `Value`, are cell arrays.

Convert `Value` to a numeric array.

```
T.Value = cell2mat(T.Value)
```

```
T=29x2 table
      Key      Value
      -----
      {'AA'    }    14930
      {'AS'    }     2910
      {'CO'    }     8138
      {'DL'    }    16578
      {'EA'    }     920
      {'HP'    }    3660
      {'ML (1)'}     69
      {'NW'    }   10349
      {'PA (1)'}    318
      {'PI'    }     871
      {'PS'    }     83
      {'TW'    }    3805
      {'UA'    }   13286
      {'US'    }   13997
      {'WN'    }   15931
      {'AQ'    }    154
      ⋮
```

Assign new names to the table variables.

```
T.Properties.VariableNames = {'Airline','NumFlights'};
```

Sort the data in `T` by the number of flights.

```
T = sortrows(T, 'NumFlights', 'descend')
```

```
T=29x2 table
      Airline      NumFlights
      -----
      {'DL'}      16578
      {'WN'}      15931
      {'AA'}      14930
      {'US'}      13997
      {'UA'}      13286
      {'NW'}      10349
      {'CO'}      8138
      {'MQ'}      3962
      {'TW'}      3805
      {'HP'}      3660
      {'OO'}      3090
      {'AS'}      2910
      {'XE'}      2357
      {'EV'}      1699
      {'OH'}      1457
      {'FL'}      1263
      ⋮
```

View a summary of the sorted table.

```
summary(T)
```

```
Variables:
```

```
  Airline: 29x1 cell array of character vectors
```

```
  NumFlights: 29x1 double
```

```
  Values:
```

```
      Min           69  
     Median        1457  
      Max          16578
```

Reset the datastore to allow rereading of the data.

```
reset(ds)
```

See Also

[datastore](#) | [KeyValueDatastore](#) | [tall](#) | [mapreduce](#)

Related Examples

- “Tall Arrays for Out-of-Memory Data” on page 13-146
- “Getting Started with MapReduce” on page 13-3

Read and Analyze Hadoop Sequence File

This example shows how to create a datastore for a Sequence file containing key-value data. Then, you can read and process the data one block at a time. Sequence files are outputs of mapreduce operations that use Hadoop.

Set the appropriate environment variable to the location where Hadoop is installed. In this case, set the `MATLAB_HADOOP_INSTALL` environment variable.

```
setenv('MATLAB_HADOOP_INSTALL','/mypath/hadoop-folder')
```

hadoop-folder is the folder where Hadoop is installed and *mypath* is the path to that folder.

Create a datastore from the sample file, `mapredout.seq`, using the `datastore` function. The sample file contains unique keys representing airline carrier codes and corresponding values that represent the number of flights operated by that carrier.

```
ds = datastore('mapredout.seq')
```

```
ds =
  KeyValueDatastore with properties:
    Files: {
        '...\matlab\toolbox\matlab\demos\mapredout.seq'
    }
    ReadSize: 1 key-value pairs
    FileType: 'seq'
```

`datastore` returns a `KeyValueDatastore`. The `datastore` function automatically determines the appropriate type of datastore to create.

Set the `ReadSize` property to six so that each call to `read` reads at most six key-value pairs.

```
ds.ReadSize = 6;
```

Read subsets of the data from `ds` using the `read` function in a `while` loop. For each subset of data, compute the sum of the values. Store the sum for each subset in an array named `sums`. The `while` loop executes until `hasdata(ds)` returns `false`.

```
sums = [];
while hasdata(ds)
    T = read(ds);
    T.Value = cell2mat(T.Value);
    sums(end+1) = sum(T.Value);
end
```

View the last subset of key-value pairs read.

```
T
```

```
T =
```

Key	Value
'WN'	15931
'XE'	2357

```
'YV'          849
'ML (1)'      69
'PA (1)'     318
```

Compute the total number of flights operated by all carriers.

```
numflights = sum(sums)
```

```
numflights =
```

```
123523
```

See Also

`datastore | KeyValueDatastore | mapreduce | tall`

Related Examples

- “Getting Started with MapReduce” on page 13-3
- “Tall Arrays for Out-of-Memory Data” on page 13-146

Develop Custom Datastore

This topic shows how to implement a custom datastore for file-based data. Use this framework only when writing your own custom datastore interface. Otherwise, for standard file formats, such as images or spreadsheets, use an existing datastore from MATLAB. For more information, see “Getting Started with Datastore” on page 13-86.

Overview

To build your custom datastore interface, use the custom datastore classes and objects. Then, use the custom datastore to bring your data into MATLAB and leverage the MATLAB big data capabilities such as `tall`, `mapreduce`, and Hadoop.

Designing your custom datastore involves inheriting from one or more abstract classes and implementing the required methods. The specific classes and methods you need depend on your processing needs.

Processing Needs	Classes
Datastore for Serial Processing in MATLAB	<code>matlab.io.Datastore</code> See “Implement Datastore for Serial Processing” on page 13-110
Datastore with support for Parallel Computing Toolbox and MATLAB Parallel Server	<code>matlab.io.Datastore</code> and <code>matlab.io.datastore.Partitionable</code> See “Add Support for Parallel Processing” on page 13-112
Datastore with support for Hadoop	<code>matlab.io.Datastore</code> and <code>matlab.io.datastore.HadoopLocationBased</code> See “Add Support for Hadoop” on page 13-113
Datastore with support for shuffling samples in a datastore in random order	<code>matlab.io.Datastore</code> and <code>matlab.io.datastore.Shuffleable</code> See “Add Support for Shuffling” on page 13-114
Datastore with support for writing files via <code>writeall</code>	<code>matlab.io.Datastore</code> and <code>matlab.io.datastore.FileWritable</code> (Optionally, inheriting from <code>matlab.io.datastore.FoldersPropertyProvider</code> adds support for a <code>Folders</code> property.) See “Add Support for Writing Data” on page 13-115

Start by implementing datastore for serial processing, and then add support for parallel processing, Hadoop, shuffling, or writing.

Implement Datastore for Serial Processing

To implement a custom datastore named `MyDatastore`, create a script `MyDatastore.m`. The script must be on the MATLAB path and should contain code that inherits from the appropriate class and defines the required methods. The code for creating a datastore for serial processing in MATLAB must:

- Inherit from the base class `matlab.io.Datastore`.
- Define these methods: `hasdata`, `read`, `reset`, and `progress`.
- Define additional properties and methods based on your data processing and analysis needs.

For a sample implementation, follow these steps.

Steps	Implementation
Inherit from the base class <code>Datastore</code> .	<pre> classdef MyDatastore < matlab.io.Datastore properties (Access = private) CurrentFileIndex double FileSet matlab.io.datastore.DsFileSet end % Property to support saving, loading, and processing of % datastore on different file system machines or clusters. % In addition, define the methods get.AlternateFileSystemRoots() % and set.AlternateFileSystemRoots() in the methods section. properties(Dependent) AlternateFileSystemRoots end </pre>
Add this property to create a datastore on one machine that works seamlessly on another machine or cluster that possibly has a different file system or operating system.	
Add methods to get and set this property in the methods section.	
Implement the function <code>MyDatastore</code> that creates the custom datastore.	<pre> methods % begin methods section function myds = MyDatastore(location,altRoots) myds.FileSet = matlab.io.datastore.DsFileSet(location,... 'FileExtensions','.bin', ... 'FileSplitSize',8*1024); myds.CurrentFileIndex = 1; if nargin == 2 myds.AlternateFileSystemRoots = altRoots; end reset(myds); end function tf = hasdata(myds) % Return true if more data is available. tf = hasfile(myds.FileSet); end </pre>
Implement the <code>hasdata</code> method.	

Steps	Implementation
Implement the read method.	<pre>function [data,info] = read(myds) % Read data and information about the extracted data. if ~hasdata(myds) error(sprintf(['No more data to read.\nUse the reset ',... 'method to reset the datastore to the start of ',... 'the data. \nBefore calling the read method, ',... 'check if data is available to read ',... 'by using the hasdata method.'])) end fileInfoTbl = nextfile(myds.FileSet); data = MyFileReader(fileInfoTbl); info.Size = size(data); info.FileName = fileInfoTbl.FileName; info.Offset = fileInfoTbl.Offset; % Update CurrentFileIndex for tracking progress if fileInfoTbl.Offset + fileInfoTbl.SplitSize >= ... fileInfoTbl.FileSize myds.CurrentFileIndex = myds.CurrentFileIndex + 1 ; end end</pre>
This method uses MyFileReader, which is a function that you must create to read your proprietary file format .	
See “Create Function to Read Your Proprietary File Format” on page 13-112.	
Implement the reset method.	<pre>function reset(myds) % Reset to the start of the data. reset(myds.FileSet); myds.CurrentFileIndex = 1; end</pre>
Define the methods to get and set the AlternateFileSystemRoots property.	<pre>% Before defining these methods, add the AlternateFileSystemRoots % property in the properties section % Getter for AlternateFileSystemRoots property function altRoots = get.AlternateFileSystemRoots(myds) altRoots = myds.FileSet.AlternateFileSystemRoots; end</pre>
You must reset the datastore in the set method.	<pre>% Setter for AlternateFileSystemRoots property function set.AlternateFileSystemRoots(myds,altRoots) try % The DsFileSet object manages the AlternateFileSystemRoots % for your datastore myds.FileSet.AlternateFileSystemRoots = altRoots; % Reset the datastore reset(myds); catch ME throw(ME); end end</pre>
Implement the progress method.	<pre>methods (Hidden = true) function frac = progress(myds) % Determine percentage of data read from datastore if hasdata(myds) frac = (myds.CurrentFileIndex-1)/... myds.FileSet.NumFiles; else frac = 1; end end end</pre>

Steps	Implementation
Implement the <code>copyElement</code> method when you use the <code>DsFileSet</code> object as a property in your datastore.	<pre> methods (Access = protected) % If you use the DsFileSet object as a property, then % you must define the copyElement method. The copyElement % method allows methods such as readall and preview to % remain stateless function dscopy = copyElement(ds) dscopy = copyElement@matlab.mixin.Copyable(ds); dscopy.FileSet = copy(ds.FileSet); end end </pre>
End the <code>classdef</code> section.	<pre> end </pre>

Create Function to Read Your Proprietary File Format

The implementation of the `read` method of your custom datastore uses a function called `MyFileReader`. You must create this function to read your custom or proprietary data. Build this function using `DsFileReader` object and its methods. For instance, create a function that reads binary files.

```

function data = MyFileReader(fileInfoTbl)
% create a reader object using the FileName
reader = matlab.io.datastore.DsFileReader(fileInfoTbl.FileName);

% seek to the offset
seek(reader, fileInfoTbl.Offset, 'Origin', 'start-of-file');

% read fileInfoTbl.SplitSize amount of data
data = read(reader, fileInfoTbl.SplitSize);
end

```

Add Support for Parallel Processing

To add support for parallel processing with Parallel Computing Toolbox and MATLAB Parallel Server, update your implementation code in `MyDatastore.m` to:

- Inherit from an additional class `matlab.io.datastore.Partitionable`.
- Define two additional methods: `maxpartitions` and `partition`.

For a sample implementation, follow these steps.

Steps	Implementation
Update the <code>classdef</code> section to inherit from the <code>Partitionable</code> class.	<pre> classdef MyDatastore < matlab.io.Datastore & ... matlab.io.datastore.Partitionable . . . </pre>

Steps	Implementation
Add the definition for partition to the methods section.	<pre> methods . . . function subds = partition(myds,n,ii) subds = copy(myds); subds.FileSet = partition(myds.FileSet,n,ii); reset(subds); end end </pre>
Add definition for maxpartitions to the methods section.	<pre> methods (Access = protected) function n = maxpartitions(myds) n = maxpartitions(myds.FileSet); end end </pre>
End classdef.	<pre> end </pre>

Add Support for Hadoop

To add support for Hadoop, update your implementation code in `MyDatastore.m` to:

- Inherit from an additional class `matlab.io.datastore.HadoopLocationBased`.
- Define two additional methods: `getLocation` and `initializeDatastore`.

For a sample implementation, follow these steps.

Steps	Implementation
Update the classdef section to inherit from the <code>HadoopLocationBased</code> class.	<pre> classdef MyDatastore < matlab.io.Datastore & ... matlab.io.datastore.HadoopLocationBased . . . </pre>

Steps	Implementation
Add the definition for <code>getLocation</code> , <code>initializeDatastore</code> , and <code>isfullfile</code> (optional) to the methods section.	<pre> methods (Hidden = true) . . . function initializeDatastore(myds,hadoopInfo) import matlab.io.datastore.DsFileSet; myds.FileSet = DsFileSet(hadoopInfo,... 'FileSplitSize',myds.FileSet.FileSplitSize); reset(myds); end function loc = getLocation(myds) loc = myds.FileSet; end % isfullfile method is optional function tf = isfullfile(myds) tf = isequal(myds.FileSet.FileSplitSize,'file'); end end </pre>
End the <code>classdef</code> section.	<pre> end </pre>

Add Support for Shuffling

To add support for shuffling, update your implementation code in `MyDatastore.m` to:

- Inherit from an additional class `matlab.io.datastore.Shuffleable`.
- Define the additional method `shuffle`.

For a sample implementation, follow these steps.

Steps	Implementation
Update the <code>classdef</code> section to inherit from the <code>Shuffleable</code> class.	<pre> classdef MyDatastore < matlab.io.Datastore & ... matlab.io.datastore.Shuffleable . . . </pre>

Steps	Implementation
Add the definition for shuffle to the existing methods section.	<pre> methods % previously defined methods . . . function dsNew = shuffle(ds) % dsNew = shuffle(ds) shuffles the files and the % corresponding labels in the datastore. % Create a copy of datastore dsNew = copy(ds); dsNew.Datastore = copy(ds.Datastore); fds = dsNew.Datastore; % Shuffle files and corresponding labels numObservations = dsNew.NumObservations; idx = randperm(numObservations); fds.Files = fds.Files(idx); dsNew.Labels = dsNew.Labels(idx); end end </pre>
End the classdef section.	<pre> end </pre>

Add Support for Writing Data

To add support for writing data, update your implementation code in `MyDatastore.m` to follow these requirements:

- Inherit from an additional class `matlab.io.datastore.FileWritable`.
- Initialize the properties `SupportedOutputFormats` and `DefaultOutputFormat`.
- Implement a `write` method if the datastore writes data to a custom format.
- Implement a `getFiles` method if the datastore does not have a `Files` property.
- Implement a `getFolders` method if the datastore does not have a `Folders` property.
- The output location is validated as a string. If your datastore requires further validation, you must implement a `validateOutputLocation` method.
- If the datastore is meant for files that require multiple reads per file, then you must implement the methods `getCurrentFilename` and `currentFileIndexComparator`.
- Optionally, inherit from another class `matlab.io.datastore.FoldersPropertyProvider` to add support for a `Folders` property (and thus the `FolderLayout` name-value pair of `writeall`). If you do this, then you can use the `populateFoldersFromLocation` method in the datastore constructor to populate the `Folders` property.
- To add support for the `'UseParallel'` option of `writeall`, you must subclass from both `matlab.io.datastore.FileWritable` and `matlab.io.datastore.Partitionable` and implement a `partition` method in the subclass that supports the syntax `partition(ds, 'Files', index)`.

For a sample implementation that inherits from `matlab.io.datastore.FileWritable`, follow these steps.

Steps	Implementation
Update the <code>classdef</code> section to inherit from the <code>FileWritable</code> class.	<pre>classdef MyDatastore < matlab.io.Datastore & ... matlab.io.datastore.FileWritable . . .</pre>
Initialize the properties <code>SupportedOutputFormats</code> and <code>DefaultOutputFormat</code> . In this example, the datastore supports all of the output formats of <code>ImageDatastore</code> , as well as a custom format "dcm", which is also declared as the default output format.	<pre>properties (Constant) SupportedOutputFormats = ... [matlab.io.datastore.ImageDatastore.SupportedOutputFormats, "dcm"]; DefaultOutputFormat = "dcm"; end</pre>
Add definitions for <code>getFiles</code> and <code>getFolders</code> to the existing methods section. These methods are required when the datastore does not have <code>Files</code> or <code>Folders</code> properties.	<pre>methods (Access = protected) function files = getFiles(ds) files = {'data/folder/file1', 'data/folder/file2',...}; end function folders = getFolders(ds) folders = {'data/folder1/', 'data/folder2/',...}; end end</pre>
Add a write method when the datastore intends to write data to a custom format. In this example, the method switches between using a custom write function for "dcm" and the built-in write function for known formats.	<pre>methods(Access = protected) function tf = write(myds, data, writeInfo, outFmt, varargin) if outFmt == "dcm" % use custom write fcn for dcm format dicomwrite(data, writeInfo.SuggestedOutputName, varargin{:}); else % callback into built-in for known formats write@matlab.io.datastore.FileWritable(myds, data, ... writeInfo, outFmt, varargin{:}); end tf = true; end end</pre>
End the <code>classdef</code> section.	<pre>end</pre>

For a longer example class that inherits from both `matlab.io.datastore.FileWritable` and `matlab.io.datastore.FoldersPropertyProvider`, see “Develop Custom Datastore for DICOM Data” on page 13-126.

Validate Custom Datastore

After following the instructions presented here, the implementation step of your custom datastore is complete. Before using this custom datastore, qualify it using the guidelines presented in “Testing Guidelines for Custom Datastores” on page 13-118.

See Also

`matlab.io.Datastore` | `matlab.io.datastore.Partitionable` |
`matlab.io.datastore.HadoopLocationBased` | `matlab.io.datastore.Shuffleable` |
`matlab.io.datastore.DsFileSet` | `matlab.io.datastore.DsFileReader` |
`matlab.io.datastore.FoldersPropertyProvider` | `matlab.io.datastore.FileWritable`

More About

- “Developing Classes That Work Together”
- “Create and Share Toolboxes”
- “Create Help for Classes”
- “Develop Custom Datastore for DICOM Data” on page 13-126

Testing Guidelines for Custom Datastores

All datastores that are derived from the custom datastore classes share some common behaviors. This test procedure provides guidelines to test the minimal set of behaviors and functionalities that all custom datastores should have. You will need additional tests to qualify any unique functionalities of your custom datastore.

If you have developed your custom datastore based on instructions in “Develop Custom Datastore” on page 13-109, then follow these test procedures to qualify your custom datastore. First perform the unit tests, followed by the workflow tests:

- Unit tests qualify the datastore constructor and methods.
- Workflow tests qualify the datastore usage.

For all these test cases:

- Unless specified in the test description, assume that you are testing a nonempty datastore `ds`.
- Verify the test cases on the file extensions, file encodings, and data locations (like Hadoop) that your custom datastore is designed to support.

Unit Tests

Construction

The unit test guidelines for the datastore constructor are as follows.

Test Case Description	Expected Output
Check if your custom datastore constructor works with the minimal required inputs.	Datastore object of your custom datastore type with the minimal expected properties and methods
Check if your datastore object <code>ds</code> has <code>matlab.io.Datastore</code> as one of its superclasses.	1 or true
Run this command: <code>isa(ds, 'matlab.io.Datastore')</code>	
Call your custom datastore constructor with the required inputs and any supported input arguments and name-value pair arguments.	Datastore object of your custom datastore type with the minimal expected properties and methods

read

Unit test guidelines for the `read` method

Test Case Description	Expected Output
Call the <code>read</code> method on a datastore object <code>ds</code> . <code>t = read(ds);</code>	Data from the beginning of the datastore If you specify read size, then the size of the returned data is equivalent to read size.

Test Case Description	Expected Output
Call the read method again on the datastore object. <code>t = read(ds);</code>	Data starting from the end point of the previous read operation If you specify read size, then the size of the returned data is equivalent to read size.
Continue calling the read method on the datastore object in a while loop. <code>while(hasdata(ds))</code> <code>t = read(ds);</code> <code>end</code>	No errors Correct data in the correct format
When data is available to read, check the info output (if any) of the read method. Call a datastore object <code>ds</code> . <code>[t,info] = read(ds);</code>	No error <code>info</code> contains the expected information <code>t</code> contains the expected data
When no more data is available to read, call read on the datastore object.	Either expected output or an error message based on your custom datastore implementation.

readall

Unit test guidelines for the readall method

Test Case Description	Expected Output
Call the readall method on the datastore object.	All data
Call the readall method on the datastore object, when <code>hasdata(ds)</code> is false.	All data
Read from the datastore until <code>hasdata(ds)</code> is false, and then call the readall method. <code>while(hasdata(ds))</code> <code>t = read(ds);</code> <code>end</code> <code>readall(ds)</code>	

hasdata

Unit test guidelines for the hasdata method

Test Case Description	Expected Output
Call the hasdata method on the datastore object before making any calls to read	true
Call the hasdata method on the datastore object after making a few calls to read, but before all the data is read	true

Test Case Description	Expected Output
When more data is available to read, call the <code>readall</code> method, and then call the <code>hasdata</code> method.	<code>true</code>
When no more data is available to read, call the <code>hasdata</code> method.	<code>false</code>

reset

Unit test guidelines for the `reset` method

Test Case Description	Expected Output
Call the <code>reset</code> method on the datastore object before making any calls to the <code>read</code> method.	No errors
Verify that the <code>read</code> method returns the appropriate data after a call to the <code>reset</code> method.	The <code>read</code> returns data from the beginning of the datastore.
<code>reset(ds);</code> <code>t = read(ds);</code>	If you specify read size, then the size of the returned data is equivalent to read size.
When more data is available to read, call the <code>reset</code> method after making a few calls to the <code>read</code> method.	No errors
Verify that the <code>read</code> method returns the appropriate data after making a call to the <code>reset</code> method.	The <code>read</code> method returns data from the beginning of the datastore.
	If you specify read size, then the size of the returned data is equivalent to read size.
When more data is available to read, call the <code>reset</code> method after making a call to the <code>readall</code> method.	No errors
Verify that the <code>read</code> method returns the appropriate data after making a call to the <code>reset</code> method.	The <code>read</code> method returns data from the beginning of the datastore.
	If you specify read size, then the size of the returned data is equivalent to read size.
When no more data is available to read, call the <code>reset</code> method on the datastore object and then call the <code>read</code> method	No errors
Verify that <code>read</code> returns the appropriate data after a call to the <code>reset</code> method.	The <code>read</code> method returns data from the beginning of the datastore.
	If you specify read size, then the size of the returned data is equivalent to read size.

progress

Unit test guidelines for the `progress` method

Test Case Description	Expected Output
Call the <code>progress</code> method on the datastore object before making any calls to the <code>read</code> method.	0 or an expected output based on your custom datastore implementation.

Test Case Description	Expected Output
<p>Call the <code>progress</code> method on the datastore object after making a call to <code>readall</code>, but before making any calls to <code>read</code></p> <pre>readall(ds); progress(ds)</pre>	0 or an expected output based on your custom datastore implementation.
<p>Call the <code>progress</code> method on the datastore object after making a few calls to <code>read</code> and while more data is available to read.</p>	A fraction between 0 and 1 or an expected output based on your custom datastore implementation.
<p>Call the <code>progress</code> method on the datastore object when no more data is available to read.</p>	1 or an expected output based on your custom datastore implementation.

preview

Unit test guidelines for the `preview` method

Test Case Description	Expected Output
<p>Call <code>preview</code> on the datastore object before making any calls to <code>read</code>.</p>	The <code>preview</code> method returns the expected data from the beginning of the datastore, based on your custom datastore implementation.
<p>Call <code>preview</code> on the datastore object after making a few calls to <code>read</code> and while more data is available to read.</p>	The <code>preview</code> method returns the expected data from the beginning of the datastore, based on your custom datastore implementation.
<p>Call <code>preview</code> on the datastore object after making a call to <code>readall</code> and while more data is available to read.</p>	The <code>preview</code> method returns the expected data from the beginning of the datastore, based on your custom datastore implementation.
<p>Call <code>preview</code> on the datastore object after making a few calls to <code>read</code> and a call to <code>reset</code>.</p>	The <code>preview</code> method returns the expected data from the beginning of the datastore, based on your custom datastore implementation.
<p>Call <code>preview</code> on the datastore object when no more data is available to read.</p>	The <code>preview</code> method returns the expected data from the beginning of the datastore, based on your custom datastore implementation.
<p>Call <code>preview</code> after making a few calls to <code>read</code> method and then call <code>read</code> again.</p>	<p>The <code>read</code> method returns data starting from the end point of the previous <code>read</code> operation.</p> <p>If you specify <code>read size</code>, then the size of the returned data is equivalent to <code>read size</code>.</p>
<p>Call <code>preview</code>, and then call <code>readall</code> on the datastore.</p>	The <code>readall</code> method returns all the data from the datastore.

Test Case Description	Expected Output
While datastore has data available to read, call <code>preview</code> , and then call <code>hasdata</code> .	The <code>hasdata</code> method returns <code>true</code> .

partition

Unit test guidelines for the `partition` method

Test Case Description	Expected Output
Call <code>partition</code> on the datastore object <code>ds</code> with a valid number of partitions and a valid partition index.	The <code>partition</code> method partitions the datastore into <code>n</code> partitions and returns the partition corresponding to the specified <code>index</code> .
Call <code>read</code> on a partition of the datastore and verify the data.	The returned partition <code>subds</code> must be a datastore object of your custom datastore.
<pre>subds = partition(ds,n,index) read(subds)</pre>	The partitioned datastore <code>subds</code> must have the same methods and properties as the original datastore.
Verify that the partition is valid.	The <code>isequal</code> statement returns <code>true</code> .
<pre>isequal(properties(ds),properties(subds)) isequal(methods(ds),methods(subds))</pre>	Calling <code>read</code> on the partition returns data starting from the beginning of the partition.
Call <code>partition</code> on the datastore object <code>ds</code> with number of partitions specified as 1 and <code>index</code> of returned partition specified as 1.	If you specify <code>read size</code> , then the size of the returned data is equivalent to <code>read size</code> .
Verify the data returned by calling <code>read</code> and <code>preview</code> on a partition of the partitioned datastore.	The partition <code>subds</code> must be a datastore object of your custom datastore.
<pre>subds = partition(ds,1,1) isequal(properties(ds),properties(subds)) isequal(methods(ds),methods(subds)) isequaln(read(subds),read(ds)) isequaln(preview(subds),preview(ds))</pre>	The partition <code>subds</code> must have the same methods and properties as the original datastore <code>ds</code> .
Call <code>partition</code> on the partition <code>subds</code> with a valid number of partitions and a valid partition index.	The <code>isequal</code> and <code>isequaln</code> statements returns <code>true</code> .
	The repartitioning of a partition of the datastore should work without errors.

initializeDatastore

If your datastore inherits from `matlab.io.datastore.HadoopFileBased`, then verify the behavior of `initializeDatastore` using the guidelines in this table.

Test Case Description	Expected Output
<p>Call <code>initializeDatastore</code> on the datastore object <code>ds</code> with a valid <code>info</code> struct.</p> <p>The <code>info</code> struct contains these fields:</p> <ul style="list-style-type: none"> • <code>FileName</code> • <code>Offset</code> • <code>Size</code> <p><code>FileName</code> is of data type <code>char</code> and the fields <code>Offset</code> and <code>Size</code> are of the data type <code>double</code>.</p> <p>For example, initialize the <code>info</code> struct, and then call <code>initializeDatastore</code> on the datastore object <code>ds</code>.</p> <pre>info = struct('FileName','myFileName.ext',... 'Offset',0,'Size',500) initializeDatastore(ds,info)</pre> <p>Verify the initialization by examining the properties of your datastore object.</p> <p><code>ds</code></p>	<p>The <code>initializeDatastore</code> method initializes the custom datastore object <code>ds</code> with the necessary information from the <code>info</code> struct.</p>

getLocation

If your datastore inherits from `matlab.io.datastore.HadoopFileBased`, then verify the behavior of `getLocation` using these guidelines.

Test Case Description	Expected Output
<p>Call <code>getLocation</code> on the datastore object.</p> <pre>location = getLocation(ds)</pre> <p>Based on your custom datastore implementation, the <code>location</code> output is either of these:</p> <ul style="list-style-type: none"> • List of files or directories • a <code>matlab.io.datastore.DsFileSet</code> object <p>If <code>location</code> is a <code>matlab.io.datastore.DsFileSet</code> object, then call <code>resolve</code> to verify the files in the <code>location</code> output.</p> <pre>resolve(location)</pre>	<p>The <code>getLocation</code> method returns the location of files in Hadoop.</p>

isfullfile

If your datastore inherits from `matlab.io.datastore.HadoopFileBased`, then verify the behavior of `isfullfile` using these guidelines.

Test Case Description	Expected Output
Call <code>isfullfile</code> on the datastore object.	Based on your custom datastore implementation, the <code>isfullfile</code> method returns <code>true</code> or <code>false</code> .

Workflow Tests

Verify your workflow tests in the appropriate environment.

- If your datastore inherits only from `matlab.io.Datastore`, then verify all workflow tests in a local MATLAB session.
- If your datastore has parallel processing support (inherits from `matlab.io.datastore.Partitionable`), then verify your workflow tests in parallel execution environments, such as Parallel Computing Toolbox and MATLAB Parallel Server.
- If your datastore has Hadoop support (inherits from `matlab.io.datastore.HadoopFileBased`), then verify your workflow tests in a Hadoop cluster.

Tall Workflow

Testing guidelines for the tall workflow

Test Case Description	Expected Output
Create a tall array by calling <code>tall</code> on the datastore object <code>ds</code> . <code>t = tall(ds)</code>	The <code>tall</code> function returns an output that is the same data type as the output of the <code>read</code> method of the datastore.
For this test step, create a datastore object with data that fits in your system memory. Then, create a tall array using this datastore object. <code>t = tall(ds)</code>	No errors The function returns an output of the correct data type (not of a tall data type).
If your data is numeric, then apply an appropriate function like the <code>mean</code> function to both the <code>ds</code> and <code>t</code> , then compare the results.	The function returns the same result whether it is applied to <code>ds</code> or to <code>t</code> .
If your data is of the data type <code>string</code> or <code>categorical</code> , then apply the <code>unique</code> function on a column of <code>ds</code> and a column of <code>t</code> , then compare the results.	
Apply <code>gather</code> and verify the result.	
For examples, see “Big Data Workflow Using Tall Arrays and Datastores” (Parallel Computing Toolbox).	

MapReduce Workflow

Testing guidelines for the MapReduce workflow

Test Case Description	Expected Output
Call <code>mapreduce</code> on the datastore object <code>ds</code> .	No error
<code>outds = mapreduce(ds,@mapper,@reducer)</code>	The MapReduce operation returns the expected result
For more information, see <code>mapreduce</code> .	
To support the use of the <code>mapreduce</code> function, the <code>read</code> method of your custom datastore must return both the <code>info</code> and the <code>data</code> output arguments.	

Next Steps

Note This test procedure provides guidelines to test the minimal set of behaviors and functionalities for custom datastores. Additional tests are necessary to qualify any unique functionalities of your custom datastore.

After you complete the implementation and validation of your custom datastore, your custom datastore is ready to use.

- To add help for your custom datastore implementation, see “Create Help for Classes”.
- To share your custom datastore with other users, see “Create and Share Toolboxes”.

See Also

`matlab.io.Datastore` | `matlab.io.datastore.Partitionable` | `matlab.io.datastore.HadoopLocationBased`

More About

- “Develop Custom Datastore” on page 13-109
- “Create and Share Toolboxes”
- “Create Help for Classes”

Develop Custom Datastore for DICOM Data

This example shows how to develop a custom datastore that supports writing operations. The datastore is named `DICOMDatastore` because it supports DICOM® (Digital Imaging and Communications in Medicine) data, which is an international standard for medical imaging information.

Developing Custom Datastores

The topic “Develop Custom Datastore” on page 13-109 describes the general process for creating a custom datastore, as well as the specific requirements to add different pieces of functionality. There are a variety of superclasses you can subclass from depending on what pieces of functionality you need (parallel evaluation, writing operations, shuffling, and so on). In particular, you can add support for writing operations by subclassing from `matlab.io.datastore.FileWritable`. However, for the broadest set of writing functionality, you must also subclass from `matlab.io.datastore.FoldersPropertyProvider`, which adds a `Folders` property to the datastore. The complete requirements to add writing support to a custom datastore are covered in “Add Support for Writing Data” on page 13-115.

Class Definition

This table contains code and explanations for the `DICOMDatastore` class.

<pre>classdef DICOMDatastore < matlab.io.Datastore matlab.io.datastore.FileWritable & ... matlab.io.datastore.FoldersPropertyProvider end</pre>	<p>Class Header</p> <p><code>DICOMDatastore</code> inherits from <code>Datastore</code> for basic functionality, as well as from <code>FileWritable</code> and <code>FoldersPropertyProvider</code> to enable file writing capabilities.</p>
<pre>properties Files matlab.io.datastore.FileSet end</pre>	<p>Public Properties</p> <p><code>DICOMDatastore</code> defines a public <code>Files</code> property that is a <code>FileSet</code> object. <code>DICOMDatastore</code> inherits a <code>Folders</code> property from <code>FoldersPropertyProvider</code>, so that property does not need to be initialized.</p>
<pre>properties (Constant) SupportedOutputFormats = ... [matlab.io.datastore.ImageDatastore.SupportedOutputFormats, "dcm"]; DefaultOutputFormat = "dcm"; end</pre>	<p><code>DICOMDatastore</code> defines <code>SupportedOutputFormats</code> and <code>DefaultOutputFormat</code> as constant properties with default values. "dcm" is a custom format for DICOM data.</p>

<pre> methods(Access = public) function myds = DICOMDatastore(location) % The class constructor to set the properties of the datastore myds.Files = matlab.io.datastore.FileSet(location, ... "IncludeSubfolders", true); populateFoldersFromLocation(myds, location); reset(myds); end </pre>	<p>Public Methods</p> <p>The public methods section defines common properties of the datastore methods that the class uses to manipulate data. Public methods are externally accessible, so class users of <code>DICOMDatastore</code> can call these methods (in addition to other public methods inherited from the superclasses).</p> <p>The constructor <code>DICOMDatastore</code> creates a new <code>DICOMDatastore</code> object by setting values for the <code>Files</code> and <code>Folders</code> properties.</p> <ul style="list-style-type: none"> • Use <code>FileSet</code> to set the value of the <code>Files</code> property. • Use the <code>populateFoldersFromLocation</code> method of <code>FoldersPropertyProvider</code> to set the value of the <code>Folders</code> property.
<pre> function tf = hasdata(myds) %HASDATA Returns true if more data is available % Return logical scalar indicating availability of data % This method should be called before calling read. This % is an abstract method and must be implemented by the % subclasses. hasdata is used in conjunction with read to % read all the data within the datastore. tf = hasNextFile(myds.Files); end </pre>	<p>The <code>hasdata</code>, <code>read</code>, <code>reset</code>, and <code>progress</code> methods define the infrastructure for the datastore to work with small chunks of data at a time. These are abstract methods that must be implemented by the subclass.</p>
<pre> function [data, info] = read(myds) %READ Read data and information about the extracted data. % Return the data extracted from the datastore in the % appropriate form for this datastore. Also return % information about where the data was extracted from in % the datastore. Both the outputs are required to be % returned from the read method and can be of any type. % info is recommended to be a struct with information % about the chunk of data read. data represents the % underlying class of tall, if tall is created on top of % this datastore. This is an abstract method and must be % implemented by the subclasses. % In this example, the read method reads data from the % datastore using a custom reader function, MyFileReader, % which takes the resolved filenames as input. if ~hasdata(myds) error("No more data to read.\nUse reset method to " ... + "reset the datastore to the start of the data. Before " ... + "calling the read method, check if data is available " ... + "to read by using the hasdata method."); end file = nextfile(myds.Files); try data = dicomread(file.FileName); catch ME error("%s has failed", file.FileName); end info.FileSize = size(data); info.FileName = file.FileName; end </pre>	

<pre>function reset(myds) %RESET Reset to the start of the data. % Reset the datastore to the state where no data has been % read from it. This is an abstract method and must be % implemented by the subclasses. % In this example, the datastore is reset to point to the % first file (and first partition) in the datastore. reset(myds.Files); end</pre>	
<pre>function frac = progress(myds) %PROGRESS Percentage of consumed data between 0.0 and 1.0. % Return fraction between 0.0 and 1.0 indicating progress as a % double. The provided example implementation returns the % ratio of the index of the current file from FileSet % to the number of files in FileSet. A simpler % implementation can be used here that returns a 1.0 when all % the data has been read from the datastore, and 0.0 % otherwise. % % See also matlab.io.Datastore, read, hasdata, reset, readall, % preview. frac = progress(myds.Files); end</pre>	
<pre>methods(Access = protected) function dsCopy = copyElement(myds) %COPYELEMENT Create a deep copy of the datastore. We need to call % Create a deep copy of the datastore. For more % copy on the datastore's property FileSet because it is % a handle object. Creating a deep copy allows methods % such as readall and preview, which call the copy method, % to remain stateless. dsCopy = copyElement@matlab.mixin.Copyable(myds); dsCopy.Files = copy(myds.Files); end</pre>	<p>Protected Methods</p> <p>Protected methods redefine methods that were inherited by the class, and they are only accessible to DICOMDatastore. For more information, see "Modify Inherited Methods".</p> <p>The protected copyElement method is required whenever FileSet is used to define properties. The copyElement method allows methods such as readall and preview to remain stateless.</p>
<pre>function tf = write(myds, data, writeInfo, outFmt, varargin) if outFmt == "dcm" dicomwrite(data, writeInfo.SuggestedOutputName, data, ...); else write@matlab.io.datastore.FileWritable(myds, writeInfo, outFmt, varargin{:}); end tf = true; end</pre>	<p>The protected write method writes out chunks of data. Since DICOMDatastore supports ImageDatastore formats as well as the custom format "dcm", the write method uses different functions to write the data depending on the output format.</p>
<pre>function files = getFiles(myds) files = myds.Files.FileInfo.FilePaths; end</pre>	<p>The protected getFiles method is necessary since DICOMDatastore uses FileSet objects for the Files property. The Files property is generally required to return a cellstr, so the getFiles method uses the FileSet object to generate a cellstr of the file paths.</p>
<pre>end</pre>	<p>End the classdef section.</p>

Expand for Class Code

```
classdef DICOMDatastore < matlab.io.Datastore & ...
    matlab.io.datastore.FileWritable & ...
    matlab.io.datastore.FoldersPropertyProvider

    properties
        Files matlab.io.datastore.FileSet
    end
```

```

properties (Constant)
    SupportedOutputFormats = ...
        [matlab.io.datastore.ImageDatastore.SupportedOutputFormats, "dcm"];
    DefaultOutputFormat = "dcm";
end

methods(Access = public)
function myds = DICOMDatastore(location)
    % The class constructor to set properties of the datastore.
    myds.Files = matlab.io.datastore.FileSet(location, ...
        "IncludeSubfolders", true);
    populateFoldersFromLocation(myds, location);
    reset(myds);
end

function tf = hasdata(myds)
    %HASDATA Returns true if more data is available.
    % Return logical scalar indicating availability of data.
    % This method should be called before calling read. This
    % is an abstract method and must be implemented by the
    % subclasses. hasdata is used in conjunction with read to
    % read all the data within the datastore.
    tf = hasNextFile(myds.Files);
end

function [data, info] = read(myds)
    %READ Read data and information about the extracted data.
    % Return the data extracted from the datastore in the
    % appropriate form for this datastore. Also return
    % information about where the data was extracted from in
    % the datastore. Both the outputs are required to be
    % returned from the read method and can be of any type.
    % info is recommended to be a struct with information
    % about the chunk of data read. data represents the
    % underlying class of tall, if tall is created on top of
    % this datastore. This is an abstract method and must be
    % implemented by the subclasses.

    % In this example, the read method reads data from the
    % datastore using a custom reader function, MyFileReader,
    % which takes the resolved filenames as input.
    if ~hasdata(myds)
        error("No more data to read.\nUse reset method to " ...
            + "reset the datastore to the start of the data. Before " ...
            + "calling the read method, check if data is available " ...
            + "to read by using the hasdata method.");
    end

    file = nextfile(myds.Files);
    try
        data = dicomread(file.FileName);
    catch ME
        error("%s has failed", file.FileName);
    end

    info.FileSize = size(data);
    info.FileName = file.FileName;
end

function reset(myds)
    %RESET Reset to the start of the data.
    % Reset the datastore to the state where no data has been
    % read from it. This is an abstract method and must be
    % implemented by the subclasses.

    % In this example, the datastore is reset to point to the
    % first file (and first partition) in the datastore.
    reset(myds.Files);
end

function frac = progress(myds)
    %PROGRESS Percentage of consumed data between 0.0 and 1.0.
    % Return fraction between 0.0 and 1.0 indicating progress as a
    % double. The provided example implementation returns the
    % ratio of the index of the current file from FileSet
    % to the number of files in FileSet. A simpler
    % implementation can be used here that returns a 1.0 when all
    % the data has been read from the datastore, and 0.0
    % otherwise.
    %
    % See also matlab.io.Datastore, read, hasdata, reset, readall,

```

```

        % preview.
        frac = progress(myds.Files);
    end
end

methods(Access = protected)
function dsCopy = copyElement(myds)
    %COPYELEMENT Create a deep copy of the datastore
    % Create a deep copy of the datastore. We need to call
    % copy on the datastore's property FileSet because it is
    % a handle object. Creating a deep copy allows methods
    % such as readall and preview, which call the copy method,
    % to remain stateless.
    dsCopy = copyElement(@matlab.mixin.Copyable(myds);
    dsCopy.Files = copy(myds.Files);
end

function tf = write(myds, data, writeInfo, outFmt, varargin)
    if outFmt == "dcm"
        dicomwrite(data, writeInfo.SuggestedOutputName, varargin{:});
    else
        write@matlab.io.datastore.FileWritable(myds, data, ...
        writeInfo, outFmt, varargin{:});
    end
    tf = true;
end

function files = getFiles(myds)
    files = myds.Files.FileInfo.Filename;
end
end
end

```

Using the DICOMDatastore Class

After you implement the `DICOMDatastore` class, you can use the constructor to create a new `DICOMDatastore` object that references the location of a set of DICOM files. For example, if you have DICOM files in the folder `C:\Data\DICOM\series-000001\`:

```
ds = DICOMDatastore("C:\Data\DICOM\series-000001")
```

```
ds =
```

```
DICOMDatastore with properties:
```

```

        Files: [1x1 matlab.io.datastore.FileSet]
SupportedOutputFormats: ["png" "jpg" "jpeg" "tif" "tiff" "dcm"]
DefaultOutputFormat: "dcm"
        Folders: {'C:\Data\DICOM\series-000001'}
```

Class users of `DICOMDatastore` have access to these public methods:

```
methods(ds)
```

```
Methods for class DICOMDatastore:
```

```

DICOMDatastore copy isPartitionable preview read reset writeall
combine hasdata isShuffleable progress readall transform
```

```
Methods of DICOMDatastore inherited from handle.
```

In particular, with support for `writeall`, you can write the files to a new location:

```
writeall(ds, "C:\Data2\DICOM\")
```

This command creates copies of the datastore files in the folder `C:\Data2\DICOM\series-000001`.

For general information on authoring classes in MATLAB, see “Classes”.

See Also

[matlab.io.Datastore](#) | [matlab.io.datastore.FileWritable](#) |
[matlab.io.datastore.FoldersPropertyProvider](#)

More About

- “Develop Custom Datastore” on page 13-109
- “Testing Guidelines for Custom Datastores” on page 13-118

Set Up Datastore for Processing on Different Machines or Clusters

You can create and save a datastore on a platform that loads and works seamlessly on a different platform by setting up the 'AlternateFileSystemRoots' property of the datastore. Use this property when:

- You create a datastore on a local machine, and need to access and process the data on another machine (possibly running a different operating system).
- You process your datastore with parallel and distributed computing involving different platforms, cloud or cluster machines.

This example demonstrates the use of the 'AlternateFileSystemRoots' property for TabularTextDatastore. However, you can use the same syntax for any of these datastores: SpreadsheetDatastore, ImageDatastore, ParquetDatastore, FileDatastore, KeyValueDatastore, and TallDatastore. To use the 'AlternateFileSystemRoots' functionality for custom datastores, see `matlab.io.datastore.DsFileSet` and "Develop Custom Datastore" on page 13-109.

Save Datastore and Load on Different File System Platform

Create a datastore on one file system that loads and works seamlessly on a different machine (possibly of a different operating system). For example, create a datastore on a Windows machine, save it, and then load it on a Linux machine.

First, before you create and save the datastore, identify the root paths for your data on the different platforms. The root paths will differ based on the machine or file system. For instance, if you have data on your local machine and a copy of the data on a cluster, then get the root paths for accessing the data:

- "Z:\DataSet" for your local Windows machine.
- "/nfs-bldg001/DataSet" for your Linux cluster.

Then, associate these root paths by using the 'AlternateFileSystemRoots' parameter of the datastore.

```
altRoots = ["Z:\DataSet", "/nfs-bldg001/DataSet"];
ds = tabularTextDatastore('Z:\DataSet', 'AlternateFileSystemRoots', altRoots);
```

Examine the Files property of datastore. In this instance, the Files property contains the location of your data as accessed by your Windows machine.

```
ds.Files
```

```
ans =
```

```
5x1 cell array
```

```
{'Z:\DataSet\datafile01.csv'}
{'Z:\DataSet\datafile02.csv'}
{'Z:\DataSet\datafile03.csv'}
{'Z:\DataSet\datafile04.csv'}
{'Z:\DataSet\datafile05.csv'}
```

Save the datastore.

```
save ds_saved_on_Windows.mat ds
```

Load the datastore on a Linux platform and examine the Files property. Since the root path 'Z:\DataSet' is not accessible on the Linux cluster, at load time, the datastore function automatically updates the root paths based on the values specified in the 'AlternateFileSystemRoots' parameter. The Files property of the datastore now contains the updated root paths for your data on the Linux cluster.

```
load ds_saved_on_Windows.mat
ds.Files
```

```
ans =
```

```
5×1 cell array
```

```
{'/nfs-bldg001/DataSet/datafile01.csv'}
{'/nfs-bldg001/DataSet/datafile02.csv'}
{'/nfs-bldg001/DataSet/datafile03.csv'}
{'/nfs-bldg001/DataSet/datafile04.csv'}
{'/nfs-bldg001/DataSet/datafile05.csv'}
```

You can now process and analyze this datastore on your Linux machine.

Process Datastore Using Parallel and Distributed Computing

To process your datastore with parallel and distributed computing that involves different platforms, cloud or cluster machines, you must predefine the 'AlternateFileSystemRoots' parameter. This example demonstrates how to create a datastore on your local machine, analyze a small portion of the data, and then use Parallel Computing Toolbox and MATLAB Parallel Server to scale up the analysis to the entire dataset.

Create a datastore and assign a value to the 'AlternateFileSystemRoots' property. To set the value for the 'AlternateFileSystemRoots' property, identify the root paths for your data on the different platforms. The root paths differ based on the machine or file system. For example, identify the root paths for data access from your machine and your cluster:

- "Z:\DataSet" from your local Windows Machine.
- "/nfs-bldg001/DataSet" from the MATLAB Parallel Server Linux Cluster.

Then, associate these root paths using the AlternateFileSystemRoots property.

```
altRoots = ["Z:\DataSet", "/nfs-bldg001/DataSet"];
ds = tabularTextDatastore('Z:\DataSet', 'AlternateFileSystemRoots', altRoots);
```

Analyze a small portion of the data on your local machine. For instance, get a partitioned subset of the data, clean the data by removing any missing entries, and examine a plot of the variables.

```
tt = tall(partition(ds, 100, 1));
summary(tt);
% analyze your data
tt = rmmissing(tt);
plot(tt.MyVar1, tt.MyVar2)
```

Scale up your analysis to the entire dataset by using MATLAB Parallel Server cluster (Linux cluster). For instance, start a worker pool using the cluster profile, and then perform analysis on the entire dataset by using parallel and distributed computing capabilities.

```
parpool('MyMjsProfile')
tt = tall(ds);
summary(tt);
% analyze your data
tt = rmmissing(tt);
plot(tt.MyVar1,tt.MyVar2)
```

See Also

[datastore](#) | [TabularTextDatastore](#) | [SpreadsheetDatastore](#) | [ImageDatastore](#) | [FileDatastore](#) | [KeyValueDatastore](#) | [TallDatastore](#)

More About

- “Getting Started with Datastore” on page 13-86
- “Work with Remote Data” on page 13-93

Apache Parquet Data Type Mappings

MATLAB represents column-oriented data with tables and timetables. Each variable in a table or timetable can have a different data type and any number of columns. Column vectors are the most common shape of table and timetable variables.

The Apache™ Parquet file format is used for column-oriented heterogeneous data. Similar to MATLAB tables and timetables, each of the columns in a Parquet file can have different data types. The MATLAB Parquet functions use Apache Arrow functionality to read and write Parquet files. MATLAB stores the original Arrow table schema in the Parquet file as custom metadata. Arrow uses the original table schema to roundtrip certain data types.

Despite their similarity, the permitted data types in MATLAB tables and timetables sometimes do not map exactly to the permitted data types in Parquet files. In some cases, it is necessary for MATLAB to perform data type conversions to retain information in the data (such as missing values). This conversion can sometimes result in a loss of precision in the data.

In general, MATLAB tables and timetables have these behaviors when they are converted to Parquet files:

- Table properties set on the original table are not saved.
- Table row names or timetable row times are converted into a new table variable before being written.
- When reading a variable name from a Parquet file, invalid table variable names are converted to valid table variable names.

Parquet files use a small number of primitive (or *physical*) data types. The *logical* types extend the physical types by specifying how they should be interpreted. Parquet data types not covered here are not supported for reading from or writing to Parquet files (JSON, BSON, binary, and so on).

The following tables summarize the representable data types in MATLAB tables and timetables, as well as how they map to corresponding types in Apache Arrow and Parquet files.

Numeric Data Types

Reading Numeric Data Types from Apache Parquet to MATLAB

Apache Parquet Data Type		Apache Arrow Data Type	MATLAB Table or Timetable Variable Type	Notes
Logical Type	Physical Type			
None	DOUBLE	double	double	<ul style="list-style-type: none"> • Parquet data type is a 64-bit floating-point value. • MATLAB converts any null floating-point values in Parquet files to NaN values.

Apache Parquet Data Type		Apache Arrow Data Type	MATLAB Table or Timetable Variable Type	Notes
Logical Type	Physical Type			
None	FLOAT	float	single	<ul style="list-style-type: none"> Parquet data type is a 32-bit floating-point value. MATLAB converts any null floating-point values in Parquet files to NaN values.
INT <ul style="list-style-type: none"> bitWidth=8 isSigned=true 	INT32	int8	int8	<ul style="list-style-type: none"> If an array contains null values, the array is converted to a MATLAB double and null values are set to NaN. 64-bit integers are truncated when converted to doubles if values are larger in magnitude than flintmax. parquetread converts columns with null values to double arrays. parquetDatastore will import null values as the sentinel value 0.
INT <ul style="list-style-type: none"> bitWidth=8 isSigned=false 	INT32	uint8	uint8	
INT <ul style="list-style-type: none"> bitWidth=16 isSigned=true 	INT32	int16	int16	
INT <ul style="list-style-type: none"> bitWidth=16 isSigned=false 	INT32	uint16	uint16	
None	INT32	int32	int32	
INT <ul style="list-style-type: none"> bitWidth=32 isSigned=false 	INT32	uint32	uint32	
INT <ul style="list-style-type: none"> bitWidth=64 isSigned=true 	INT64	int64	int64	

Apache Parquet Data Type		Apache Arrow Data Type	MATLAB Table or Timetable Variable Type	Notes
Logical Type	Physical Type			
INT	INT64	uint64	uint64	
<ul style="list-style-type: none"> • bitWidth=64 • isSigned=false 				
None	BOOLEAN	boolean	logical	<ul style="list-style-type: none"> • If an array type BOOLEAN contains null values, then <code>parquetread</code> converts the array to the MATLAB double datatype and fills null values with NaN. • <code>parquetread</code> sets the null values to NaN. • <code>parquetDatastore</code> will import null values as the sentinel value <code>false</code>.

Writing Numeric Data Types from MATLAB to Apache Parquet

MATLAB Table or Timetable Variable Type	Apache Arrow Data Type	Apache Parquet Data Type		Notes
		Logical Type	Physical Type	
double	double	None	DOUBLE	<ul style="list-style-type: none"> • MATLAB converts NaN values to null values in the Parquet file.
single	float	None	FLOAT	
int8	int8	INT	INT32	--
		<ul style="list-style-type: none"> • bitWidth=8 • isSigned=true 		
uint8	uint8	INT	INT32	—
		<ul style="list-style-type: none"> • bitWidth=8 • isSigned=false 		

MATLAB Table or Timetable Variable Type	Apache Arrow Data Type	Apache Parquet Data Type		Notes
		Logical Type	Physical Type	
int16	int16	INT <ul style="list-style-type: none"> • bitWidth=16 • isSigned=true 	INT32	—
uint16	uint16	INT <ul style="list-style-type: none"> • bitWidth=16 • isSigned=false 	INT32	—
int32	int32	None	INT32	—
uint32	uint32	INT <ul style="list-style-type: none"> • bitWidth=32 • isSigned=false 	INT32	—
int64	int64	INT <ul style="list-style-type: none"> • bitWidth=64 • isSigned=true 	INT64	—
uint64	uint64	INT <ul style="list-style-type: none"> • bitWidth=64 • isSigned=false 	INT64	—
logical	boolean	None	BOOLEAN	—

Binary Data Types

Reading Binary Data Types from Apache Parquet to MATLAB

Apache Parquet Data Type		Apache Arrow Data Type	MATLAB Table or Timetable Variable Type	Notes
Logical Type	Physical Type			
String	BYTE_ARRAY	String	string	—

Apache Parquet Data Type		Apache Arrow Data Type	MATLAB Table or Timetable Variable Type	Notes
Logical Type	Physical Type			
String	BYTE_ARRAY	Dictionary <ul style="list-style-type: none"> • index_type=int32 • value_type=string • ordered based on metadata. 	categorical	<ul style="list-style-type: none"> • Only if the Parquet file contains the original Arrow schema, then Arrow reads the data as a dictionary.
None	FIXED_LEN_BYTE_ARRAY	FixedSizeBinary(byte_width)	cell of uint8 values	—
None	BYTE_ARRAY	Binary	cell of uint8 values	—

Writing Binary Data Types from MATLAB to Apache Parquet

MATLAB Table or Timetable Variable Type	Apache Arrow Data Type	Apache Parquet Data Type		Notes
		Logical Type	Physical Type	
string	LargeString	String	BYTE_ARRAY	<ul style="list-style-type: none"> • MATLAB converts string arrays to Arrow LargeString arrays. • Other Parquet readers (such as PyArrow) may import Parquet String columns as LargeString arrays based on the original Arrow table schema stored in Parquet files written by MATLAB. • string(missing) values are written as null values in the Parquet file.
char	LargeString	String	BYTE_ARRAY	
cellstr	LargeString	String	BYTE_ARRAY	

MATLAB Table or Timetable Variable Type	Apache Arrow Data Type	Apache Parquet Data Type		Notes
		Logical Type	Physical Type	
categorical	Dictionary <ul style="list-style-type: none"> • values=string • indices can be int8, int16, int32, or int64 • ordered=true/false can be true or false based on the MATLAB Ordinal property 	String	BYTE_ARRAY	—

Date and Time Data Types

Reading Date and Time Data Types from Apache Parquet to MATLAB

Apache Parquet Data Type		Apache Arrow Data Type	MATLAB Table or Timetable Variable Type	Notes
Logical Type	Physical Type			
DATE	INT32	date32	datetime	<ul style="list-style-type: none"> • The INT32 value represents the number of days since the Unix epoch (January 1, 1970). • null values are imported as NaT.

Apache Parquet Data Type		Apache Arrow Data Type	MATLAB Table or Timetable Variable Type	Notes
Logical Type	Physical Type			
Timestamp <ul style="list-style-type: none"> • isAdjustedTo UTC can be true or false. • TimeUnit = can be milliseconds, microseconds, or nanoseconds. 	INT64	timestamp <ul style="list-style-type: none"> • unit • tz=None 	datetime	<ul style="list-style-type: none"> • When the Parquet file contains the original Arrow table schema as metadata: <ul style="list-style-type: none"> • If the timestamp data has been adjusted to UTC, the timezone is determined by the original schema. • If no timezone is present in the original schema and isAdjustedToUTC is true, MATLAB sets the TimeZone property of the imported datetime array to UTC. • null Timestamp and Date values are imported as NaT values.
Time <ul style="list-style-type: none"> • isAdjustedTo UTC can be true or false • unit=milliseconds 	INT32	time32 [ms] <ul style="list-style-type: none"> • unit=ms 	duration	<ul style="list-style-type: none"> • null time32 values are read in MATLAB as NaN sec.

Apache Parquet Data Type		Apache Arrow Data Type	MATLAB Table or Timetable Variable Type	Notes
Logical Type	Physical Type			
Time <ul style="list-style-type: none"> • isAdjustedTo UTC=true/false • unit= <ul style="list-style-type: none"> • microseconds • nanoseconds 	INT64	time64 [us/ns] <ul style="list-style-type: none"> • Unit can be microseconds or nanoseconds. 	duration	<ul style="list-style-type: none"> • null time64 values are read in MATLAB as NaN sec.

Writing Date and Time Data Types from MATLAB to Apache Parquet

MATLAB Table or Timetable Variable Type	Apache Arrow Data Type	Apache Parquet Data Type		Notes
		Logical Type	Physical Type	
datetime <ul style="list-style-type: none"> • TimeZone is set to a nonempty value. 	timestamp <ul style="list-style-type: none"> • unit=microseconds • tz is set to the value of the TimeZone property of the input datetime. 	Timestamp <ul style="list-style-type: none"> • TimeUnit=microseconds • isAdjustedTo UTC=true 	INT64	<ul style="list-style-type: none"> • This type represents an instant in time. • MATLAB datetime precision is truncated to 1 microsecond. Display format settings are not saved. • Date represented is unzoned. • tz is based on the TimeZone property. • If the TimeZone property is '', isAdjustedTo UTC is set to false.

MATLAB Table or Timetable Variable Type	Apache Arrow Data Type	Apache Parquet Data Type		Notes
		Logical Type	Physical Type	
duration	time64 <ul style="list-style-type: none"> unit=microseconds 	Time <ul style="list-style-type: none"> unit=microseconds isAdjustedToUTC=true 	INT64	<ul style="list-style-type: none"> MATLAB datetime precision is truncated to 1 microsecond. Display format settings are not saved. NaN sec are written as null values in the Parquet file.

Nested Data

To write nested tables and nested timetables to Parquet files, use `parquetwrite`. To import nested structured Parquet file data, use `parquetread`.

Reading Nested Types from Apache Parquet to MATLAB

Apache Parquet Data Type		Apache Arrow Data Type	MATLAB Table or Timetable Variable Type	Notes
Logical Type	Physical Type			
LIST	Any	LIST	cell	<ul style="list-style-type: none"> MATLAB cells (excluding <code>cellstrs</code>) are converted to Arrow <code>LargeList</code> arrays. Other Parquet readers (such as <code>PyArrow</code>) may import Parquet LIST columns as <code>LargeList</code> arrays based on the original Arrow table schema.

Apache Parquet Data Type		Apache Arrow Data Type	MATLAB Table or Timetable Variable Type	Notes
Logical Type	Physical Type			
LIST with n-tuple organization	Any	LIST with n-tuple organization	nested table	<ul style="list-style-type: none"> • If the child of a LIST is an n-tuple, then the LIST is interpreted as a struct array. • For more information on the n-tuple organization, see Parquet Logical Type Definitions

Writing Nested Types from MATLAB to Parquet

MATLAB Table or Timetable Variable Type	Apache Arrow Data Type	Apache Parquet Data Type		Notes
		Logical Type	Physical Type	
cell	LargeList	LIST	Any	<ul style="list-style-type: none"> • MATLAB cells (excluding cellstrs) are converted to Arrow LargeList arrays. • Other Parquet readers (such as PyArrow) may import Parquet LIST columns as LargeList arrays based on the original Arrow table schema.

MATLAB Table or Timetable Variable Type	Apache Arrow Data Type	Apache Parquet Data Type		Notes
		Logical Type	Physical Type	
nested table	Struct	NONE	Any	<ul style="list-style-type: none"> • Arrow writes Struct arrays as Parquet group-annotated columns. • If they exist, MATLAB table RowNames are added as a field to the exported Arrow Struct.
nested timetable	Struct	NONE	Any	<ul style="list-style-type: none"> • MATLAB table RowTimes are added to the exported Arrow Struct array.

See Also

parquetread | parquetwrite | write

Tall Arrays for Out-of-Memory Data

Tall arrays are used to work with out-of-memory data that is backed by a `datastore`. Datastores enable you to work with large data sets in small blocks that individually fit in memory, instead of loading the entire data set into memory at once. Tall arrays extend this capability to enable you to work with out-of-memory data using common functions.

What is a Tall Array?

Since the data is not loaded into memory all at once, tall arrays can be arbitrarily large in the first dimension (that is, they can have any number of rows). Instead of writing special code that takes into account the huge size of the data, such as with techniques like MapReduce, tall arrays let you work with large data sets in an intuitive manner that is similar to the way you would work with in-memory MATLAB arrays. Many core operators and functions work the same with tall arrays as they do with in-memory arrays. MATLAB works with small blocks of the data at a time, handling all of the data chunking and processing in the background, so that common expressions, such as `A+B`, work with big data sets.

Benefits of Tall Arrays

Unlike in-memory arrays, tall arrays typically remain unevaluated until you request that the calculations be performed using the `gather` function. This *deferred evaluation* allows you to work quickly with large data sets. When you eventually request output using `gather`, MATLAB combines the queued calculations where possible and takes the minimum number of passes through the data. The number of passes through the data greatly affects execution time, so it is recommended that you request output only when necessary.

Note Since `gather` returns results as in-memory MATLAB arrays, standard memory considerations apply. MATLAB might run out of memory if the result returned by `gather` is too large.

Creating Tall Tables

Tall tables are like in-memory MATLAB tables, except that they can have any number of rows. To create a tall table from a large data set, you first need to create a datastore for the data. If the datastore `ds` contains tabular data, then `tall(ds)` returns a tall table or tall timetable containing the data. See “Datastore” for more information about creating datastores.

Create a spreadsheet datastore that points to a tabular file of airline flight data. For folders that contain a collection of files, you can specify the entire folder location, or use the wildcard character, `*.csv`, to include multiple files with the same file extension in the datastore. Clean the data by treating `'NA'` values as missing data so that `tabularTextDatastore` replaces them with `NaN` values. Also, set the format of a few text variables to `%s` so that `tabularTextDatastore` reads them as cell arrays of character vectors.

```
ds = tabularTextDatastore('airlinesmall.csv');
ds.TreatAsMissing = 'NA';
ds.SelectedFormats(strcmp(ds.SelectedVariableNames, 'TailNum')) = '%s';
ds.SelectedFormats(strcmp(ds.SelectedVariableNames, 'CancellationCode')) = '%s';
```

Create a tall table from the datastore. When you perform calculations on this tall table, the underlying datastore reads blocks of data and passes them to the tall table to process. Neither the datastore nor the tall table retain any of the underlying data.

```
tt = tall(ds)
```

```
tt =
```

```
M×29 tall table
```

Year	Month	DayofMonth	DayOfWeek	DepTime	CRSDepTime	ArrTime	CRSArrTime
1987	10	21	3	642	630	735	727
1987	10	26	1	1021	1020	1124	1116
1987	10	23	5	2055	2035	2218	2157
1987	10	23	5	1332	1320	1431	1418
1987	10	22	4	629	630	746	742
1987	10	28	3	1446	1343	1547	1448
1987	10	8	4	928	930	1052	1049
1987	10	10	6	859	900	1134	1123
:	:	:	:	:	:	:	:
:	:	:	:	:	:	:	:

The display indicates that the number of rows, *M*, is currently unknown. MATLAB displays some of the rows, and the vertical ellipses `:` indicate that more rows exist in the tall table that are not currently being displayed.

Creating Tall Timetables

If the data you are working with has a time associated with each row of data, then you can use a tall timetable to work on the data. For information on creating tall timetables, see [Extended Capabilities \(timetable\)](#).

In this case, the tall table `tt` has times associated with each row, but they are broken down into several table variables such as `Year`, `Month`, `DayofMonth`, and so on. Combine all of these pieces of datetime information into a single new tall datetime variable `Dates`, which is based on the departure times `DepTime`. Then, create a tall timetable using `Dates` as the row times. Since `Dates` is the only datetime variable in the table, the `table2timetable` function automatically uses it for the row times.

```
hrs = (tt.DepTime - mod(tt.DepTime,100))/100;
mins = mod(tt.DepTime,100);
tt.Dates = datetime(tt.Year, tt.Month, tt.DayofMonth, hrs, mins, 0);
tt(:,1:8) = [];
TT = table2timetable(tt)
```

```
TT =
```

```
M×21 tall timetable
```

Dates	UniqueCarrier	FlightNum	TailNum	ActualElapsedTime	CRSElap
21-Oct-1987 06:42:00	'PS'	1503	'NA'	53	57
26-Oct-1987 10:21:00	'PS'	1550	'NA'	63	56
23-Oct-1987 20:55:00	'PS'	1589	'NA'	83	82
23-Oct-1987 13:32:00	'PS'	1655	'NA'	59	58
22-Oct-1987 06:29:00	'PS'	1702	'NA'	77	72
28-Oct-1987 14:46:00	'PS'	1729	'NA'	61	65
08-Oct-1987 09:28:00	'PS'	1763	'NA'	84	79

```

10-Oct-1987 08:59:00 'PS' 1800 'NA' 155 143
: : : : :
: : : : :

```

Creating Tall Arrays

When you extract a variable from a tall table or tall timetable, the result is a tall array of the appropriate underlying data type. A tall array can be a numeric, logical, datetime, duration, calendar duration, categorical, string, or cell array. Also, you can convert an in-memory array *A* into a tall array with `tA = tall(A)`. The in-memory array *A* must have one of the supported data types.

Extract the arrival delay `ArrDelay` from the tall timetable `TT`. This creates a new tall array variable with underlying data type double.

```
a = TT.ArrDelay
```

```
a =
```

```
M×1 tall double column vector
```

```

8
8
21
13
4
59
3
11
:
:

```

The `classUnderlying` and `isaUnderlying` functions are useful to determine the underlying data type of a tall array.

Deferred Evaluation

One important aspect of tall arrays is that as you work with them, most operations are not performed immediately. These operations appear to execute quickly, because the actual computation is deferred until you specifically request that the calculations be performed. You can trigger evaluation of a tall array with either the `gather` function (to bring the result into memory) or the `write` function (to write the result to disk). This deferred evaluation is important because even a simple command like `size(X)` executed on a tall array with a billion rows is not a quick calculation.

As you work with tall arrays, MATLAB keeps track of all of the operations to be carried out. This information is then used to optimize the number of passes through the data that will be required when you request output with the `gather` function. Thus, it is normal to work with unevaluated tall arrays and request output only when you require it. For more information, see “Deferred Evaluation of Tall Arrays” on page 13-152.

Calculate the mean and standard deviation of the arrival delay. Use these values to construct the upper and lower thresholds for delays that are within one standard deviation of the mean. Notice that the result of each operation indicates that the array has not been calculated yet.

```
m = mean(a, 'omitnan')
```



```
m =
```

```
    tall double
```

```
    ?
```

Preview deferred. Learn more.

```
s = std(a, 'omitnan')
```

```
s =
```

```
    tall
```

```
    ?
```

Preview deferred. Learn more.

```
one_sigma_bounds = [m-s m m+s]
```

```
one_sigma_bounds =
```

```
    M×N×... tall array
```

```
    ?    ?    ?    ...
    ?    ?    ?    ...
    ?    ?    ?    ...
    :    :    :
    :    :    :
```

Preview deferred. Learn more.

Evaluation with gather

The benefit of delayed evaluation is that when the time comes for MATLAB to perform the calculations, it is often possible to combine the operations in such a way that the number of passes through the data is minimized. So even if you perform many operations, MATLAB only makes extra passes through the data when absolutely necessary.

The `gather` function forces evaluation of all queued operations and brings the resulting output into memory. For this reason, you can think of `gather` as a bridge between tall arrays and in-memory arrays. For example, you cannot control `if` or `while` loops using a tall logical array, but once the array is evaluated with `gather` it becomes an in-memory logical array that you can use in these contexts.

Since `gather` returns the entire result in MATLAB, you should make sure that the result will fit in memory.

Use `gather` to calculate `one_sigma_bounds` and bring the result into memory. In this case, `one_sigma_bounds` requires several operations to calculate, but MATLAB combines the operations into one pass through the data. Since the data in this example is small, `gather` executes quickly. However, the elimination of passes through the data becomes more valuable as the size of your data increases.

```
sig1 = gather(one_sigma_bounds)
```

```
Evaluating tall expression using the Local MATLAB Session:
```

```
- Pass 1 of 1: Completed in 1.5 sec
```

```
Evaluation completed in 1.8 sec
```

```
sig1 =
```

```
    -23.4572     7.1201    37.6975
```

You can specify multiple inputs and outputs to `gather` if you want to evaluate several tall arrays at once. This technique is faster than calling `gather` multiple times. For example, calculate the minimum and maximum arrival delay. Computed separately, each value requires a pass through the data to calculate for a total of two passes. However, computing both values simultaneously requires only one pass through the data.

```
[max_delay, min_delay] = gather(max(a),min(a))
```

```
Evaluating tall expression using the Local MATLAB Session:
```

```
- Pass 1 of 1: Completed in 1.1 sec
```

```
Evaluation completed in 1.1 sec
```

```
max_delay =
```

```
    1014
```

```
min_delay =
```

```
    -64
```

These results indicate that on average, most flights arrive about 7 minutes late. But it is within one standard deviation for a flight to be up to 37 minutes late or 23 minutes early. The quickest flight in the data set arrived about an hour early, and the latest flight was delayed by many hours.

Saving, Loading, and Checkpointing Tall Arrays

The `save` function saves the *state* of a tall array, but does not copy any of the data. The resulting `.mat` file is typically small. However, the original data files must be available in the same location in order to subsequently use `load`.

The `write` function makes a copy of the data and saves the copy as a collection of files, which can consume a large amount of disk space. `write` executes all pending operations on the tall array to calculate the values prior to writing. Once `write` copies the data, it is independent of the original raw data. Therefore, you can recreate the tall array from the written files even if the original raw data is no longer available.

You can recreate the tall array from the written files by creating a new datastore that points to the location where the files were written. This functionality enables you to create *checkpoints* or *snapshots* of tall array data. Creating a checkpoint is a good way to save the results of preprocessing your data, so that the data is in a form that is more efficient to load.

If you have a tall array `TA`, then you can write it to the folder `location` with the command:

```
write(location,TA);
```

Later, to reconstruct `TA` from the written files, use the commands:

```
ds = datastore(location);  
TA = tall(ds);
```

Additionally, you can use the `write` function to trigger evaluation of a tall array and write the results to disk. This use of `write` is similar to `gather`, however, `write` does not bring any results into memory.

Supporting Functions

Most core functions work the same way with tall arrays as they do with in-memory arrays. However, in some cases the way that a function works with tall arrays is special or has limitations. You can tell whether a function supports tall arrays, and if it has any limitations, by looking at the bottom of the reference page for the function in the **Extended Capabilities** section (for an example, see `filloutliers`).

For a filtered list of all MATLAB functions that support tall arrays, see [Function List \(Tall Arrays\)](#).

Tall arrays also are supported by several toolboxes, enabling you to do things like write machine learning algorithms, deploy standalone apps, and run calculations in parallel or on a cluster. For more information, see “Extend Tall Arrays with Other Products” on page 13-185.

See Also

[gather](#) | [tall](#) | [datastore](#) | [table](#) | [mapreducer](#)

More About

- “Index and View Tall Array Elements” on page 13-157
- “Visualization of Tall Arrays” on page 13-171

Deferred Evaluation of Tall Arrays

One of the differences between tall arrays and in-memory MATLAB arrays is that tall arrays typically remain *unevaluated* until you request that calculations be performed. (The exceptions to this rule include plotting functions like `plot` and `histogram` and some statistical fitting functions like `fitlm`, which automatically evaluate tall array inputs.) While a tall array is in an unevaluated state, MATLAB might not know its size, its data type, or the specific values it contains. However, you can still use unevaluated arrays in your calculations as if the values were known. This allows you to work quickly with large data sets instead of waiting for each command to execute. For this reason, it is recommended that you use `gather` only when you require output.

MATLAB keeps track of all the operations you perform on unevaluated tall arrays as you enter them. When you eventually call `gather` to evaluate the queued operations, MATLAB uses the history of unevaluated commands to optimize the calculation by minimizing the number of passes through the data. Used properly, this optimization can save huge amounts of execution time by eliminating unnecessary passes through large data sets.

Display of Unevaluated Tall Arrays

The display of unevaluated tall arrays varies depending on how much MATLAB knows about the array and its values. There are three pieces of information reflected in the display:

- **Array size** — Unknown dimension sizes are represented by the variables `M` or `N` in the display. If no dimension sizes are known, then the size appears as `MxNx`
- **Array data type** — If the array has an unknown underlying data type, then its type appears as `tall array`. If the type is known, it is listed as, for example, `tall double array`.
- **Array values** — If the array values are unknown, then they appear as `?`. Known values are displayed.

MATLAB might know all, some, or none of these pieces of information about a given tall array, depending on the nature of the calculation.

For example, if the array has a known data type but unknown size and values, then the unevaluated tall array might look like this:

```
MxNx... tall double array
```

```
?   ?   ?   ...
?   ?   ?   ...
?   ?   ?   ...
:   :   :
:   :   :
```

If the type and relative size are known, then the display could be:

```
1xN tall char array
```

```
?   ?   ?   ...
```

If some of the data is known, then MATLAB displays the known values:

```
100x3 tall double matrix
```

```

0.8147    0.1622    0.6443
0.9058    0.7943    0.3786
0.1270    0.3112    0.8116
0.9134    0.5285    0.5328
0.6324    0.1656    0.3507
0.0975    0.6020    0.9390
0.2785    0.2630    0.8759
0.5469    0.6541    0.5502
:         :         :
:         :         :

```

Evaluation with gather

The `gather` function is used to evaluate tall arrays. `gather` accepts tall arrays as inputs and returns in-memory arrays as outputs. For this reason, you can think of this function as a bridge between tall arrays and in-memory arrays. For example, you cannot control `if` or `while` loop statements using a tall logical array, but once the array is evaluated with `gather` it becomes an in-memory logical value that you can use in these contexts.

`gather` performs all queued operations on a tall array and returns the *entire* result in memory. Since `gather` returns results as in-memory MATLAB arrays, standard memory considerations apply. MATLAB might run out of memory if the result returned by `gather` is too large.

Most of the time you can use `gather` to see the entire result of a calculation, particularly if the calculation includes a reduction operation such as `sum` or `mean`. However, if the result is too large to fit in memory, then you can use `gather(head(X))` or `gather(tail(X))` to perform the calculation and look at only the first or last few rows of the result.

Resolve Errors with gather

If you enter an erroneous command and `gather` fails to evaluate a tall array variable, then you must delete the variable from your workspace and recreate the tall array using *only* valid commands. This is because MATLAB keeps track of all the operations you perform on unevaluated tall arrays as you enter them. The only way to make MATLAB “forget” about an erroneous statement is to reconstruct the tall array from scratch.

Example: Calculate Size of Tall Array

This example shows what an unevaluated tall array looks like, and how to evaluate the array.

Create a datastore for the data set `airlinesmall.csv`. Convert the datastore into a tall table and then calculate the size.

```

varnames = {'ArrDelay', 'DepDelay', 'Origin', 'Dest'};
ds = tabularTextDatastore('airlinesmall.csv', 'TreatAsMissing', 'NA', ...
    'SelectedVariableNames', varnames);
tt = tall(ds)

```

```
tt =
```

```
M×4 tall table
```

```

ArrDelay    DepDelay    Origin    Dest
-----

```

```

      8      12      'LAX'      'SJC'
      8       1      'SJC'      'BUR'
     21     20      'SAN'      'SMF'
     13     12      'BUR'      'SJC'
      4     -1      'SMF'      'LAX'
     59     63      'LAX'      'SJC'
      3     -2      'SAN'      'SFO'
     11     -1      'SEA'      'LAX'
      :       :       :       :
      :       :       :       :

```

```
s = size(tt)
```

```
s =
```

```
1x2 tall double row vector
```

```
? ?
```

Preview deferred. Learn more.

Calculating the size of a tall array returns a small answer (a 1-by-2 vector), but the display indicates that an entire pass through the data is still required to calculate the size of `tt`.

Use the `gather` function to fully evaluate the tall array and bring the results into memory. As the command executes, there is a dynamic progress display in the command window that is particularly helpful with long calculations.

Note Always ensure that the result returned by `gather` will be able to fit in memory. If you use `gather` directly on a tall array without reducing its size using a function such as `mean`, then MATLAB might run out of memory.

```
tableSize = gather(s)
```

```
Evaluating tall expression using the Local MATLAB Session:
```

```
- Pass 1 of 1: Completed in 0.42 sec
```

```
Evaluation completed in 0.48 sec
```

```
tableSize =
```

```
123523      4
```

Example: Multi-pass Calculations with Tall Arrays

This example shows how several calculations can be combined to minimize the total number of passes through the data.

Create a datastore for the data set `airlinesmall.csv`. Convert the datastore into a tall table.

```

varnames = {'ArrDelay', 'DepDelay', 'Origin', 'Dest'};
ds = tabularTextDatastore('airlinesmall.csv', 'TreatAsMissing', 'NA', ...
    'SelectedVariableNames', varnames);
tt = tall(ds)

```

```
tt =
```

M×4 tall table

ArrDelay	DepDelay	Origin	Dest
8	12	'LAX'	'SJC'
8	1	'SJC'	'BUR'
21	20	'SAN'	'SMF'
13	12	'BUR'	'SJC'
4	-1	'SMF'	'LAX'
59	63	'LAX'	'SJC'
3	-2	'SAN'	'SFO'
11	-1	'SEA'	'LAX'
:	:	:	:
:	:	:	:

Subtract the mean value of `DepDelay` from `ArrDelay` to create a new variable `AdjArrDelay`. Then calculate the mean value of `AdjArrDelay` and subtract this mean value from `AdjArrDelay`. If these calculations were all evaluated separately, then MATLAB would require four passes through the data.

```
AdjArrDelay = tt.ArrDelay - mean(tt.DepDelay, 'omitnan');
AdjArrDelay = AdjArrDelay - mean(AdjArrDelay, 'omitnan')
```

```
AdjArrDelay =
```

```
M×1 tall double column vector
```

```
?
?
?
:
:
```

Preview deferred. [Learn more.](#)

Evaluate `AdjArrDelay` and view the first few rows. Because some calculations can be combined, only three passes through the data are required.

```
gather(head(AdjArrDelay))
```

```
Evaluating tall expression using the Local MATLAB Session:
```

```
- Pass 1 of 3: Completed in 0.4 sec
- Pass 2 of 3: Completed in 0.39 sec
- Pass 3 of 3: Completed in 0.23 sec
Evaluation completed in 1.2 sec
```

```
ans =
```

```
0.8799
0.8799
13.8799
5.8799
-3.1201
51.8799
-4.1201
3.8799
```

Summary of Behavior and Recommendations

- 1 Tall arrays remain unevaluated until you request output using `gather`.
- 2 Use `gather` in most cases to evaluate tall array calculations. If you believe the result of the calculations might not fit in memory, then use `gather(head(X))` or `gather(tail(X))` instead.
- 3 Work primarily with unevaluated tall arrays and request output only when necessary. The more queued calculations there are that are unevaluated, the more optimization MATLAB can do to minimize the number of passes through the data.
- 4 If you enter an erroneous tall array command and `gather` fails to evaluate a tall array variable, then you must delete the variable from your workspace and recreate the tall array using *only* valid commands.

See Also

`gather` | `write`

More About

- “Tall Arrays for Out-of-Memory Data” on page 13-146

Index and View Tall Array Elements

Tall arrays are too large to fit in memory, so it is common to view subsets of the data rather than the entire array. This page shows techniques to extract and view portions of a tall array.

Extract Top Rows of Array

Use the `head` function to extract the first rows in a tall array. `head` does not force evaluation of the array, so you must use `gather` to view the result.

```
tt = tall(table(randn(1000,1), randn(1000,1), randn(1000,1)))
```

```
tt =
```

```
1,000×3 tall table
```

Var1	Var2	Var3
0.53767	0.6737	0.29617
1.8339	-0.66911	1.2008
-2.2588	-0.40032	1.0902
0.86217	-0.6718	-0.3587
0.31877	0.57563	-0.12993
-1.3077	-0.77809	0.73374
-0.43359	-1.0636	0.12033
0.34262	0.55298	1.1363
:	:	:
:	:	:

```
t_head = gather(head(tt))
```

```
t_head =
```

```
8×3 table
```

Var1	Var2	Var3
0.53767	0.6737	0.29617
1.8339	-0.66911	1.2008
-2.2588	-0.40032	1.0902
0.86217	-0.6718	-0.3587
0.31877	0.57563	-0.12993
-1.3077	-0.77809	0.73374
-0.43359	-1.0636	0.12033
0.34262	0.55298	1.1363

Extract Bottom Rows of Array

Similarly, you can use the `tail` function to extract the bottom rows in a tall array.

```
t_tail = gather(tail(tt))
```

```
t_tail =
```

8×3 table

Var1	Var2	Var3
0.64776	0.47349	-0.27077
-0.31763	1.3656	0.43966
1.769	-1.6378	-0.50614
1.5106	2.0237	-0.18435
0.16401	0.77779	0.402
-0.28276	-0.5489	0.53923
1.1522	-0.12601	-0.73359
-1.1465	0.29958	-0.26837

Indexing Tall Arrays

All tall arrays support parentheses indexing. When you index a tall array using parentheses, such as `T(A)` or `T(A,B)`, the result is a new tall array containing only the specified rows and columns (or variables).

Like most other operations on tall arrays, indexing expressions are not evaluated immediately. You must use `gather` to evaluate the indexing operation. For more information, see “Deferred Evaluation of Tall Arrays” on page 13-152.

You can perform these types of indexing in the first dimension of a tall array:

- `B = A(:,...)`, where `:` selects all rows in `A`.
- `B = A(idx,...)`, where `idx` is a tall numeric column vector or non-tall numeric vector.
- `B = A(L,...)`, where `L` is a tall or non-tall logical array of the same height as `A`. For example, you can use relational operators, such as `tt(tt.Var1 < 10, :)`. When you index a tall array with a tall logical array, there are a few requirements. Each of the tall arrays:
 - Must be the same size in the first dimension.
 - Must be derived from a single tall array.
 - Must not have been indexed differently in the first dimension.
- `B = A(P:D:Q,...)` or `B = A(P:Q,...)`, where `P:D:Q` and `P:Q` are valid colon indexing expressions.
 - `head(tt,k)` provides a shortcut for `tt(1:k,:)`.
 - `tail(tt,k)` provides a shortcut for `tt(end-k:end,:)`.

Additionally, the number of subscripts you must specify depends on how many dimensions the array has:

- For tall column vectors, you can specify a single subscript such as `t(1:10)`.
- For tall row vectors, tall tables, and tall timetables, you must specify two subscripts.
- For tall arrays with two or more dimensions, you must specify two or more subscripts. For example, if the array has three dimensions, you can use an expression such as `tA(1:10, :, :)` or `tA(1:10, :)`, but not linear indexing expressions such as `tA(1:10)` or `tA(:)`.

Tip The `find` function locates nonzero elements in tall column vectors, and can be useful to generate a vector of indices for elements that meet particular conditions. For example, `k = find(X<0)` returns the linear indices for all negative elements in `X`.

For example, use parentheses indexing to retrieve the first ten rows of `tt`.

```
tt(1:10,:)
```

```
ans =
```

```
10x3 tall table
```

Var1	Var2	Var3
0.53767	0.6737	0.29617
1.8339	-0.66911	1.2008
-2.2588	-0.40032	1.0902
0.86217	-0.6718	-0.3587
0.31877	0.57563	-0.12993
-1.3077	-0.77809	0.73374
-0.43359	-1.0636	0.12033
0.34262	0.55298	1.1363
:	:	:
:	:	:

Retrieve the last 5 values of the table variable `Var1`.

```
tt(end-5:end, 'Var1')
```

```
ans =
```

```
6x1 tall table
```

Var1
1.769
1.5106
0.16401
-0.28276
1.1522
-1.1465

Retrieve every 100th row from the tall table.

```
tt(1:100:end,:)
```

```
ans =
```

```
10x3 tall table
```

Var1	Var2	Var3
0.53767	0.6737	0.29617
0.84038	-0.041663	-0.52093
0.18323	1.3419	0.052993

```
0.079934    -0.40492    -1.6163
0.26965     -1.5144     0.98399
-0.079893   -1.6848    -0.91182
0.47586     -2.1746     1.1754
1.9085      -0.79383    0.18343
:           :           :
:           :           :
```

Extract Tall Table Variables

The variables in a tall table or tall timetable are each tall arrays of different underlying data types. Standard indexing methods of tables and timetables also apply to tall tables and tall timetables, including the use of `timerange`, `withtol`, and `vartype`.

For example, index a tall table using dot notation `T.VariableName` to retrieve a single variable of data as a tall array.

```
tt.Var1
```

```
ans =
```

```
1,000×1 tall double column vector
```

```
0.5377
1.8339
-2.2588
0.8622
0.3188
-1.3077
-0.4336
0.3426
:
:
```

Use tab completion to look up the variables in a table if you cannot remember a precise variable name. For example, type `tt.` and then press **Tab**. A menu pops up:

```
ans =
    1,000x2 tall double matrix
    0.5377    0.6737
    1.8339   -0.6691
   -2.2588   -0.4003
    0.8622   -0.6718
    0.3188    0.5756
   -1.3077   -0.7781
   -0.4336   -1.0636
    0.3426    0.5530
     :
     :
```

To combine tall arrays with different underlying datastores, it is recommended that you use `write` to write the arrays (or calculation results) to disk, and then create a single new datastore referencing those locations:

```
files = {'folder/path/to/file1', 'folder/path/to/file2'};
ds = datastore(files);
```

Assignment and Deletion with Tall Arrays

The same subscripting rules apply whether you use indexing to assign or delete elements from a tall array. Deletion is accomplished by assigning one or more elements to the empty matrix, `[]`.

“()” Assignment

You can assign elements into a tall array using the general syntax `A(m, n, ...) = B`. The tall array `A` must exist and have a nonempty second dimension. The first subscript `m` must be either a colon `:` or a tall logical vector. With this syntax, `B` can be:

- Scalar
- A tall array derived from `A(m, ...)` where `m` is the same subscript as above. For example, `A(m, 1:10)`.
- An empty matrix, `[]` (for deletion)

“.” Assignment

For table indexing using the syntax `A.Var1 = B`, the array `B` must be a tall array with the appropriate number of rows. Typically, `B` is derived from existing data in the tall table. `Var1` can be either a new or existing variable in the tall table.

You cannot assign tall arrays as variables in a regular table, even if the table is empty.

Extract Specified Number of Rows in Sorted Order

Sorting all of the data in a tall array can be an expensive calculation. Most often, only a subset of rows at the beginning or end of a tall array is required to answer questions like “What is the first row in this data by year?”

The `topkrows` function returns a specified number of rows in sorted order for this purpose. For example, use `topkrows` to extract the top 12 rows sorted in descending order by the second column.

```
t_top12 = gather(topkrows(tt,12,2))
```

```
Evaluating tall expression using the Local MATLAB Session:
Evaluation completed in 0.067 sec
```

```
t_top12 =
```

```
12x3 table
```

Var1	Var2	Var3
-1.0322	3.5699	-1.4689
1.3312	3.4075	0.17694
-0.27097	3.1585	0.50127
0.55095	2.9745	1.382
0.45168	2.9491	-0.8215
-1.7115	2.7526	-0.3384
-0.21317	2.7485	1.9033
-0.43021	2.7335	0.77616
-0.59003	2.7304	0.67702
0.47163	2.7292	0.92099
-0.47615	2.683	-0.26113
0.72689	2.5383	-0.57588

Summarize Tall Array Contents

The `summary` function returns useful information about each variable in a tall table or timetable, such as the minimum and maximum values of numeric variables, and the number of occurrences of each category for categorical variables.

For example, create a tall table for the `outages.csv` data set and display the summary information. This data set contains numeric, datetime, and categorical variables.

```
fmts = {'%C' '%D' '%f' '%f' '%D' '%C'};
ds = tabularTextDatastore('outages.csv', 'TextscanFormats', fmts);
T = tall(ds);
summary(T)
```

```
Evaluating tall expression using the Local MATLAB Session:
```

```
- Pass 1 of 2: Completed in 0.16 sec
```

```
- Pass 2 of 2: Completed in 0.19 sec
```

```
Evaluation completed in 0.46 sec
```

```
Variables:
```

```
Region: 1,468x1 categorical
Values:
```

MidWest	142
NorthEast	557
SouthEast	389
SouthWest	26
West	354

```
OutageTime: 1,468x1 datetime
Values:
```

```
Min    2002-02-01 12:18
Max    2014-01-15 02:41
```

```
Loss: 1,468x1 double
Values:
```

```
Min    0
Max    23418
NumMissing 604
```

```
Customers: 1,468x1 double
Values:
```

```
Min    0
Max    5.9689e+06
NumMissing 328
```

```
RestorationTime: 1,468x1 datetime
Values:
```

```
Min    2002-02-07 16:50
Max    2042-09-18 23:31
NumMissing 29
```

```
Cause: 1,468x1 categorical
Values:
```

```
attack          294
earthquake      2
energy emergency 188
equipment fault 156
fire            25
severe storm   338
thunder storm  201
unknown        24
wind           95
winter storm   145
```

Return Subset of Calculation Results

Many of the examples on this page use `gather` to evaluate expressions and bring the results into memory. However, in these examples it is also trivial that the results fit in memory, since only a few rows are indexed at a time.

In cases where you are unsure if the result of an expression will fit in memory, it is recommended that you use `gather(head(X))` or `gather(tail(X))`. These commands still evaluate all of the queued calculations, but return only a small amount of the result that is guaranteed to fit in memory.

If you are certain that the result of a calculation will not fit in memory, use `write` to evaluate the tall array and write the results to disk instead.

See Also

`tall` | `table` | `topkrows` | `head` | `tail` | `gather`

More About

- “Tall Arrays for Out-of-Memory Data” on page 13-146

Histograms of Tall Arrays

This example shows how to use `histogram` and `histogram2` to analyze and visualize data contained in a tall array.

Create Tall Table

Create a datastore using the `airlinesmall.csv` data set. Treat 'NA' values as missing data so that they are replaced with NaN values. Select a subset of the variables to work with. Convert the datastore into a tall table.

```
varnames = {'ArrDelay', 'DepDelay', 'Year', 'Month'};
ds = tabularTextDatastore('airlinesmall.csv', 'TreatAsMissing', 'NA', ...
    'SelectedVariableNames', varnames);
T = tall(ds)
```

T =

Mx4 tall table

ArrDelay	DepDelay	Year	Month
8	12	1987	10
8	1	1987	10
21	20	1987	10
13	12	1987	10
4	-1	1987	10
59	63	1987	10
3	-2	1987	10
11	-1	1987	10
:	:	:	:
:	:	:	:

Plot Histogram of Arrival Delays

Plot a histogram of the `ArrDelay` variable to examine the frequency distribution of arrival delays.

```
h = histogram(T.ArrDelay);
```

Evaluating tall expression using the Local MATLAB Session:

```
- Pass 1 of 2: Completed in 1.6 sec
- Pass 2 of 2: Completed in 0.82 sec
```

Evaluation completed in 3.3 sec

```
title('Flight arrival delays, 1987 - 2008')
xlabel('Arrival Delay (minutes)')
ylabel('Frequency')
```

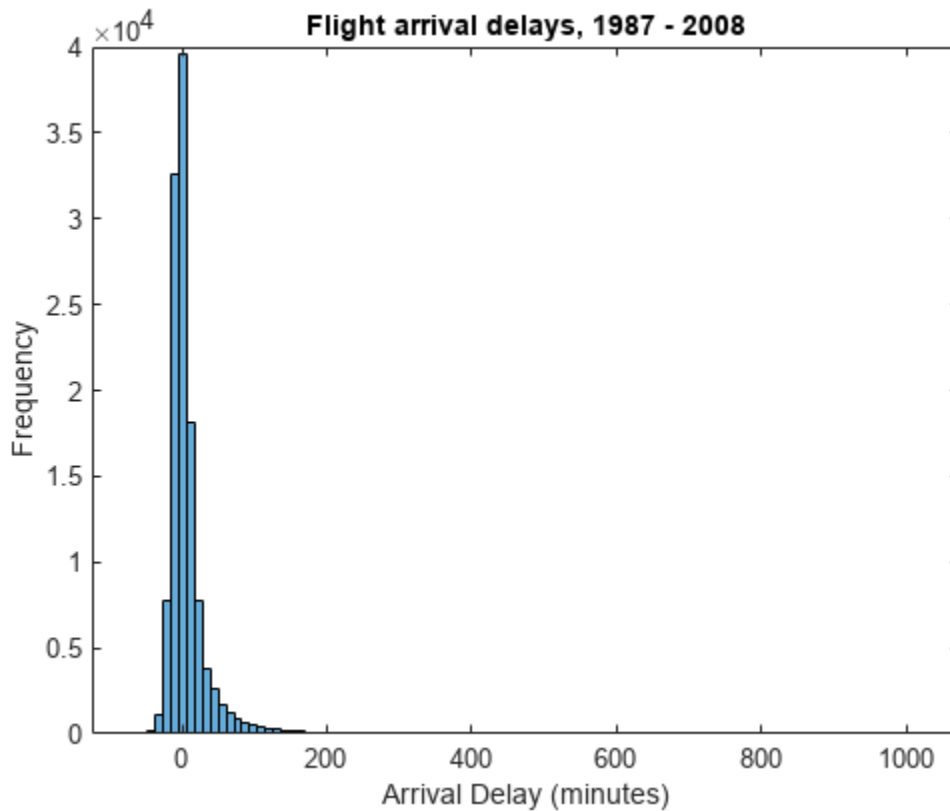

The arrival delay is most frequently a small number near 0, so these values dominate the plot and make it difficult to see other details.

Adjust Bin Limits of Histogram

Restrict the histogram bin limits to plot only arrival delays between -50 and 150 minutes. After you create a histogram object from a tall array, you cannot change any properties that would require recomputing the bins, including `BinWidth` and `BinLimits`. Also, you cannot use `morebins` or `fewerbins` to adjust the number of bins. In these cases, use `histogram` to reconstruct the histogram from the raw data in the tall array.

```
figure
histogram(T.ArrDelay, 'BinLimits', [-50,150])
```

```
Evaluating tall expression using the Local MATLAB Session:
- Pass 1 of 2: Completed in 1.3 sec
- Pass 2 of 2: Completed in 0.83 sec
Evaluation completed in 2.7 sec
```

```
title('Flight arrival delays between -50 and 150 minutes, 1987 - 2008')
xlabel('Arrival Delay (minutes)')
ylabel('Frequency')
```

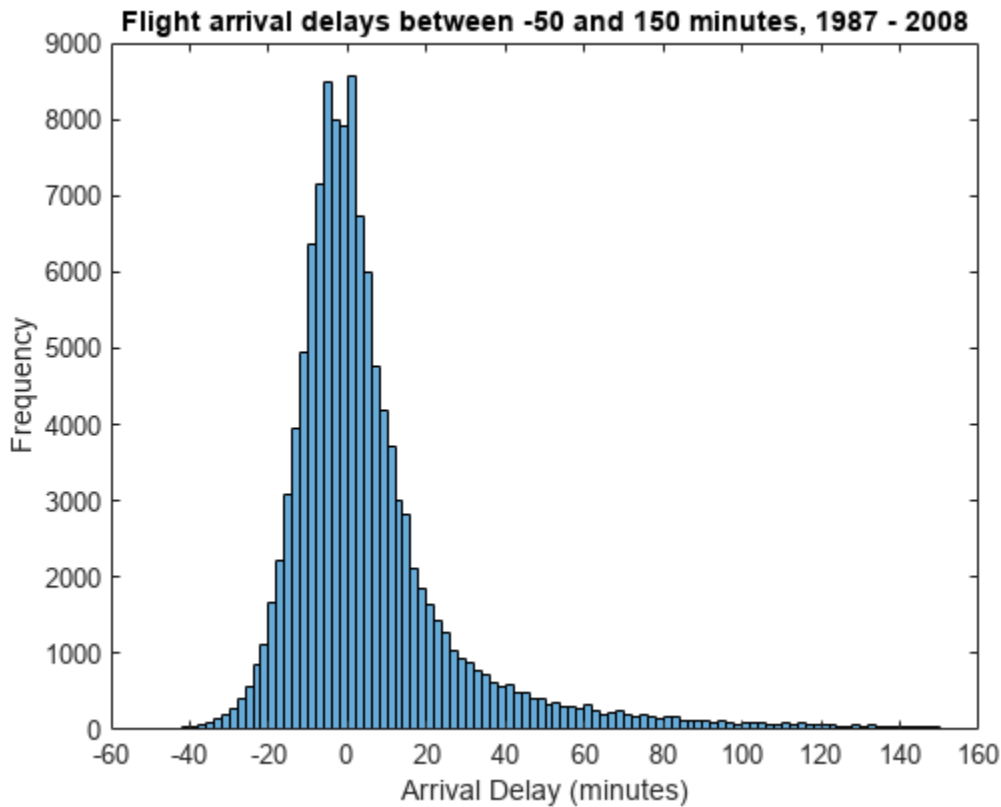

From this plot, it appears that long delays might be more common than initially expected. To investigate further, find the probability of an arrival delay that is one hour or greater.

Probability of Delays One Hour or Greater

The original histogram returned an object `h` that contains the bin values in the `Values` property and the bin edges in the `BinEdges` property. You can use these properties to perform in-memory calculations.

Determine which bins contain arrival delays of one hour (60 minutes) or more. Remove the last bin edge from the logical index vector so that it is the same length as the vector of bin values.

```
idx = h.BinEdges >= 60;
idx(end) = [];
```

Use `idx` to retrieve the value associated with each selected bin. Add the bin values together, divide by the total number of samples, and multiply by 100 to determine the overall probability of a delay greater than or equal to one hour. Since the total number of samples is computed from the original data set, use `gather` to explicitly evaluate the calculation and return an in-memory scalar.

```
N = numel(T.ArrDelay);
P = gather(sum(h.Values(idx))*100/N)
```

```
P = 4.4809
```

Overall, the odds of an arrival delay one hour or longer are about 4.5%.

Plot Bivariate Histogram of Delays by Month

Plot a bivariate histogram of the arrival delays that are 60 minutes or longer by month. This plot examines how seasonality affects arrival delay.

```
figure
h2 = histogram2(T.Month,T.ArrDelay,[12 50],'YBinLimits',[60 1100],...
    'Normalization','probability','FaceColor','flat');
```

Evaluating tall expression using the Local MATLAB Session:

- Pass 1 of 1: Completed in 1.5 sec

Evaluation completed in 1.7 sec

Evaluating tall expression using the Local MATLAB Session:

- Pass 1 of 1: Completed in 1.2 sec

Evaluation completed in 1.3 sec

```
title('Probability of arrival delays 1 hour or greater (by month)')
xlabel('Month (1-12)')
ylabel('Arrival Delay (minutes)')
zlabel('Probability')
xticks(1:12)
view(-126,23)
```

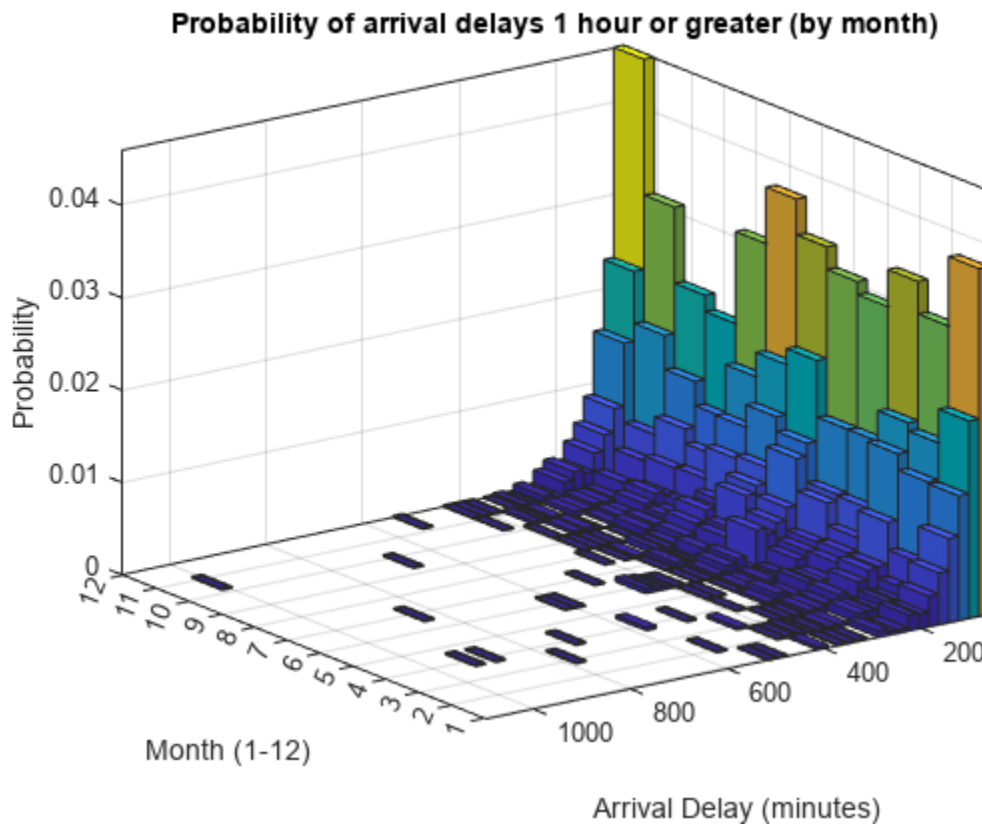

Delay Statistics by Month

Use the bivariate histogram object to calculate the probability of having an arrival delay one hour or greater in each month, and the mean arrival delay for each month. Put the results in a table with the

variable `P` containing the probability information and the variable `MeanByMonth` containing the mean arrival delay.

```
monthNames = {'Jan','Feb','Mar','Apr','May','Jun',...
              'Jul','Aug','Sep','Oct','Nov','Dec'};
G = findgroups(T.Month);
M = splitapply(@(x) mean(x,'omitnan'),T.ArrDelay,G);
delayByMonth = table(monthNames, sum(h2.Values,2)*100, gather(M), ...
                    'VariableNames',{'Month','P','MeanByMonth'})
```

Evaluating tall expression using the Local MATLAB Session:

- Pass 1 of 2: Completed in 0.77 sec

- Pass 2 of 2: Completed in 1.4 sec

Evaluation completed in 2.8 sec

delayByMonth=12×3 table

Month	P	MeanByMonth
{'Jan'}	9.6497	8.5954
{'Feb'}	7.7058	7.3275
{'Mar'}	9.0543	7.5536
{'Apr'}	7.2504	6.0081
{'May'}	7.4256	5.2949
{'Jun'}	10.35	10.264
{'Jul'}	10.228	8.7797
{'Aug'}	8.5989	7.4522
{'Sep'}	5.4116	3.6308
{'Oct'}	6.042	4.6059
{'Nov'}	6.9002	5.2835
{'Dec'}	11.384	10.571

The results indicate that flights in the holiday month of December have an 11.4% chance of being delayed longer than an hour, but are delayed by 10.5 minutes on average. This is closely followed by the summer months of June and July, where there is about a 10% chance of being delayed an hour or more and the average delay is roughly 9 or 10 minutes.

See Also

[histogram](#) | [histogram2](#) | [tall](#)

More About

- “Tall Arrays for Out-of-Memory Data” on page 13-146

Visualization of Tall Arrays

Visualizing large data sets requires that the data is summarized, binned, or sampled in some way to reduce the number of points that are plotted on the screen. In some cases, functions such as `histogram` and `pie` bin the data to reduce the size, while other functions such as `plot` and `scatter` use a more complex approach that avoids plotting duplicate pixels on the screen. For problems where the pixel overlap is relevant to the analysis, the `binscatter` function also offers an efficient way to visualize density patterns.

Visualizing tall arrays does *not* require the use of `gather`. MATLAB immediately evaluates and displays visualizations of tall arrays. Currently, you can visualize tall arrays using the functions and methods in this table.

Function	Required Toolboxes	Notes
<code>plot</code>	—	These functions plot in iterations, progressively adding to the plot as more data is read. During the updates, a progress indicator shows the proportion of data that has been plotted. Zooming and panning is supported during the updating process, before the plot is complete. To stop the update process, press the pause button in the progress indicator.
<code>scatter</code>	—	
<code>binscatter</code>	—	
<code>histogram</code>	—	
<code>histogram2</code>	—	
<code>pie</code>	—	For visualizing categorical data only.
<code>binScatterPlot</code>	Statistics and Machine Learning Toolbox™	Figure contains a slider to control the brightness and color detail in the image. The slider adjusts the value of the Gamma image correction parameter.
<code>kdensity</code>	Statistics and Machine Learning Toolbox	Produces a probability density estimate for the data, evaluated at 100 points for univariate data, or 900 points for bivariate data.

Function	Required Toolboxes	Notes
<code>datasample</code>	Statistics and Machine Learning Toolbox	<code>datasample</code> enables you to extract a subsample of a tall array in a statistically sound way compared to simple indexing. If the subset of data is small enough to fit in memory, then you can use plotting and fitting functions on the subset that do not directly support tall arrays.

Tall Array Plotting Examples

This example shows several different ways you can visualize tall arrays.

Create a datastore for the `airlinesmall.csv` data set, which contains rows of airline flight data. Select a subset of the table variables to work with and remove rows that contain missing values.

```
ds = tabularTextDatastore('airlinesmall.csv','TreatAsMissing','NA');
ds.SelectedVariableNames = {'Year','Month','ArrDelay','DepDelay','Origin','Dest'};
T = tall(ds);
T = rmmissing(T)
```

T =

Mx6 tall table

Year	Month	ArrDelay	DepDelay	Origin	Dest
1987	10	8	12	{'LAX'}	{'SJC'}
1987	10	8	1	{'SJC'}	{'BUR'}
1987	10	21	20	{'SAN'}	{'SMF'}
1987	10	13	12	{'BUR'}	{'SJC'}
1987	10	4	-1	{'SMF'}	{'LAX'}
1987	10	59	63	{'LAX'}	{'SJC'}
1987	10	3	-2	{'SAN'}	{'SFO'}
1987	10	11	-1	{'SEA'}	{'LAX'}
:	:	:	:	:	:
:	:	:	:	:	:

Pie Chart of Flights by Month

Convert the numeric `Month` variable into a categorical variable that reflects the name of the month. Then plot a pie chart showing how many flights are in the data for each month of the year.

```
T.Month = categorical(T.Month,1:12,{'Jan','Feb','Mar','Apr','May','Jun','Jul','Aug','Sep','Oct',
```

T =

Mx6 tall table

Year	Month	ArrDelay	DepDelay	Origin	Dest
------	-------	----------	----------	--------	------

1987	Oct	8	12	{ 'LAX' }	{ 'SJC' }
1987	Oct	8	1	{ 'SJC' }	{ 'BUR' }
1987	Oct	21	20	{ 'SAN' }	{ 'SMF' }
1987	Oct	13	12	{ 'BUR' }	{ 'SJC' }
1987	Oct	4	-1	{ 'SMF' }	{ 'LAX' }
1987	Oct	59	63	{ 'LAX' }	{ 'SJC' }
1987	Oct	3	-2	{ 'SAN' }	{ 'SFO' }
1987	Oct	11	-1	{ 'SEA' }	{ 'LAX' }
:	:	:	:	:	:
:	:	:	:	:	:

```
pie(T.Month)
```

Evaluating tall expression using the Local MATLAB Session:

- Pass 1 of 2: Completed in 2.2 sec

- Pass 2 of 2: Completed in 1.7 sec

Evaluation completed in 5 sec

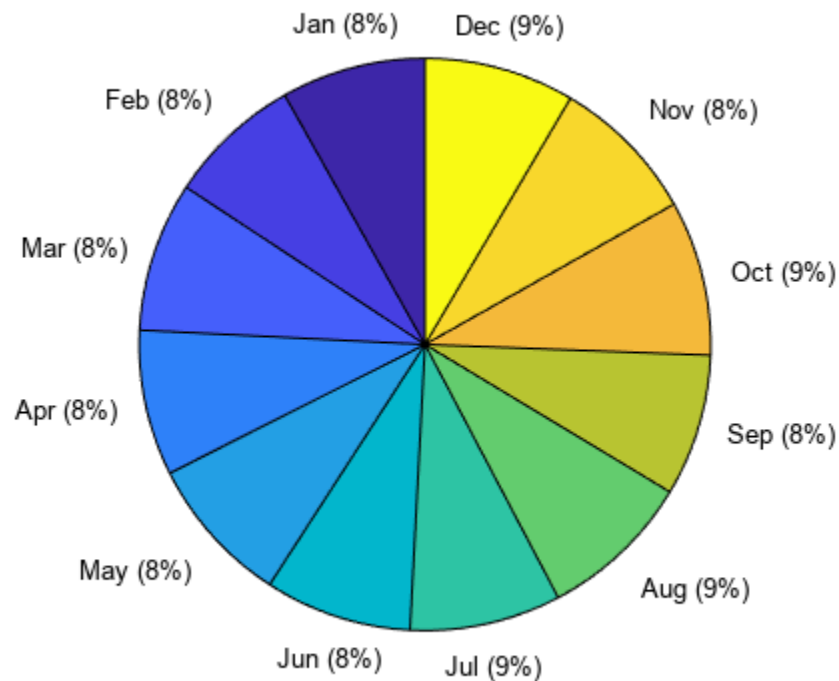

Histogram of Delays

Plot a histogram of the arrival delays for each flight in the data. Since the data has a long tail, limit the plotting area using the `BinLimits` name-value pair.

```
histogram(T.ArrDelay, 'BinLimits', [-50 150])
```

Evaluating tall expression using the Local MATLAB Session:

- Pass 1 of 2: Completed in 4.7 sec

- Pass 2 of 2: Completed in 1.5 sec
Evaluation completed in 7.4 sec

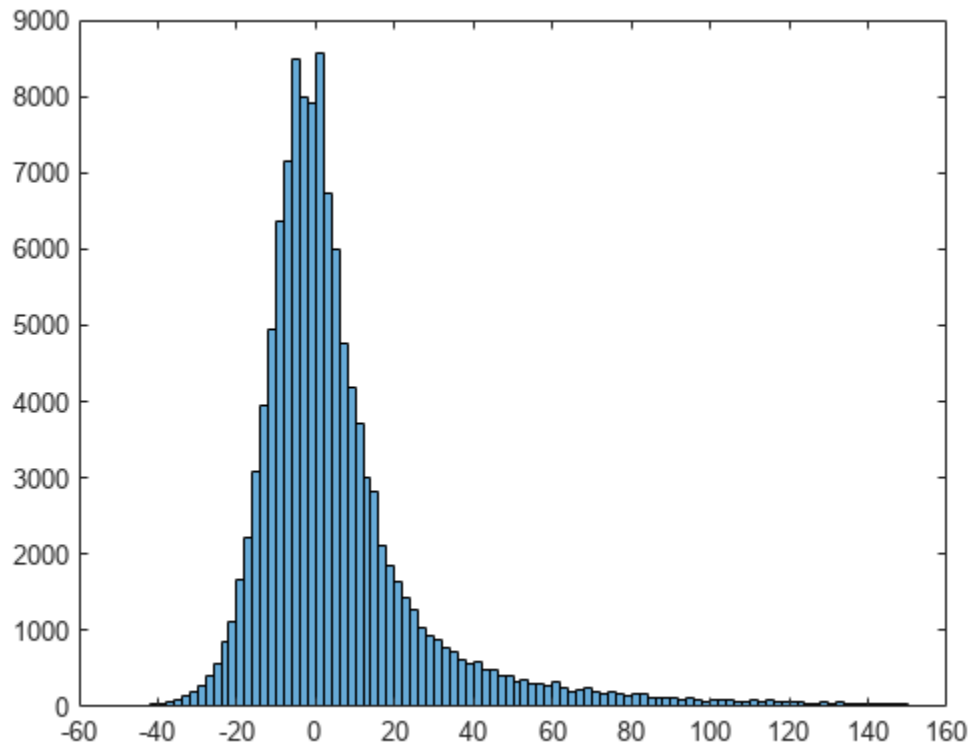

Scatter Plot of Delays

Plot a scatter plot of arrival and departure delays. You can expect a strong correlation between these variables since flights that leave late are also likely to arrive late.

When operating on tall arrays, the `plot`, `scatter`, and `binscatter` functions plot the data in iterations, progressively adding to the plot as more data is read. During the updates the top of the plot has a progress indicator showing how much data has been plotted. Zooming and panning is supported during the updates before the plot is complete.

```
scatter(T.ArrDelay,T.DepDelay)
xlabel('Arrival Delay')
ylabel('Departure Delay')
xlim([-140 1000])
ylim([-140 1000])
```

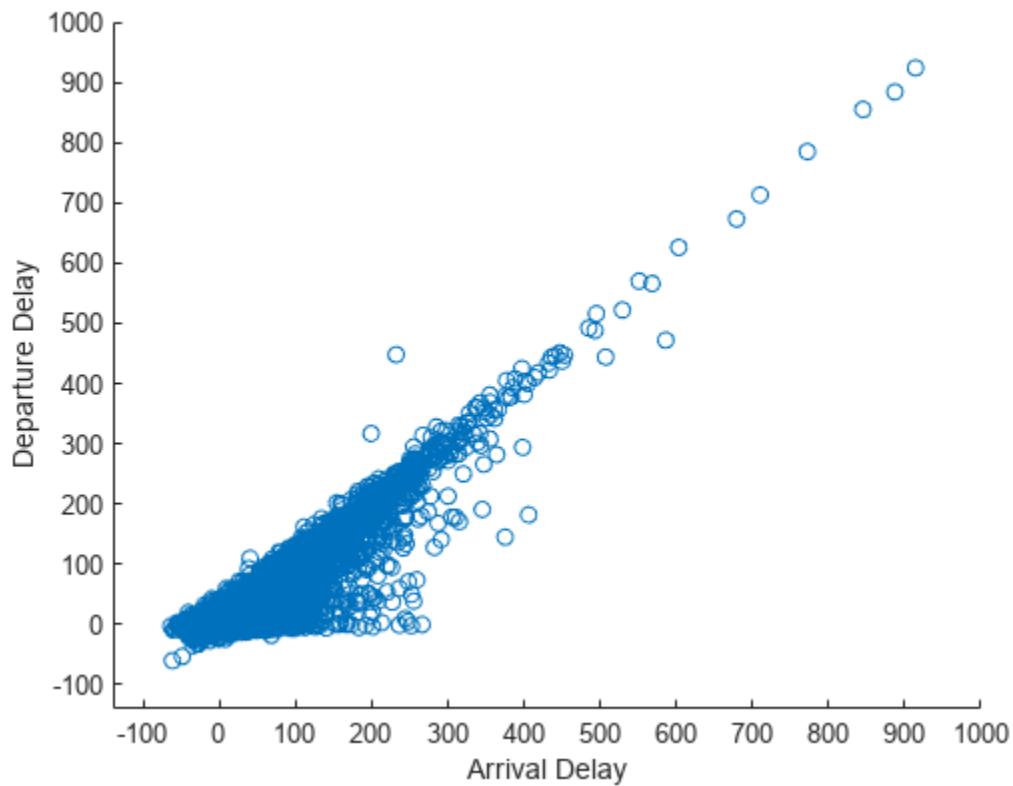

The progress bar also includes a **Pause/Resume** button. Use the button to stop the plot updates early once enough data is displayed.

Fit Trend Line

Use the `polyfit` and `polyval` functions to overlay a linear trend line on the plot of arrival and departure delays.

```
hold on
p = polyfit(T.ArrDelay,T.DepDelay,1);
x = sort(T.ArrDelay,1);
yp = polyval(p,x);
plot(x,yp,'r-')
hold off
```

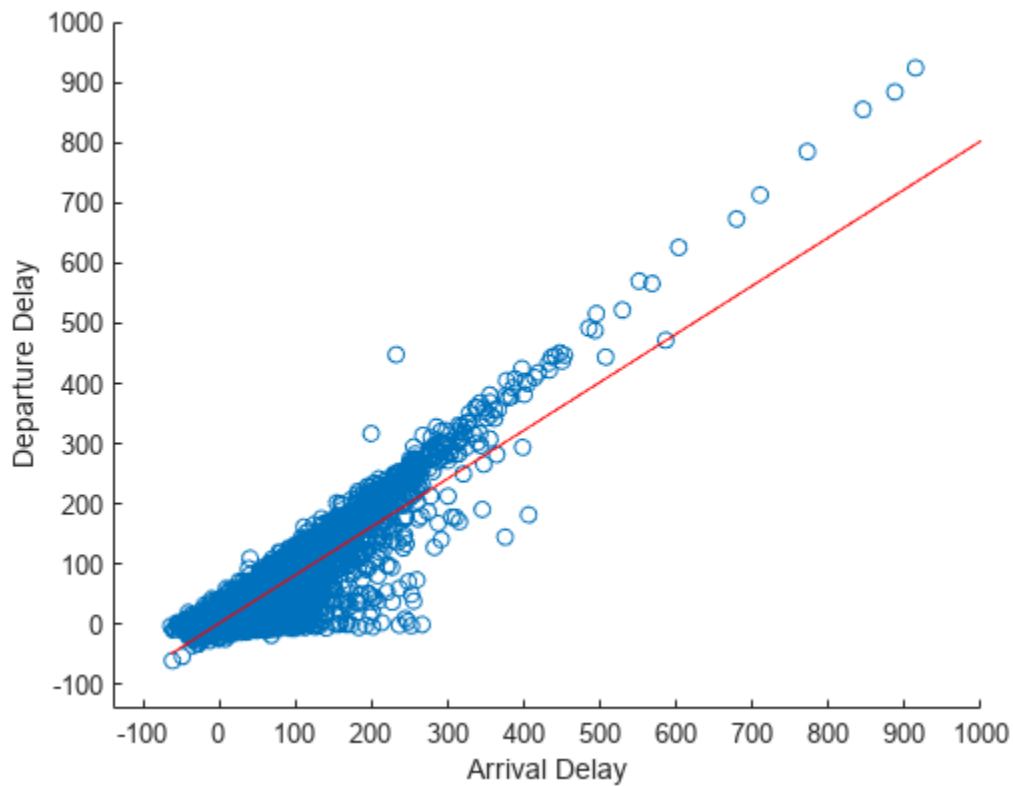

Visualize Density

The scatter plot of points is helpful up to a certain point, but it can be hard to decipher information from the plot if the points overlap extensively. In that case, it helps to visualize the density of points in the plot to spot trends.

Use the `binscatter` function to visualize the density of points in the plot of arrival and departure delays.

```
binscatter(T.ArrDelay,T.DepDelay,'XLimits',[-100 1000],'YLimits',[-100 1000])
xlim([-100 1000])
ylim([-100 1000])
xlabel('Arrival Delay')
ylabel('Departure Delay')
```

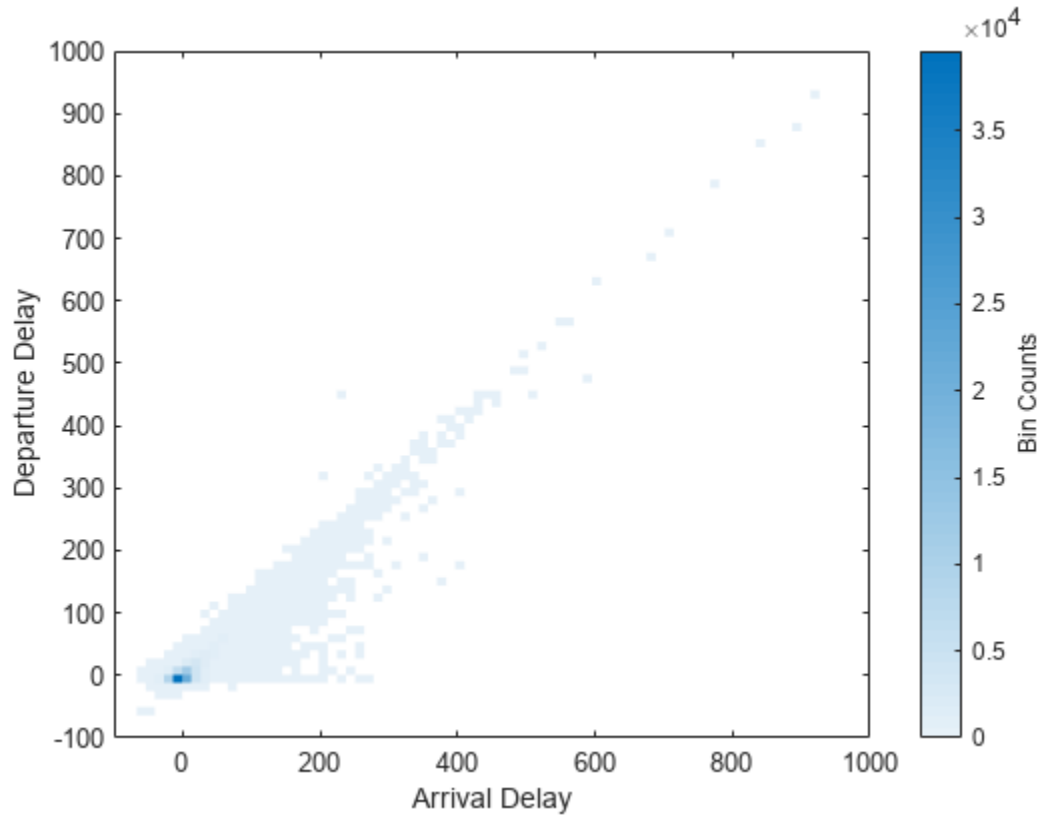

Adjust the CLim property of the axes so that all bin values greater than 150 are colored the same. This prevents a few bins with very large values from dominating the plot.

```
ax = gca;  
ax.CLim = [0 150];
```

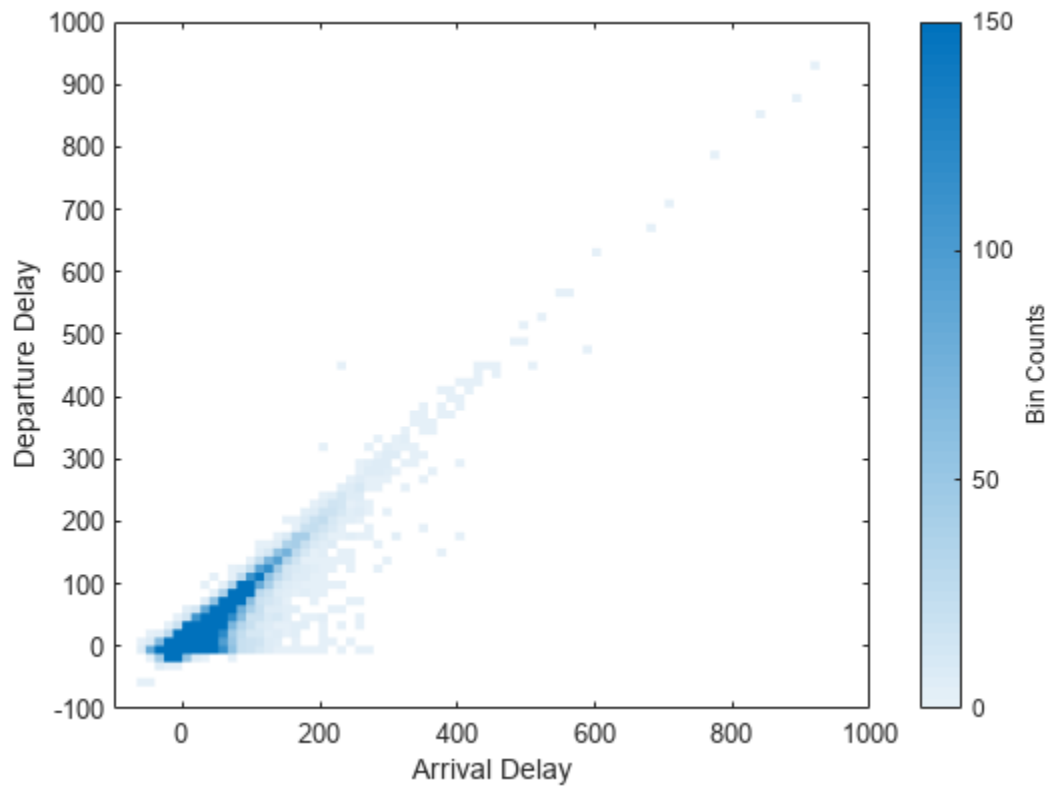

See Also

`tall` | `polyfit` | `plot`

More About

- “Tall Arrays for Out-of-Memory Data” on page 13-146

Grouped Statistics Calculations with Tall Arrays

This example shows how to calculate grouped statistics of a tall timetable containing power outage data. The example uses the `grouptransform`, `groupsummary`, and `groupcounts` functions to calculate various quantities of interest, such as the most common power outage cause in each region. Even though the raw data in this example only has about 1500 rows, you can use the techniques presented here on much larger data sets because no assumptions are made about the size of the data.

Create Datastore and Tall Timetable

The sample file, `outages.csv`, contains data representing electric utility outages in the United States. The file contains six columns: `Region`, `OutageTime`, `Loss`, `Customers`, `RestorationTime`, and `Cause`.

Create a datastore for the `outages.csv` file. Use the `"TextScanFormats"` option to specify the kind of data each column contains: categorical ("`%C`"), floating-point numeric ("`%f`"), or datetime ("`%D`").

```
data_formats = ["%C", "%D", "%f", "%f", "%D", "%C"];
ds = tabularTextDatastore("outages.csv", "TextscanFormats", data_formats);
```

Create a tall table on top of the datastore, and convert the tall table into a tall timetable. The `OutageTime` variable is used for the row times since it is the first datetime or duration variable in the table.

```
T = tall(ds);
T = table2timetable(T)
```

```
T =
```

```
Mx5 tall timetable
```

OutageTime	Region	Loss	Customers	RestorationTime	Cause
?	?	?	?	?	?
?	?	?	?	?	?
?	?	?	?	?	?
:	:	:	:	:	:
:	:	:	:	:	:

Replace Missing Data

Some of the rows in the `RestorationTime` variable have missing times, represented by `NaN` values. Remove these rows from the table.

```
T = rmmissing(T, "DataVariables", "RestorationTime");
```

For the numeric variables in the timetable, instead of removing rows with missing values, replace the missing values with the mean value for each region.

```
T = grouptransform(T, "Region", "meanfill", ["Loss", "Customers"]);
```

Use `ismissing` to confirm that no pieces of missing data remain in the table.

```
tf = any(ismissing(T),"all");
gather(tf)
```

Evaluating tall expression using the Local MATLAB Session:

```
- Pass 1 of 4: Completed in 0.47 sec
- Pass 2 of 4: Completed in 1.5 sec
- Pass 3 of 4: Completed in 0.86 sec
- Pass 4 of 4: Completed in 0.94 sec
Evaluation completed in 5.7 sec
```

```
ans = logical
      0
```

Preview Data

Now that the data does not contain missing values, bring a small number of rows into memory to get an idea of what the data contains.

```
gather(head(T))
```

Evaluating tall expression using the Local MATLAB Session:

```
- Pass 1 of 1: Completed in 0.64 sec
Evaluation completed in 0.85 sec
```

```
ans=8x5 timetable
```

OutageTime	Region	Loss	Customers	RestorationTime	Cause
2002-02-01 12:18	SouthWest	458.98	1.8202e+06	2002-02-07 16:50	winter storm
2003-02-07 21:15	SouthEast	289.4	1.4294e+05	2003-02-17 08:14	winter storm
2004-04-06 05:44	West	434.81	3.4037e+05	2004-04-06 06:10	equipment fault
2002-03-16 06:18	MidWest	186.44	2.1275e+05	2002-03-18 23:23	severe storm
2003-06-18 02:49	West	0	0	2003-06-18 10:54	attack
2004-06-20 14:39	West	231.29	1.5354e+05	2004-06-20 19:16	equipment fault
2002-06-06 19:28	West	311.86	1.5354e+05	2002-06-07 00:51	equipment fault
2003-07-16 16:23	NorthEast	239.93	49434	2003-07-17 01:12	fire

Mean Power Outage Duration by Region

Determine the mean power outage duration in each region using `groupsummary`. First, create a new variable `OutageDuration` in the table that contains the duration of each outage, found by subtracting the outage time from the restoration time. In the call to `groupsummary`, specify:

- "Region" as the grouping variable
- "mean" as the computation method
- "OutageDuration" as the variable to operate on.

```
T.OutageDuration = T.RestorationTime - T.OutageTime;
times = groupsummary(T,"Region","mean","OutageDuration")
```

```
times =
```

```
Mx3 tall table
```

Region	GroupCount	mean_OutageDuration
--------	------------	---------------------

```

?      ?      ?
?      ?      ?
?      ?      ?
:      :      :
:      :      :

```

Change the display format of the duration results to be in days, and gather the results into memory. The results show the mean outage duration in each region, as well as the number of reported outages in each region.

```

times.mean_OutageDuration.Format = "d";
times = gather(times)

```

```

Evaluating tall expression using the Local MATLAB Session:
- Pass 1 of 2: Completed in 1.8 sec
- Pass 2 of 2: Completed in 0.91 sec
Evaluation completed in 3.6 sec

```

```

times=5x3 table
  Region      GroupCount      mean_OutageDuration
  -----
  Midwest      138      34.135 days
  NorthEast    548      24.21 days
  SouthEast    379      1.7013 days
  SouthWest    25      2.4799 days
  West         349      28.061 days

```

Most Common Power Outage Causes by Region

Determine how often each power outage cause occurs in each region. Use `groupcounts` with the `Cause` and `Region` variables as grouping variables. Gather the results into memory.

```

causes = groupcounts(T, ["Cause", "Region"]);
causes = gather(causes)

```

```

Evaluating tall expression using the Local MATLAB Session:
- Pass 1 of 2: Completed in 0.53 sec
- Pass 2 of 2: Completed in 0.58 sec
Evaluation completed in 1.7 sec

```

```

causes=43x4 table
  Cause      Region      GroupCount      Percent
  -----
  attack      Midwest      12      0.83391
  attack      NorthEast    135      9.3815
  attack      SouthEast    19      1.3204
  attack      West         126      8.7561
  earthquake  NorthEast    1      0.069493
  earthquake  West         1      0.069493
  energy emergency Midwest      19      1.3204
  energy emergency NorthEast    29      2.0153
  energy emergency SouthEast    79      5.4899
  energy emergency SouthWest    7      0.48645
  energy emergency West         46      3.1967
  equipment fault Midwest      9      0.62543

```

```

equipment fault    NorthEast    17      1.1814
equipment fault    SouthEast    40      2.7797
equipment fault    SouthWest    2       0.13899
equipment fault    West        85      5.9069
:
```

Each cause occurs several times in the table, so even though the table contains the correct data it is not in the proper format to see how often each cause occurs in each region. To improve the presentation of the data, unstack the `GroupCount` variable so that each column corresponds to a region and each row corresponds to an outage cause.

```
RegionCauses = gather(unstack(causes, "GroupCount", "Region", "GroupingVariables", "Cause"))
```

RegionCauses=10×6 table

Cause	MidWest	NorthEast	SouthEast	SouthWest	West
attack	12	135	19	NaN	126
earthquake	NaN	1	NaN	NaN	1
energy emergency	19	29	79	7	46
equipment fault	9	17	40	2	85
fire	NaN	5	3	NaN	17
severe storm	30	139	132	6	22
thunder storm	31	102	54	6	7
unknown	4	10	3	NaN	4
wind	16	40	13	3	22
winter storm	17	70	36	1	19

Not all combinations of outage causes and regions are represented in the data, so the resulting table contains some NaNs. Fill in the NaN values with zeros.

```
RegionCauses = fillmissing(RegionCauses, "constant", {"", 0, 0, 0, 0, 0})
```

RegionCauses=10×6 table

Cause	MidWest	NorthEast	SouthEast	SouthWest	West
attack	12	135	19	0	126
earthquake	0	1	0	0	1
energy emergency	19	29	79	7	46
equipment fault	9	17	40	2	85
fire	0	5	3	0	17
severe storm	30	139	132	6	22
thunder storm	31	102	54	6	7
unknown	4	10	3	0	4
wind	16	40	13	3	22
winter storm	17	70	36	1	19

Worst Power Outages in Each Region

Calculate the broadest customer impact for each power outage in each region.

```
WorstOutages = groupsummary(T, ["Region", "Cause"], "max", "Customers");
WorstOutages = gather(WorstOutages)
```

Evaluating tall expression using the Local MATLAB Session:

- Pass 1 of 2: Completed in 0.36 sec

- Pass 2 of 2: Completed in 0.5 sec

Evaluation completed in 1.2 sec

WorstOutages=43x4 table

Region	Cause	GroupCount	max_Customers
MidWest	attack	12	2.4403e+05
MidWest	energy emergency	19	5.0376e+05
MidWest	equipment fault	9	2.4403e+05
MidWest	severe storm	30	3.972e+06
MidWest	thunder storm	31	3.8233e+05
MidWest	unknown	4	3.0879e+06
MidWest	wind	16	2.8666e+05
MidWest	winter storm	17	7.7697e+05
NorthEast	attack	135	1.5005e+05
NorthEast	earthquake	1	0
NorthEast	energy emergency	29	1.5005e+05
NorthEast	equipment fault	17	1.667e+05
NorthEast	fire	5	4.5139e+05
NorthEast	severe storm	139	1.0735e+06
NorthEast	thunder storm	102	5.9689e+06
NorthEast	unknown	10	2.4983e+06
:			

Combine the data in the Region and Cause variables into a single categorical variable by briefly converting them into strings. Then, create a categorical histogram of the maximum number of affected customers for each cause in each region.

```
WorstOutages.RegionCause = categorical(string(WorstOutages.Region)+" (" +string(WorstOutages.Cause)
histogram("Categories",WorstOutages.RegionCause,"BinCounts",WorstOutages.max_Customers,...
"DisplayOrder","descend")
ylabel("Max # Affected Customers")
```

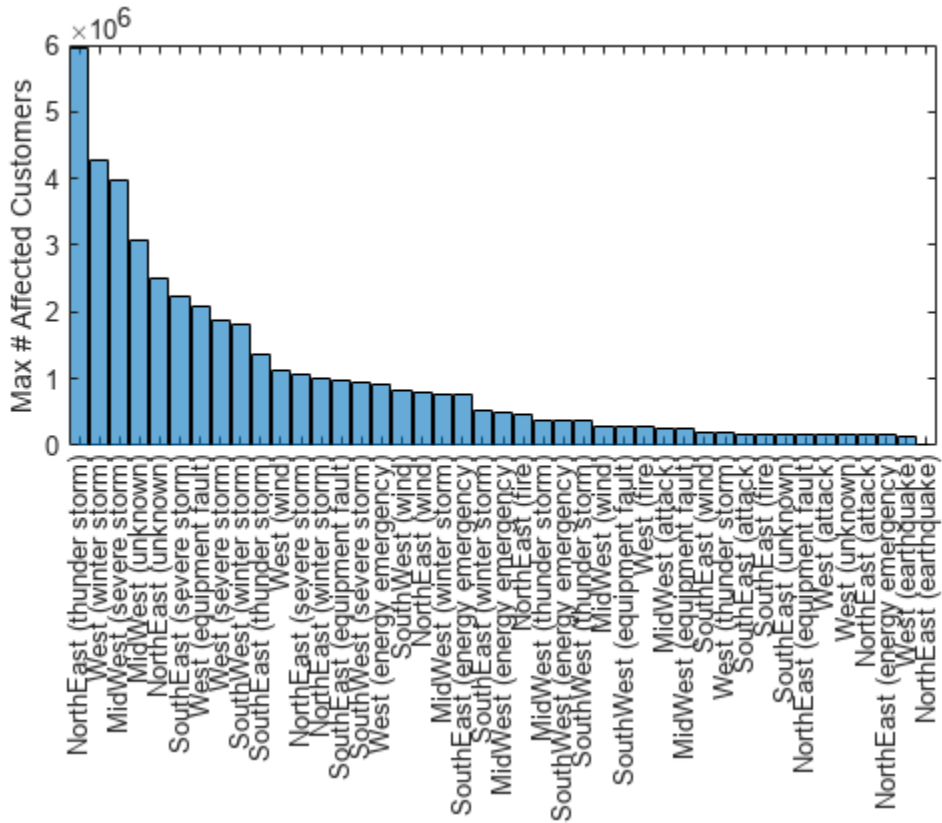

See Also

`findgroups | splitapply | tall`

More About

- “Grouping Variables To Split Data”
- “Split Data into Groups and Calculate Statistics”
- “Perform Calculations by Group in Table”

Extend Tall Arrays with Other Products

Products Used: Statistics and Machine Learning Toolbox, Database Toolbox, Parallel Computing Toolbox, MATLAB Parallel Server, MATLAB Compiler

Several toolboxes enhance the capabilities of tall arrays. These enhancements include writing machine learning algorithms, integrating with big data systems, and deploying standalone apps.

Statistics and Machine Learning

Statistics and Machine Learning Toolbox enables you to perform advanced statistical calculations on tall arrays. Capabilities include:

- K-means clustering
- Linear regression fitting
- Grouped statistics
- Classification

See “Analysis of Big Data with Tall Arrays” (Statistics and Machine Learning Toolbox) for more information.

Control Where Your Code Runs

When you execute calculations on tall arrays, the default execution environment uses either the local MATLAB session, or a local parallel pool if you have Parallel Computing Toolbox. Use the `mapreducer` function to change the execution environment of tall arrays when using Parallel Computing Toolbox, MATLAB Parallel Server, or MATLAB Compiler:

- Parallel Computing Toolbox — Run calculations in parallel using local or cluster workers to speed up large tall array calculations. See “Use Tall Arrays on a Parallel Pool” (Parallel Computing Toolbox) or “Process Big Data in the Cloud” (Parallel Computing Toolbox) for more information.
- MATLAB Parallel Server — Run tall array calculations on a cluster, including Apache Spark™ enabled Hadoop clusters. This can significantly reduce the execution time of very large calculations. See “Use Tall Arrays on a Spark Cluster” (Parallel Computing Toolbox) for more information.
- MATLAB Compiler — Deploy MATLAB applications containing tall arrays as standalone apps on Apache Spark. See “Spark Applications” (MATLAB Compiler) for more information.

One of the benefits of developing your algorithms with tall arrays is that you only need to write the code once. You can develop your code locally, then use `mapreducer` to scale up and take advantage of the capabilities offered by Parallel Computing Toolbox, MATLAB Parallel Server, or MATLAB Compiler, without needing to rewrite your algorithm.

Note Each tall array is bound to a single execution environment when it is constructed using `tall(ds)`. If that execution environment is later modified or deleted, then the tall array becomes invalid.

For this reason, each time you change the execution environment you must reconstruct the tall array.

Work with Databases

Database Toolbox enables you to create a tall table from a `DatabaseDatastore` that is backed by data in a database. For more information, see “Analyze Large Data in Database Using Tall Arrays” (Database Toolbox).

Note `DatabaseDatastore` has these limitations:

- `DatabaseDatastore` must use the local MATLAB session as the execution environment. Set this environment using the command `mapreducer(0)`.
 - Standalone applications containing tall arrays that use `DatabaseDatastore` cannot be deployed against Apache Spark using MATLAB Compiler.
-

See Also

`mapreducer` | `gcmr` | `tall`

More About

- “Tall Arrays for Out-of-Memory Data” on page 13-146

Analyze Big Data in MATLAB Using Tall Arrays

This example shows how to use tall arrays to work with big data in MATLAB®. You can use tall arrays to perform a variety of calculations on different types of data that does not fit in memory. These include basic calculations, as well as machine learning algorithms within Statistics and Machine Learning Toolbox™.

This example operates on a small subset of data on a single computer, and then it then scales up to analyze all of the data set. However, this analysis technique can scale up even further to work on data sets that are so large they cannot be read into memory, or to work on systems like Apache Spark™.

Introduction to Tall Arrays

Tall arrays and tall tables are used to work with out-of-memory data that has any number of rows. Instead of writing specialized code that takes into account the huge size of the data, tall arrays and tables let you work with large data sets in a manner similar to in-memory MATLAB® arrays. The difference is that tall arrays typically remain unevaluated until you request that the calculations be performed.

This deferred evaluation enables MATLAB to combine the queued calculations where possible and take the minimum number of passes through the data. Since the number of passes through the data greatly affects execution time, it is recommended that you request output only when necessary.

Create datastore for Collection of Files

Creating a datastore enables you to access a collection of data. A datastore can process arbitrarily large amounts of data, and the data can even be spread across multiple files in multiple folders. You can create a datastore for most types of files, including a collection of tabular text files (demonstrated here), spreadsheets, images, a SQL database (Database Toolbox™ required), Hadoop® sequence files, and more.

Create a datastore for a .csv file containing airline data. Treat 'NA' values as missing so that `tabularTextDatastore` replaces them with NaN values. Select the variables of interest, and specify a categorical data type for the `Origin` and `Dest` variables. Preview the contents.

```
ds = tabularTextDatastore('airlinesmall.csv');
ds.TreatAsMissing = 'NA';
ds.SelectedVariableNames = {'Year', 'Month', 'ArrDelay', 'DepDelay', 'Origin', 'Dest'};
ds.SelectedFormats(5:6) = {'%C', '%C'};
pre = preview(ds)
```

pre=8×6 table

Year	Month	ArrDelay	DepDelay	Origin	Dest
1987	10	8	12	LAX	SJC
1987	10	8	1	SJC	BUR
1987	10	21	20	SAN	SMF
1987	10	13	12	BUR	SJC
1987	10	4	-1	SMF	LAX
1987	10	59	63	LAX	SJC
1987	10	3	-2	SAN	SFO
1987	10	11	-1	SEA	LAX

Create Tall Array

Tall arrays are similar to in-memory MATLAB arrays, except that they can have any number of rows. Tall arrays can contain data that is numeric, logical, datetime, duration, calendarDuration, categorical, or strings. Also, you can convert any in-memory array to a tall array. (The in-memory array `A` must be one of the supported data types.)

The underlying class of a tall array is based on the type of datastore that backs it. For example, if the datastore `ds` contains tabular data, then `tall(ds)` returns a tall table containing the data.

```
tt = tall(ds)
```

```
tt =
```

```
Mx6 tall table
```

Year	Month	ArrDelay	DepDelay	Origin	Dest
?	?	?	?	?	?
?	?	?	?	?	?
?	?	?	?	?	?
:	:	:	:	:	:
:	:	:	:	:	:

The display indicates the underlying data type and includes the first several rows of data. The size of the table displays as "Mx6" to indicate that MATLAB does not yet know how many rows of data there are.

Perform Calculations on Tall Arrays

You can work with tall arrays and tall tables in a similar manner in which you work with in-memory MATLAB arrays and tables.

One important aspect of tall arrays is that as you work with them, MATLAB does not perform most operations immediately. These operations appear to execute quickly, because the actual computation is deferred until you specifically request output. This deferred evaluation is important because even a simple command like `size(X)` executed on a tall array with a billion rows is not a quick calculation.

As you work with tall arrays, MATLAB keeps track of all of the operations to be carried out and optimizes the number of passes through the data. Thus, it is normal to work with unevaluated tall arrays and request output only when you require it. MATLAB does not know the contents or size of unevaluated tall arrays until you request that the array be evaluated and displayed.

Calculate the mean departure delay.

```
mDep = mean(tt.DepDelay, 'omitnan')
```

```
mDep =
```

```
tall double
```

```
?
```

Gather Results into Workspace

The benefit of deferred evaluation is that when the time comes for MATLAB to perform the calculations, it is often possible to combine the operations in such a way that the number of passes

through the data is minimized. So, even if you perform many operations, MATLAB only makes extra passes through the data when absolutely necessary.

The `gather` function forces evaluation of all queued operations and brings the resulting output back into memory. Since `gather` returns the *entire* result in MATLAB, you should make sure that the result will fit in memory. For example, use `gather` on tall arrays that are the result of a function that reduces the size of the tall array, such as `sum`, `min`, `mean`, and so on.

Use `gather` to calculate the mean departure delay and bring the answer into memory. This calculation requires a single pass through the data, but other calculations might require several passes through the data. MATLAB determines the optimal number of passes for the calculation and displays this information at the command line.

```
mDep = gather(mDep)
```

```
Evaluating tall expression using the Local MATLAB Session:
```

```
- Pass 1 of 2: Completed in 1.4 sec
```

```
- Pass 2 of 2: Completed in 1.4 sec
```

```
Evaluation completed in 3.7 sec
```

```
mDep = 8.1860
```

Select Subset of Tall Array

You can extract values from a tall array by subscripting or indexing. You can index the array starting from the top or bottom, or by using a logical index. The functions `head` and `tail` are useful alternatives to indexing, enabling you to explore the first and last portions of a tall array. Gather both variables at the same time to avoid extra passes through the data.

```
h = head(tt);
tl = tail(tt);
[h,tl] = gather(h,tl)
```

```
Evaluating tall expression using the Local MATLAB Session:
```

```
- Pass 1 of 1: Completed in 1.3 sec
```

```
Evaluation completed in 1.6 sec
```

```
h=8x6 table
```

Year	Month	ArrDelay	DepDelay	Origin	Dest
1987	10	8	12	LAX	SJC
1987	10	8	1	SJC	BUR
1987	10	21	20	SAN	SMF
1987	10	13	12	BUR	SJC
1987	10	4	-1	SMF	LAX
1987	10	59	63	LAX	SJC
1987	10	3	-2	SAN	SFO
1987	10	11	-1	SEA	LAX

```
tl=8x6 table
```

Year	Month	ArrDelay	DepDelay	Origin	Dest
2008	12	14	1	DAB	ATL
2008	12	-8	-1	ATL	TPA
2008	12	1	9	ATL	CLT

```

2008    12      -8      -4      ATL      CLT
2008    12      15      -2      BOS      LGA
2008    12     -15      -1      SFO      ATL
2008    12     -12       1      DAB      ATL
2008    12      -1      11      ATL      IAD

```

Use `head` to select a subset of 10,000 rows from the data for prototyping code before scaling to the full data set.

```
ttSubset = head(tt,10000);
```

Select Data by Condition

You can use typical logical operations on tall arrays, which are useful for selecting relevant data or removing outliers with logical indexing. The logical expression creates a tall logical vector, which then is used to subscript, identifying the rows where the condition is true.

Select only the flights out of Boston by comparing the elements of the categorical variable `Origin` to the value `'BOS'`.

```
idx = (ttSubset.Origin == 'BOS');
bosflights = ttSubset(idx,:)
```

```
bosflights =
```

```
207x6 tall table
```

Year	Month	ArrDelay	DepDelay	Origin	Dest
1987	10	-8	0	BOS	LGA
1987	10	-13	-1	BOS	LGA
1987	10	12	11	BOS	BWI
1987	10	-3	0	BOS	EWR
1987	10	-5	0	BOS	ORD
1987	10	31	19	BOS	PHL
1987	10	-3	0	BOS	CLE
1987	11	5	5	BOS	STL
:	:	:	:	:	:
:	:	:	:	:	:

You can use the same indexing technique to remove rows with missing data or NaN values from the tall array.

```
idx = any(ismissing(ttSubset),2);
ttSubset(idx,:) = [];
```

Determine Largest Delays

Due to the nature of big data, sorting all of the data using traditional methods like `sort` or `sortrows` is inefficient. However, the `topkrows` function for tall arrays returns the top k rows in sorted order.

Calculate the top 10 greatest departure delays.

```
biggestDelays = topkrows(ttSubset,10,'DepDelay');
biggestDelays = gather(biggestDelays)
```

Evaluating tall expression using the Local MATLAB Session:
Evaluation completed in 0.14 sec

biggestDelays=10x6 table

Year	Month	ArrDelay	DepDelay	Origin	Dest
1988	3	772	785	ORD	LEX
1989	3	453	447	MDT	ORD
1988	12	397	425	SJU	BWI
1987	12	339	360	DEN	STL
1988	3	261	273	PHL	ROC
1988	7	261	268	BWI	PBI
1988	2	257	253	ORD	BTW
1988	3	236	240	EWR	FLL
1989	2	263	227	BNA	MOB
1989	6	224	225	DFW	JAX

Visualize Data in Tall Arrays

Plotting every point in a big data set is not feasible. For that reason, visualization of tall arrays involves reducing the number of data points using sampling or binning.

Visualize the number of flights per year with a histogram. The visualization functions pass through the data and immediately evaluate the solution when you call them, so `gather` is not required.

```
histogram(ttSubset.Year, 'BinMethod', 'integers')
```

Evaluating tall expression using the Local MATLAB Session:
Evaluation completed in 0.63 sec

```
xlabel('Year')
ylabel('Number of Flights')
title('Number of Flights by Year, 1987 - 1989')
```

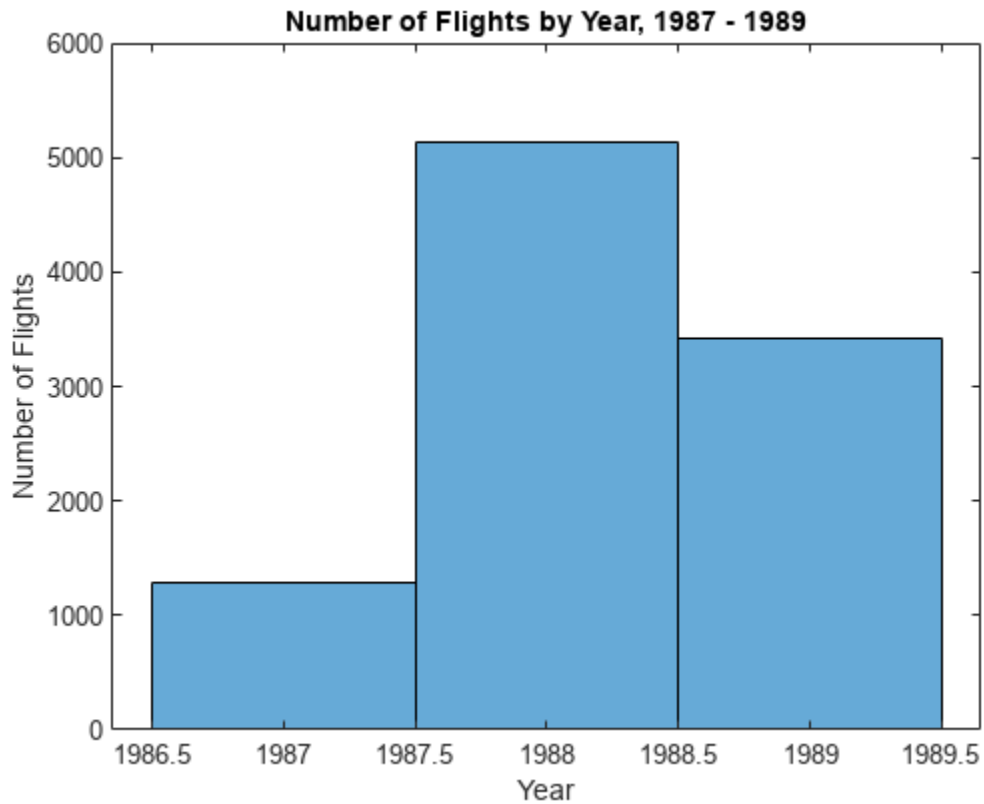

Scale to Entire Data Set

Instead of using the smaller data returned from `head`, you can scale up to perform the calculations on the entire data set by using the results from `tall(ds)`.

```
tt = tall(ds);
idx = any(ismissing(tt),2);
tt(idx,:) = [];
mnDelay = mean(tt.DepDelay,'omitnan');
biggestDelays = topkrows(tt,10,'DepDelay');
[mnDelay,biggestDelays] = gather(mnDelay,biggestDelays)
```

Evaluating `tall` expression using the Local MATLAB Session:

```
- Pass 1 of 2: Completed in 0.77 sec
- Pass 2 of 2: Completed in 1.2 sec
Evaluation completed in 2.2 sec
```

```
mnDelay = 8.1310
```

```
biggestDelays=10x6 table
```

Year	Month	ArrDelay	DepDelay	Origin	Dest
1991	3	-8	1438	MCO	BWI
1998	12	-12	1433	CVG	ORF
1995	11	1014	1014	HNL	LAX
2007	4	914	924	JFK	DTW
2001	4	887	884	MCO	DTW

2008	7	845	855	CMH	ORD
1988	3	772	785	ORD	LEX
2008	4	710	713	EWR	RDU
1998	10	679	673	MCI	DFW
2006	6	603	626	ABQ	PHX

```
histogram(tt.Year, 'BinMethod', 'integers')
```

Evaluating tall expression using the Local MATLAB Session:

```
- Pass 1 of 2: Completed in 1.9 sec
- Pass 2 of 2: Completed in 0.98 sec
```

Evaluation completed in 3.3 sec

```
xlabel('Year')
```

```
ylabel('Number of Flights')
```

```
title('Number of Flights by Year, 1987 - 2008')
```

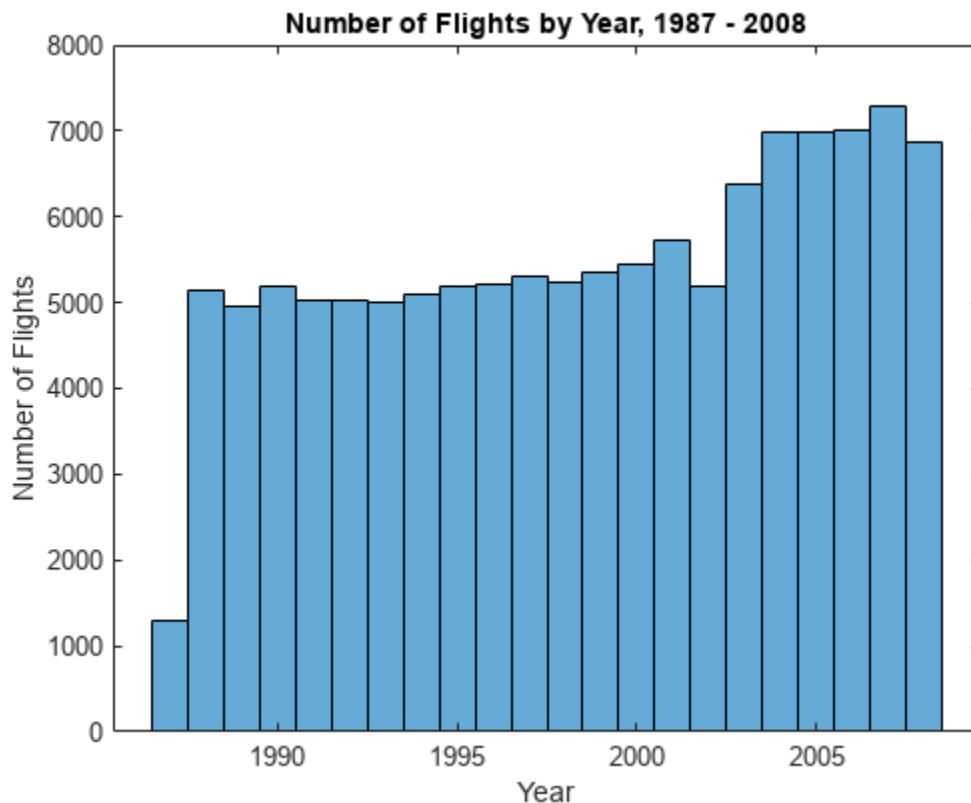

Use `histogram2` to further break down the number of flights by month for the whole data set. Since the bins for Month and Year are known ahead of time, specify the bin edges to avoid an extra pass through the data.

```
year_edges = 1986.5:2008.5;
```

```
month_edges = 0.5:12.5;
```

```
histogram2(tt.Year, tt.Month, year_edges, month_edges, 'DisplayStyle', 'tile')
```

Evaluating tall expression using the Local MATLAB Session:

```
- Pass 1 of 1: Completed in 1.6 sec
```

Evaluation completed in 1.7 sec

```

colorbar
xlabel('Year')
ylabel('Month')
title('Airline Flights by Month and Year, 1987 - 2008')

```

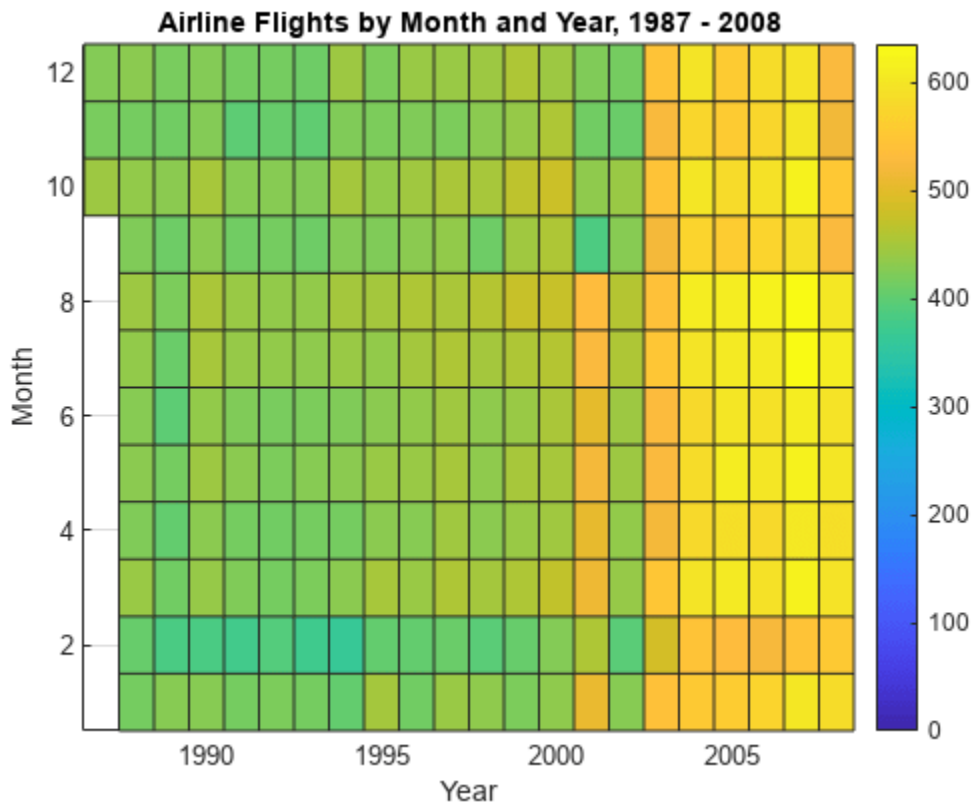

Data Analytics and Machine Learning with Tall Arrays

You can perform more sophisticated statistical analysis on tall arrays, including calculating predictive analytics and performing machine learning, using the functions in Statistics and Machine Learning Toolbox™.

For more information, see “Analysis of Big Data with Tall Arrays” (Statistics and Machine Learning Toolbox).

Scale to Big Data Systems

A key capability of tall arrays in MATLAB is the connectivity to big data platforms, such as computing clusters and Apache Spark™.

This example only scratches the surface of what is possible with tall arrays for big data. See “Extend Tall Arrays with Other Products” on page 13-185 for more information about using:

- Statistics and Machine Learning Toolbox™
- Database Toolbox™
- Parallel Computing Toolbox™

- MATLAB® Parallel Server™
- MATLAB Compiler™

See Also

tall

More About

- “Tall Arrays for Out-of-Memory Data” on page 13-146

Develop Custom Tall Array Algorithms

Tall arrays are a powerful, intuitive way to work with large data sets using traditional MATLAB syntax. However, since tall arrays operate on blocks of the data, each of which individually fits into memory, the traditional algorithms of most functions need to be updated to use a parallelized approach to support tall arrays. This topic shows you how to develop your own parallelized algorithms to operate on tall arrays.

Currently available approaches for applying custom functions to tall arrays are:

- “Single-Step Transformation Operation” on page 13-198: Apply a function to the blocks of data in a tall array.
- “Two-Step Reduction Operation” on page 13-200: Apply a function to a tall array to transform the contents, and then apply another function to reduce the output to a single block.
- “Sliding-Window Operations” on page 13-203: Apply a moving-window function to a tall array to transform the contents.

Regardless of which operation you choose, there are options, performance considerations, and common issues that apply to all approaches.

Reasons to Implement Custom Algorithms

Most common mathematical functions and MATLAB operations already support tall arrays. If the functionality is already supported, then writing your own algorithm might not be necessary.

Here are some reasons why you might want to implement a custom algorithm for tall arrays:

- **Implement Currently Unsupported Functions** — If a particular function does not currently support tall arrays, then you can use the APIs outlined here to write a version of that function that supports tall arrays.
- **Leverage Existing Code** — If you have existing code that performs some operations on in-memory data, then with only minor modifications you can make it compatible to operate on tall arrays. This approach avoids the need to convert the code to fit the subset of the MATLAB language that supports tall arrays.
- **Gain Performance** — For example, you can rewrite a MATLAB function as a C++ MEX function, and then you can use the APIs outlined here to call the MEX function to operate on the data.
- **Use a Preferred External Library** — For compatibility within your organization it is sometimes required to use a specific external library for certain calculations. You can use the APIs outlined here to reimplement a function with those external libraries.

Supported APIs

The supported APIs are intended for advanced use and do not include extensive input checking. Expect to spend some time testing that the supplemental functions you implement satisfy all of the requirements and perform the calculations you expect. Currently supported APIs for authoring tall array algorithms are listed here.

Package Function Name	Description
<code>matlab.tall.transform</code>	Apply a specified function to each block of one or more tall arrays.
<code>matlab.tall.reduce</code>	Apply a specified function to each block of one or more tall arrays. Then feed the output of that function into a second reduction function.
<code>matlab.tall.movingWindow</code>	Apply moving window function to blocks of data.
<code>matlab.tall.blockMovingWindow</code>	Apply moving window function and block reduction to padded blocks of data.

Background: Tall Array Blocks

When you create a tall array from a datastore, the underlying datastore facilitates the movement of data during a calculation. The data moves in discrete pieces called *blocks*, where each block is a set of consecutive rows that can fit in memory. For example, one block of a 2-D array (such as a table) is $X(n:m, :)$. The size of each block is based on the value of the `ReadSize` property of the datastore, but the block is not always that exact size. For the purposes of developing tall array algorithms, a tall array is considered to be the vertical concatenation of many such blocks.

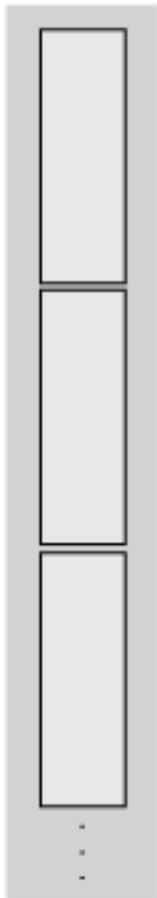

The blocks of a given array are chosen at run-time based on available memory, so they can be dynamic. Therefore, the blocks might not be *exactly* the same size between runs. If you have changes on your computer that affect the available memory, then that can impact the size of the blocks.

Although this page refers only to *blocks* and *rows* in a 2-D sense, these concepts extend to N-D tall arrays. The block size is only constrained in the first dimension, so the block includes all elements in other dimensions; for example, $X(n:m, :, :, \dots)$. Also, rather than rows, N-D arrays have *slices* such as $X(p, :, :, \dots)$.

Single-Step Transformation Operation

The `matlab.tall.transform` function applies a single function to each block of a tall array, so you can use it to apply a block-wise transformation, filtering, or reduction of the data. For example, you can remove rows with specific values, center and scale the data, or detect certain conditions and transform specific pieces of data. These figures show what happens to the blocks in an array when they are operated on by `matlab.tall.transform`.

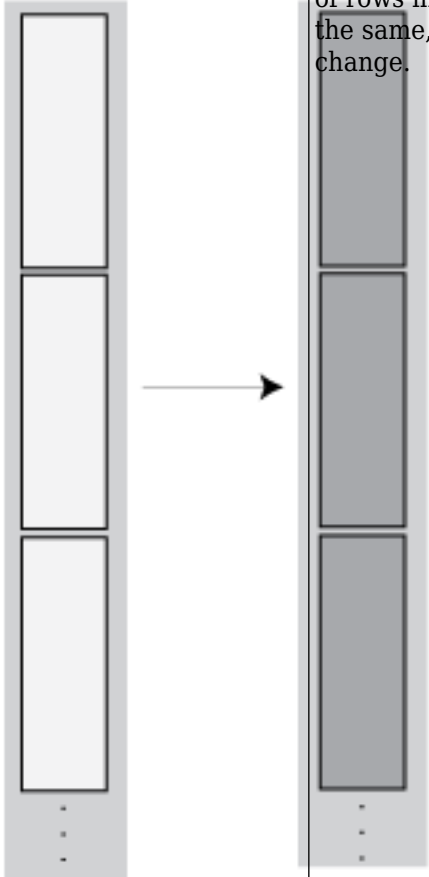
Operation	Description	Examples
	<p>Transformation — The number of rows in each block remains the same, but the values change.</p>	<ul style="list-style-type: none"> • <code>A = matlab.tall.transform(@sin, tX)</code> calculates the sine of the elements in each block. • <code>A = matlab.tall.transform(@(X) X.^2, tX)</code> squares the elements in each block.

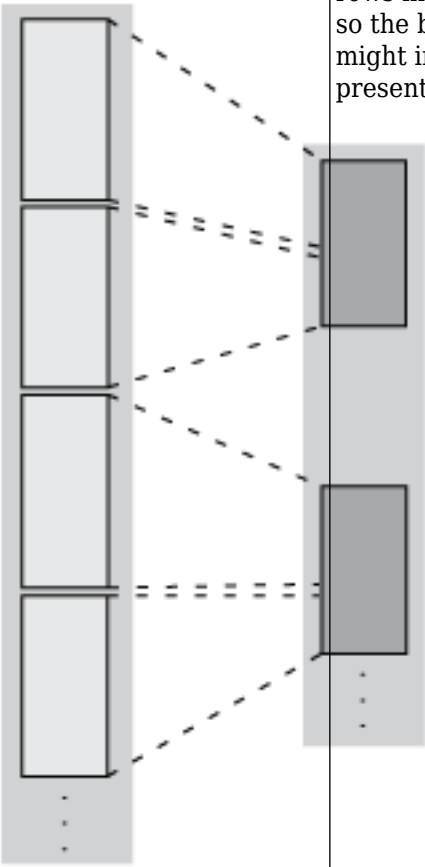
Operation	Description	Examples
	<p>Filtering — The number of rows in each block are reduced, so the blocks in the new array might include rows originally present in other blocks.</p>	<ul style="list-style-type: none"> • <code>A = matlab.tall.transform(@(X) topkrows(X,5), tX)</code> extracts only the top 5 rows from each block, filtering out the other rows. • <code>A = matlab.tall.transform(@sum, tX)</code> calculates the sum of the elements in each block, which reduces each block to a scalar. The number of elements in <code>A</code> is equal to the number of blocks.

Transform Syntax

The generic syntax to apply a single-step transform is

```
[tA, tB, tC, ...] = matlab.tall.transform(fcn, tX, tY, tZ, ...)
```

Functional Requirements for fcn

The general functional signature of `fcn` is

```
[a, b, c, ...] = fcn(x, y, z, ...)
```

`fcn` must satisfy these requirements:

- 1 **Input Arguments** — The inputs `[x, y, z, ...]` are blocks of data that fit in memory. The blocks are produced by extracting data from the respective tall array inputs `[tX, tY, tZ, ...]`. The inputs `[x, y, z, ...]` satisfy these properties:
 - All of `[x, y, z, ...]` have the same size in the first dimension after any allowed expansion.

- The blocks of data in $[x, y, z, \dots]$ come from the same index in the tall dimension, assuming the tall array is nonsingleton in the tall dimension. For example, if tX and tY are nonsingleton in the tall dimension, then the first set of blocks might be $x = tX(1:20000, :)$ and $y = tY(1:20000, :)$.
 - If the first dimension of any of $[tX, tY, tZ, \dots]$ has a size of 1, then the corresponding block $[x, y, z, \dots]$ consists of all the data in that tall array.
- 2 Output Arguments** — The outputs $[a, b, c, \dots]$ are blocks that fit in memory, to be sent to the respective outputs $[tA, tB, tC, \dots]$. The outputs $[a, b, c, \dots]$ satisfy these properties:
- All of $[a, b, c, \dots]$ must have the same size in the first dimension.
 - All of $[a, b, c, \dots]$ are vertically concatenated with the respective results of previous calls to `fcn`.
 - All of $[a, b, c, \dots]$ are sent to the same index in the first dimension in their respective destination output arrays.
- 3 Functional Rules** — `fcn` must satisfy the functional rule:
- $F([inputs1; inputs2]) == [F(inputs1); F(inputs2)]$: Applying the function to the concatenation of the inputs should be the same as applying the function to the inputs separately and then concatenating the results.
- 4 Empty Inputs** — Ensure that `fcn` can handle an input that has a height of 0. Empty inputs can occur when a file is empty or if you have done a lot of filtering on the data.

Two-Step Reduction Operation

`matlab.tall.reduce` applies two functions to a tall array, with the result of the first step being fed in as input to a final reduction step. The reduction function is applied repeatedly to the intermediate results until a single final block that fits in memory is obtained. In the MapReduce paradigm, this process is similar to a "single key" MapReduce operation, where the intermediate results all have the same key and are combined in the reduction step.

The first step is similar to `matlab.tall.transform` and has the same requirements. However, the reduction step always reduces the intermediate results down to a single block that fits in memory. These figures show what happens to the blocks in an array when they are operated on by `matlab.tall.reduce`.

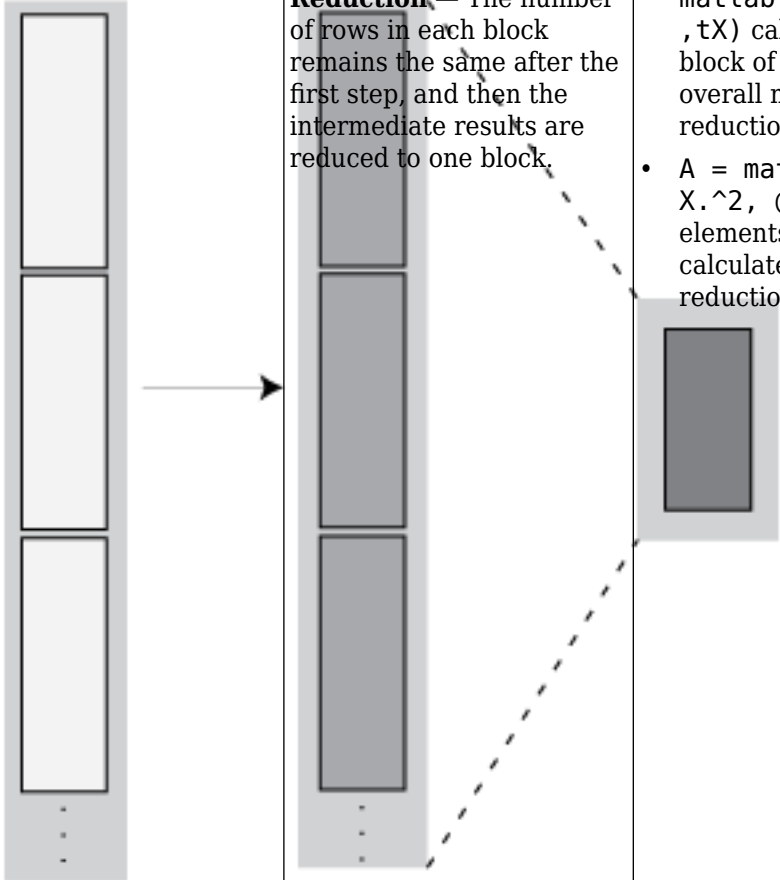
Operation	Description	Examples
	<p>Transformation + Reduction. — The number of rows in each block remains the same after the first step, and then the intermediate results are reduced to one block.</p>	<ul style="list-style-type: none"> • <code>A = matlab.tall.reduce(@sin,@max ,tX)</code> calculates the sine of each block of values, and then it finds the overall maximum value during the reduction step. • <code>A = matlab.tall.reduce(@(X) X.^2, @mean, tX)</code> squares the elements in each block, and then it calculates the overall mean in the reduction step.

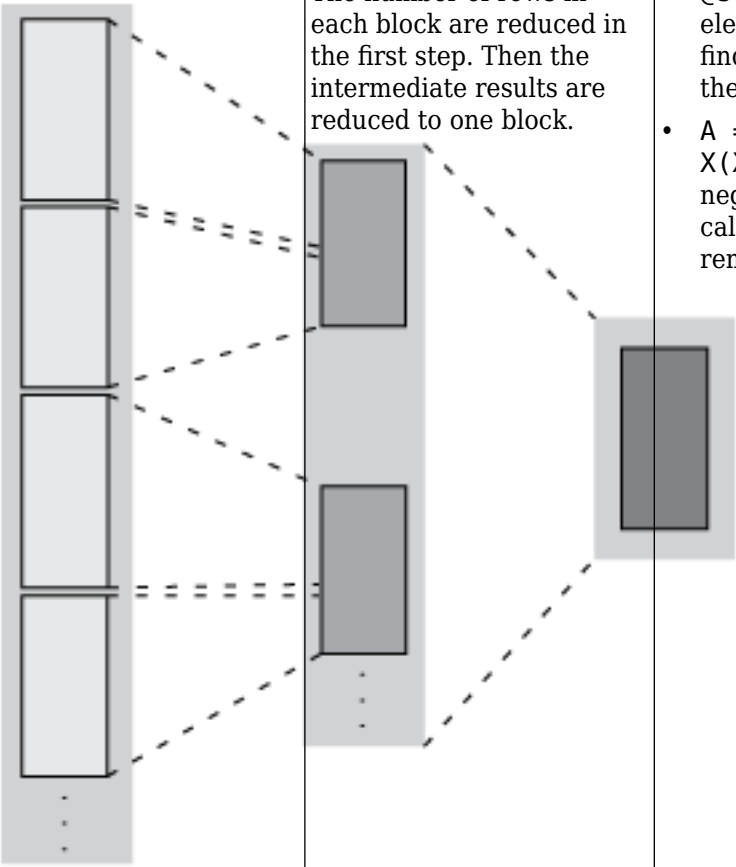
Operation	Description	Examples
	<p>Filtering + Reduction — The number of rows in each block are reduced in the first step. Then the intermediate results are reduced to one block.</p>	<ul style="list-style-type: none"> • <code>A = matlab.tall.reduce(@sum, @sum, tX)</code> calculates the sum of the elements in each block, and then it finds the overall sum of elements in the reduction step. • <code>A = matlab.tall.reduce(@(X) X(X>0), @mean, tX)</code> filters out all negative values, and then it calculates the overall mean of the remaining values.

Reduce Syntax

The generic syntax to apply a two-step reduction is

```
[rA, rB, rC, ...] = matlab.tall.reduce(fcn, reducefcn, tX, tY, tZ, ...)
```

The functional signature of `fcn` is

```
[a, b, c, ...] = fcn(x, y, z, ...)
```

The functional signature of `reducefcn` is

```
[rA, rB, rC, ...] = reducefcn(a, b, c, ...)
```

That is, the input tall arrays `[tX, tY, tZ, ...]` are broken into blocks `[x, y, z, ...]` that are inputs to `fcn`. Then, `fcn` returns outputs `[a, b, c, ...]` that are inputs to `reducefcn`. Finally, `reducefcn` returns the final results `[rA, rB, rC]` that are returned by `matlab.tall.reduce`.

Functional Requirements for `reducefcn`

The requirements for `fcn` are the same as those that were outlined in “Functional Requirements for `fcn`” on page 13-199. However, the requirements for `reducefcn` are different.

The general functional signature of `reducefcn` is

```
[rA, rB, rC, ...] = reducefcn(a, b, c, ...)
```

`reducefcn` must satisfy these requirements:

- 1 Input Arguments** — The inputs `[a, b, c, ...]` are blocks that fit in memory. The blocks of data are either outputs returned by `fcn`, or a partially reduced output from `reducefcn` that is being operated on again for further reduction. The inputs `[a, b, c, ...]` satisfy these properties:
 - The inputs `[a, b, c, ...]` have the same size in the first dimension.
 - For a given index in the first dimension, every row of the blocks of data `[a, b, c, ...]` either originates from the input, or originates from the same previous call to `reducefcn`.
 - For a given index in the first dimension, every row of the inputs `[a, b, c, ...]` for that index originates from the same index in the first dimension.
- 2 Output Arguments** — All outputs `[rA, rB, rC, ...]` must have the same size in the first dimension. Additionally, they must be vertically concatenable with the respective inputs `[a, b, c, ...]` to allow for repeated reductions when necessary.
- 3 Functional Rules** — `reducefcn` must satisfy these functional rules (up to roundoff error):
 - $F(\text{input}) == F(F(\text{input}))$: Applying the function repeatedly to the same inputs should not change the result.
 - $F([\text{input1}; \text{input2}]) == F([\text{input2}; \text{input1}])$: The result should not depend on the order of concatenation.
 - $F([\text{input1}; \text{input2}]) == F([F(\text{input1}); F(\text{input2})])$: Applying the function once to the concatenation of some intermediate results should be the same as applying it separately, concatenating, and applying it again.
- 4 Empty Inputs** — Ensure that `reducefcn` can handle an input that has a height of 0. Empty inputs can occur when a file is empty or if you have done a lot of filtering on the data. For this call, all input blocks are empty arrays of the correct type and size in dimensions beyond the first.

Sliding-Window Operations

The `matlab.tall.movingWindow` and `matlab.tall.blockMovingWindow` functions apply a function to windows of data within a tall array. While `matlab.tall.transform` and `matlab.tall.reduce` operate on entire blocks of data at a time, the moving-window functions operate on windows of data as a window moves from the beginning to the end of the array. The windows can span between the blocks of data being read from disk.

These figures show what happens to the blocks in an array when they are operated on by `matlab.tall.movingWindow` or `matlab.tall.blockMovingWindow`.

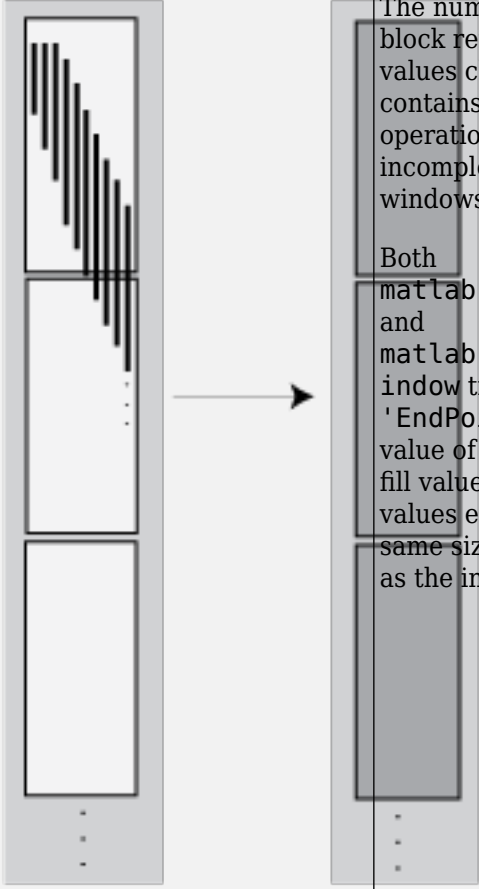
Operation	Description	Examples
	<p>Windowed Transformation — The number of rows in each block remains the same, but the values change. The output contains the results of operations performed on both incomplete and complete windows of data.</p> <p>Both <code>matlab.tall.movingWindow</code> and <code>matlab.tall.blockMovingWindow</code> transform data when 'EndPoints' is the default value of 'shrink', or when a fill value is specified. Both values ensure the output is the same size in the first dimension as the input.</p>	<ul style="list-style-type: none"> • <code>A = matlab.tall.movingWindow(@mean, 100, tX)</code> calculates a moving mean using a window size of 100.

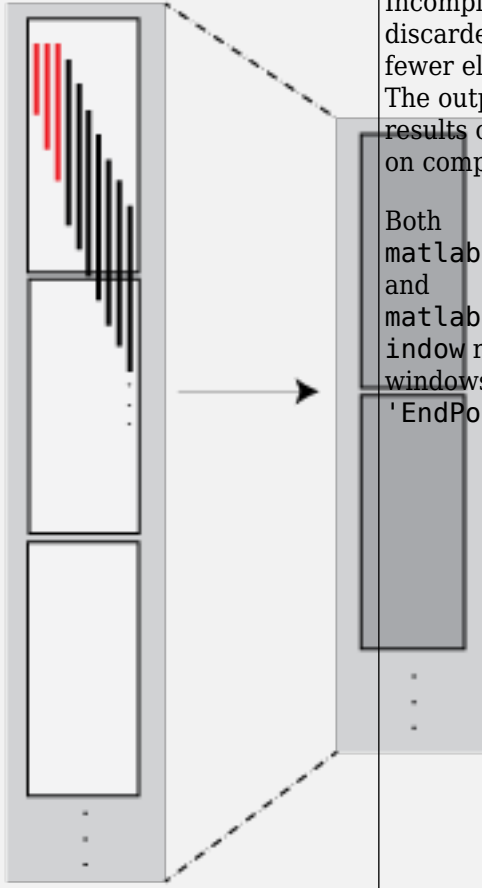
Operation	Description	Examples
	<p>Windowed Filtering — Incomplete windows of data are discarded, so the output has fewer elements than the input. The output only contains the results of operations performed on complete windows of data.</p> <p>Both <code>matlab.tall.movingWindow</code> and <code>matlab.tall.blockMovingWindow</code> remove incomplete windows of data when 'EndPoints' is 'discard'.</p>	<ul style="list-style-type: none"> • <code>A = matlab.tall.movingWindow(@mean, 100, tX, 'EndPoints', 'discard')</code> calculates a moving mean on complete windows of data, using a window size of 100.

You can use `matlab.tall.movingWindow` and `matlab.tall.blockMovingWindow` to apply windowed transformations or filters to data. For example, you can calculate a trailing average or a moving median, or you can apply several operations at once to the same window. The two functions differ in these ways:

- `matlab.tall.movingWindow` applies `fcn` to all windows of data, regardless of whether the windows are complete. `matlab.tall.blockMovingWindow` applies `windowfcn` to incomplete windows of data, and applies `blockfcn` to complete windows of data.
- `matlab.tall.movingWindow` operates on single windows of data at a time. `matlab.tall.blockMovingWindow` operates on entire blocks of data containing multiple complete windows, which reduces the number of function calls required in the calculation.

Moving Window Syntaxes

The syntax to apply a moving window operation to single windows of data is

```
[tA, tB, tC, ...] = matlab.tall.movingWindow(fcn, window, tX, tY, tZ, ...)
```

The functional signature of `fcn` must be

```
[a, b, c, ...] = fcn(x, y, z, ...)
```

Similarly, the syntax to apply a moving window operation to entire blocks of data is

```
[tA, tB, tC, ...] = matlab.tall.blockMovingWindow(windowfcn, blockfcn, window, tX, tY, tZ, ...)
```

The functional signatures of `windowfcn` and `blockfcn` must be

```
[a, b, c, ...] = windowfcn(info, x, y, z, ...)
[a, b, c, ...] = blockfcn(info, bX, bY, bZ, ...)
```

The `info` input is a structure that contains the fields `Window` and `Stride`. When you write the function, use these fields to pick out windows of data in each block.

For an outline of general rules that `fcn`, `windowfcn`, and `blockfcn` must follow, see “Functional Requirements for `fcn`” on page 13-199. Aside from the `info` input, `fcn` and `windowfcn` have the same requirements. However, the requirements for `blockfcn` are different since that function operates on entire blocks of data.

Functional Requirements for `windowfcn`

The general functional signature of `windowfcn` is

```
[a, b, c, ...] = windowfcn(info, x, y, ...)
```

The `info` input is a structure provided by `matlab.tall.blockMovingWindow` that includes these fields:

- `Stride` — Specified step size between windows (default: 1). Set this value with the 'Stride' name-value pair.
- `Window` — Specified window size. Set this value with the `window` input argument.

`windowfcn` must satisfy these requirements:

- 1 **Input Arguments** — The inputs `[x, y, z, ...]` are blocks of data that fit in memory. The blocks are produced by extracting data from the respective tall array inputs `[tX, tY, tZ, ...]`. The inputs `[x, y, z, ...]` satisfy these properties:
 - All of the inputs `[x, y, z, ...]` have the same size in the first dimension.
 - The blocks of data in `[x, y, z, ...]` come from the same index in the tall dimension, assuming the tall array is nonsingleton in the tall dimension. For example, if `tX` and `tY` are nonsingleton in the tall dimension, then the first set of blocks might be `x = tX(1:20000,:)` and `y = tY(1:20000,:)`.
 - When the first dimension of any of `[tX, tY, tZ, ...]` has a size of 1, the corresponding block `[x, y, z, ...]` consists of all the data in that tall array.
 - Applying `windowfcn` must result in a reduction of the input data to a scalar or a slice of an array of height 1.

When the input is a matrix, N-D array, table, or timetable, applying `windowfcn` must result in a reduction of the input data in each of its columns or variables.

- 2 **Output Arguments** — The outputs `[a, b, c, ...]` are blocks that fit in memory to be sent to the respective outputs `[tA, tB, tC, ...]`. The outputs `[a, b, c, ...]` satisfy these properties:
 - All of the outputs `[a, b, c, ...]` must have the same size in the first dimension.

- All of the outputs [a, b, c, ...] are vertically concatenated with the respective results of previous calls to `windowfcn`.
- All of the outputs [a, b, c, ...] are sent to the same index in the first dimension in their respective destination output arrays.

3 Functional Rules — `windowfcn` must satisfy this functional rule:

- $F([\text{inputs1}; \text{inputs2}]) == [F(\text{inputs1}); F(\text{inputs2})]$: Applying the function to the concatenation of the inputs should be the same as applying the function to the inputs separately and then concatenating the results.

Functional Requirements for `blockfcn`

The general functional signature of `blockfcn` is

```
[a, b, c, ...] = blockfcn(info, bX, bY, bZ, ...)
```

The `info` input is a structure provided by `matlab.tall.blockMovingWindow` that includes these fields:

- `Stride` — Specified step size between windows (default: 1). Set this value with the 'Stride' name-value pair.
- `Window` — Specified window size. Set this value with the `window` input argument.

The blocks of data `bX`, `bY`, `bZ`, ... that `matlab.tall.blockMovingWindow` provides to `blockfcn` have these properties:

- The blocks contain only full-sized windows. `blockfcn` does not have to define a behavior for incomplete windows of data.
- The first window of data starts at the first element of the block. The last element of the last window is the last element of the block.

`blockfcn` must satisfy these requirements:

1 Input Arguments — The inputs [bX, bY, bZ, ...] are blocks of data that fit in memory. The blocks are produced by extracting data from the respective tall array inputs [tX, tY, tZ, ...]. The inputs [bX, bY, bZ, ...] satisfy these properties:

- All of the inputs [bX, bY, bZ, ...] have the same size in the first dimension after any allowed expansion.
- The blocks of data in [bX, bY, bZ, ...] come from the same index in the tall dimension, assuming the tall array is nonsingleton in the tall dimension. For example, if `tX` and `tY` are nonsingleton in the tall dimension, then the first set of blocks might be `bX = tX(1:20000, :)` and `bY = tY(1:20000, :)`.
- If the first dimension of any of the data inputs [tX, tY, tZ, ...] has a size of 1, then the corresponding block [bX, bY, bZ, ...] consists of all the data in that tall array.
- Applying `blockfcn` must result in a reduction of the input data such that the result has height equal to the number of windows in the block. You can use `info.Window` and `info.Stride` to determine the number of windows in a block.

If the input is a matrix, N-D array, table, or timetable, then applying `blockfcn` must result in a reduction of the input data in each of its columns or variables.

- 2 Output Arguments** — The outputs [a, b, c, ...] are blocks that fit in memory, to be sent to the respective outputs [tA, tB, tC, ...]. The outputs [a, b, c, ...] satisfy these properties:
- All of the outputs [a, b, c, ...] must have the same size in the first dimension.
 - All of the outputs [a, b, c, ...] are vertically concatenated with the respective results of previous calls to `blockfcn`.
 - All of the outputs [a, b, c, ...] are sent to the same index in the first dimension in their respective destination output arrays.
- 3 Functional Rules** — `blockfcn` must satisfy this functional rule:
- $F([inputs1; inputs2]) == [F(inputs1); F(inputs2)]$: Applying the function to the concatenation of the inputs should be the same as applying the function to the inputs separately and then concatenating the results.

Control Output Data Type

If the final output from any of the “Supported APIs” on page 13-196 has a different data type from the input, then you *must* specify the 'OutputsLike' name-value pair to provide one or more prototype arrays that have the same data type and attributes as the corresponding outputs. The value of 'OutputsLike' is always a cell array, with each cell containing a prototype array for the corresponding output argument.

For example, this call to `matlab.tall.transform` accepts one tall array `tX` as an input and returns two outputs with different types specified by the prototype arrays `protoA` and `protoB`. Output A has the same data type and attributes as `protoA`, and likewise for B and `protoB`.

```
C = {protoA protoB};
[A, B] = matlab.tall.transform(fcn, tX, 'OutputsLike', C)
```

A common way to supply the prototype arrays is to call `fcn` with trivial inputs of the proper data type, since the outputs returned by `fcn` have the correct data type. In this example, the transform function accepts a tall double, but returns a tall table. A prototype array is generated by calling `fcn(0)` and the prototype is specified as the value of 'OutputsLike'.

```
ds = tabularTextDatastore('airlinesmall.csv','TreatAsMissing','NA');
ds.SelectedVariableNames = {'ArrDelay', 'DepDelay'};
tt = tall(ds);
tX = tt.ArrDelay;
```

```
fcn = @(x) table(x,'VariableNames',{'MyVar'});
proto_A = fcn(0);
A = matlab.tall.transform(fcn,tX,'OutputsLike',{proto_A});
```

Coding and Performance Tips

- Put all analytics in a single function that you call to operate directly on the data, instead of using unnecessary nested functions.
- Experiment using a small subset of the data. Profile your code to find and fix bottlenecks before scaling up to the entire data set, where bottlenecks can be greatly amplified.
- Pay attention to the orientation of your data, since some functions return the outputs in different shapes depending on the input data. For example, `unique` can return either a row vector or a column vector depending on the orientation of the input data.

- Blocks are dynamically generated at run-time based on available computer memory. Make sure that any specified reduction function obeys the function rule $F([\text{input1}; \text{input2}]) == F(F(\text{input1}); F(\text{input2}))$. If this rule is not obeyed, then the results can differ significantly between trials.
- Blocks can have any size in the first dimension, including 0 or 1. Size 0 or 1 can occur in intermediate calculations as a result of filtering or reduction operations. Make sure your function does the correct thing for both of these cases. One sign that the function does not handle these cases properly is when you receive an "Output is different size" error message.

See Also

`matlab.tall.reduce` | `matlab.tall.transform` | `matlab.tall.movingWindow` | `matlab.tall.blockMovingWindow`

More About

- "Index and View Tall Array Elements" on page 13-157
- "Visualization of Tall Arrays" on page 13-171
- "Extend Tall Arrays with Other Products" on page 13-185

TCP/IP Support in MATLAB

- “TCP/IP Communication Overview” on page 14-2
- “Create TCP/IP Client and Configure Settings” on page 14-3
- “Write and Read Data over TCP/IP Interface” on page 14-7
- “Use Callbacks for TCP/IP Communication” on page 14-10
- “Configure Connection in TCP/IP Explorer” on page 14-11
- “Communicate Binary and ASCII Data to an Echo Server Using TCP/IP” on page 14-12
- “Troubleshooting TCP/IP Client Interface” on page 14-15
- “Resolve TCP/IP Client Connection Errors” on page 14-17
- “Resolve TCP/IP Client Warning: Unable to Read Any Data” on page 14-19

TCP/IP Communication Overview

Transmission Control Protocol (TCP) is a transport protocol layered on top of the Internet Protocol (IP) and is one of the most used networking protocols. The MATLAB TCP/IP client support uses raw socket communication and lets you connect to remote hosts from MATLAB for reading and writing data. For example, you can connect to a remote weather station, acquire data, and plot the data.

- **Connection-based protocol** — The two ends of the communication link must be connected at all times during the communication.
- **Streaming protocol** — TCP/IP has a long stream of data that is transmitted from one end of the connection to the other end, and another long stream of data flowing in the opposite direction. The TCP/IP stack at one end is responsible for breaking the stream of data into packets and sending those packets, while the stack at the other end is responsible for reassembling the packets into a data stream using information in the packet headers.
- **Reliable protocol** — The packets sent by TCP/IP contain a unique sequence number. The starting sequence number is communicated to the other side at the beginning of communication. The receiver acknowledges each packet, and the acknowledgment contains the sequence number so that the sender knows which packet was acknowledged. Because the sender gets an acknowledgment for each packet received, the sender knows when packets do not arrive and can retransmit them. Also, packets that arrive out of sequence can be reassembled in the proper order by the receiver.

Timeouts can be established because the sender knows (from the first few packets) how long it takes on average for a packet to be sent and its acknowledgment received.

You can create a TCP/IP connection to a server or hardware and perform read/write operations. Use the `tcpclient` function to create the connection, and the `write` and `read` functions for synchronously reading and writing data.

See Also

`tcpclient`

More About

- “Create TCP/IP Client and Configure Settings” on page 14-3
- “Write and Read Data over TCP/IP Interface” on page 14-7

Create TCP/IP Client and Configure Settings

MATLAB TCP/IP client support lets you connect to remote hosts or hardware from MATLAB for reading and writing data. The typical workflow is:

- Create a TCP/IP connection to a server or hardware.
- Configure the connection if necessary.
- Perform read and write operations.
- Clear and close the connection.

To communicate over the TCP/IP interface, first create a `tcpclient` object.

```
t = tcpclient(address,port);
```

The address can be either a remote host name or a remote IP address. In both cases, the port must be a positive integer between 1 and 65535.

Create Object Using Host Name

Create the TCP/IP object `t` using the host address shown and port 80.

```
t = tcpclient("www.mathworks.com",80)

t =
  tcpclient with properties:

      Address: 'www.mathworks.com'
      Port: 80
  NumBytesAvailable: 0

  Show all properties, functions
```

When you connect using a host name, such as a specified web address or `'localhost'`, the IP address defaults to IPv6 format. If the server you are connecting to is expecting IPv4 format, connection fails. For IPv4, you can create a connection by specifying an explicit IP address rather than a host name.

Create Object Using IP Address

Create the TCP/IP object `t` using the IP address shown and port 80.

```
t = tcpclient("144.212.130.17",80)

t =
  tcpclient with properties:

      Address: '144.212.130.17'
      Port: 80
  NumBytesAvailable: 0

  Show all properties, functions
```

Set Timeout Property

Create the object and use a name-value pair argument to set the `Timeout` value. The `Timeout` parameter specifies the waiting time to complete read and write operations in seconds, and the default value is 10. You can change the value either during object creation or after you create the object.

Create a TCP/IP object with a timeout of 20 seconds.

```
t = tcpclient("144.212.130.17",80,"Timeout",20)
```

```
t =  
tcpclient with properties:  
  
    Address: '144.212.130.17'  
    Port: 80  
    NumBytesAvailable: 0  
  
Show all properties, functions
```

View the `Timeout` property.

```
t.Timeout
```

```
ans =  
  
    20
```

The output reflects the `Timeout` property change.

Set Connect Timeout Property

Create the object and use a name-value pair argument to set the `ConnectTimeout` value. The `ConnectTimeout` parameter specifies the maximum time in seconds to wait for a connection request to the specified remote host to succeed or fail. The value must be greater than or equal to 1. If you do not specify `ConnectTimeout`, it has the default value of `Inf`. You can specify the value only during object creation.

Create a TCP/IP object and specify `ConnectTimeout` as 10 seconds.

```
t = tcpclient("144.212.130.17",80,"ConnectTimeout",10)
```

```
t =  
tcpclient with properties:  
  
    Address: '144.212.130.17'  
    Port: 80  
    NumBytesAvailable: 0  
  
Show all properties, functions
```

View the `ConnectTimeout` property.

```
t.ConnectTimeout
```

```
ans =
    10
```

The output reflects the `ConnectTimeout` property change.

Note If you specify an invalid address or port or the connection to the server cannot be established, the object is not created.

Set Transfer Delay Property

Create the object and use a name-value pair argument to set the `EnableTransferDelay` value. The `EnableTransferDelay` parameter specifies whether Nagle's algorithm is on or off. If transfer delay is enabled, the client collects small segments of outstanding data and sends them in a single packet when acknowledgement (ACK) arrives from the server. If transfer delay is disabled, the client immediately sends data to the network. If you do not specify `EnableTransferDelay`, it is `true` by default. You can specify the value only during object creation.

Create a TCP/IP object with transfer delay disabled.

```
t = tcpclient("144.212.130.17",80,"EnableTransferDelay",false)

t =
    tcpclient with properties:

        Address: '144.212.130.17'
        Port: 80
        NumBytesAvailable: 0

    Show all properties, functions
```

View the `EnableTransferDelay` property.

```
t.EnableTransferDelay
```

```
ans =
    logical
    0
```

The output reflects the `EnableTransferDelay` property change.

View TCP/IP Object Properties

After you create a `tcpclient` object, you can view a full list of properties and their values. Click `properties` in the `tcpclient` output.

```
t = tcpclient("www.mathworks.com",80)

t =
    tcpclient with properties:
```

```
        Address: 'www.mathworks.com'  
        Port: 80  
NumBytesAvailable: 0
```

Show all properties, functions

```
        Address: 'www.mathworks.com'  
        Port: 80  
NumBytesAvailable: 0  
  
ConnectTimeout: Inf  
Timeout: 10  
ByteOrder: "little-endian"  
Terminator: "LF"  
  
BytesAvailableFcnMode: "off"  
BytesAvailableFcnCount: 64  
BytesAvailableFcn: []  
NumBytesWritten: 0  
  
EnableTransferDelay: 1  
ErrorOccurredFcn: []  
UserData: []
```

For more information about how to configure these properties, see “Properties”.

You can use the `configureTerminator` and `configureCallback` functions to configure certain properties.

See Also

`tcpclient`

More About

- “Write and Read Data over TCP/IP Interface” on page 14-7

Write and Read Data over TCP/IP Interface

In this section...

“Write Data” on page 14-7

“Read Data” on page 14-7

“Acquire Data from Weather Station Server” on page 14-8

“Read Page from Website” on page 14-8

Write Data

The `write` function synchronously writes data to the remote host connected to the `tcpclient` object. First specify the data, then write the data. The function waits until the specified number of values is written to the remote host.

In this example, a `tcpclient` object `t` already exists.

```
% Create a variable called data
data = 1:10;

% Write the data to the object t
write(t, data)
```

Note For any read or write operation, the data type is converted to `uint8` for the data transfer. It is then converted back to the data type you set if you specified another data type.

Read Data

The `read` function synchronously reads data from the remote host connected to the `tcpclient` object and returns the data. There are three read options:

- Read all bytes available (no arguments).
- Optionally specify the number of bytes to read.
- Optionally specify the data type.

If you do not specify a size, the default read uses the `BytesAvailable` property value, which is equal to the number of bytes available in the input buffer.

In these examples, a `tcpclient` object `t` already exists.

```
% Read all bytes available.
read(t)

% Specify the number of bytes to read, 5 in this case.
read(t,5)

% Specify the number of bytes to read, 10, and the data type, double.
read(t,10,"double")
```

Note For any read or write operation, the data type is converted to `uint8` for the data transfer. It is then converted back to the data type you set if you specified another data type.

Acquire Data from Weather Station Server

One of the primary uses of TCP/IP communication is to acquire data from a server. This example shows how to acquire and plot data from a remote weather station.

Note The IP address in this example is not a working IP address. The example shows how to connect to a remote server. Substitute the address shown here with the IP address or host name of a server you want to communicate with.

- 1 Create the `tcpclient` object using the address shown here and port 1045.

```
t = tcpclient("172.28.154.231",1045)

t =
  tcpclient with properties:
    Address: '172.28.154.231'
    Port: 1045
    NumBytesAvailable: 0

  Show all properties, functions
```

- 2 Acquire data using the `read` function. Specify the number of bytes to read as 30, for 10 samples from three sensors (temperature, pressure, and humidity). Specify the data type as `double`.

```
data = read(t,30,"double");
```

- 3 Reshape the 1-by-30 data into 10-by-3 data to show one column each for temperature, pressure, and humidity.

```
data = reshape(data,[3,10]);
```

- 4 Plot the temperature.

```
subplot(311);
plot(data(:,1));
```

- 5 Plot the pressure.

```
subplot(312);
plot(data(:,2));
```

- 6 Plot the humidity.

```
subplot(313);
plot(data(:,3));
```

- 7 Close the connection between the TCP/IP client object and the remote host by clearing the object.

```
clear t
```

Read Page from Website

In this example, you read a page from the RFC Editor Web site using a TCP/IP object.

- 1 Create a TCP/IP object. Port 80 is the standard port for web servers.

```
t = tcpclient("www.rfc-editor.org",80);
```

Set the Terminator property of the TCP/IP object.

```
configureTerminator(t, "LF", "CR/LF");
```

- 2 You can now communicate with the server using the `writeline` and `readline` functions.

To ask a web server to send a web page, use the GET command. You can ask for a text file from the RFC Editor Web site using 'GET (*path/filename*)'.

```
writeline(t, "GET /rfc/rfc793.txt");
```

The server receives the command and sends back the web page. You can see if any data was sent back by looking at the `NumBytesAvailable` property of the object.

```
t.NumBytesAvailable
```

Now you can start to read the web page data. By default, `readline` reads one line at a time. You can read lines of data until the `NumBytesAvailable` value is 0. Note that you do not see a rendered web page; the HTML file data scrolls by on the screen.

```
while (t.NumBytesAvailable > 0)
    A = readline(t)
end
```

- 3 If you want to do more communication, you can continue to read and write data. If you are done with the object, clear it.

```
clear t
```

See Also

`read` | `readline` | `write` | `writeline`

Use Callbacks for TCP/IP Communication

You can enhance the power and flexibility of your TCP/IP client by using events and callbacks. An event occurs after a condition is met and can result in one or more callbacks.

While MATLAB is connected to a remote host with a TCP/IP client, you can use events to display a message, display data, analyze data, and so on. You can control callbacks through callback properties and callback functions. All event types have an associated callback property. Callback functions are MATLAB functions that you write to suit your specific application needs. Execute a callback when a particular event occurs by specifying the name of the callback function as the value for the associated callback property.

For an example of configuring callbacks with the `tcpclient` object, see “Communicate Binary and ASCII Data to an Echo Server Using TCP/IP” on page 14-12.

The `tcpclient` properties and functions associated with callbacks follow.

Property or Function	Purpose
<code>NumBytesAvailable</code>	Number of bytes available to read
<code>BytesAvailableFcn</code>	Bytes available callback function
<code>BytesAvailableFcnCount</code>	Number of bytes of data to trigger callback
<code>BytesAvailableFcnMode</code>	Bytes available callback trigger mode
<code>configureCallback</code>	Set callback function and trigger condition for communication with remote host over TCP/IP
<code>ErrorOccurredFcn</code>	Callback function triggered by error event
<code>UserData</code>	General purpose property for user data

See Also

More About

- “Communicate Binary and ASCII Data to an Echo Server Using TCP/IP” on page 14-12

Configure Connection in TCP/IP Explorer

After you select **Configure TCP/IP Connection**, the **Configure** tab opens. Set the following connection parameters for the TCP/IP server that you want to connect to.

- **Address** — Server name or IP address.
- **Port** — Server port, specified as a number between 1 and 65535, inclusive.
- **Connect Timeout** — Allowed time in seconds to connect to the server, specified as a numeric value. This parameter specifies the maximum time to wait for a connection request to the specified server to succeed or fail.
- **Transfer Delay** — Allow delayed acknowledgement from server. If this parameter is enabled, Nagle's algorithm is on and the client sends small segments of collected data in a single packet when acknowledgement (ACK) arrives from the server. If this parameter is disabled, Nagle's algorithm is off and the client immediately sends data to the network.

After you have specified values for these parameters, click **Confirm Parameters**. If the connection is successful, your TCP/IP Connection appears in the **Device List**.

Go back to device selection at any time by clicking **Cancel**.

See Also

Communicate Binary and ASCII Data to an Echo Server Using TCP/IP

This example shows how to set up an echo server and communicate with it using TCP/IP by creating a `tcpclient` object. Binary data and terminated string data are sent to the server and the server echoes the same data back to the client.

Set Up TCP/IP Echo Server and Client

Create a TCP/IP echo server on port 4500.

```
echo tcpip("on",4500);
```

Create a `tcpclient` object and connect to the server. Specify the remote host as "localhost" to connect to the echo server. Specify the same remote port number you used for the echo server.

```
t = tcpclient("localhost",4500)
```

```
t =  
tcpclient with properties:  
    Address: 'localhost'  
    Port: 4500  
    NumBytesAvailable: 0
```

```
Show all properties, functions
```

Write and Read Binary Data Using Byte Callback Mode

Create a callback function called `readDataFcn` to read data each time the specified bytes of data are available. Store the read data in the `UserData` property of `tcpclient` object. See the `readDataFcn` function at the end of this example.

Set the callback function to trigger each time 10 bytes of data are received.

```
configureCallback(t,"byte",10,@readDataFcn);
```

Send 10 bytes of data to the echo server.

```
sendData = 1:10;  
write(t,sendData,"uint8");
```

The echo server sends the binary data back to the TCP/IP client.

Pause for 1 second to allow the callback function `readDataFcn` to complete its operation.

```
pause(1);
```

Read binary data stored in `UserData` property and display it.

```
data = t.UserData  
data = 1x10 uint8 row vector
```

```
1 2 3 4 5 6 7 8 9 10
```

This data matches the data you wrote to the echo server.

Write and Read ASCII Data Using Terminator Callback Mode

Create a callback function called `readASCIIIFcn` to read data each time a terminator is found in the data. Store the read data in the `UserData` property of `tcpclient` object. See the `readASCIIIFcn` function at the end of this example.

Set the callback function to read terminated string data. The callback is triggered when it receives a terminator in the data.

```
configureCallback(t,"terminator",@readASCIIIFcn);
```

Set the `Terminator` property value to "LF".

```
configureTerminator(t,"LF");
```

Send string data to the echo server using `writeline`. The terminator character "LF" is automatically appended to this string data.

```
writeline(t,"Echo this string.");
```

The echo server sends the ASCII data back to the TCP/IP client.

Pause for 1 second to allow the callback function `readASCIIIFcn` to complete its operation.

```
pause(1);
```

Read ASCII data stored in `UserData` property and display it.

```
textData = t.UserData
```

```
textData =  
"Echo this string."
```

This data matches the data you wrote to the echo server.

Clear the Connection

Stop the echo server and clear the `tcpclient` object.

```
echotcpip("off");  
clear t
```

Callback Functions

Callback Function to Read Binary Data

This function calls `read` to read `BytesAvailableFcnCount` number of bytes of data. This data is echoed back by the server.

```
function readDataFcn(src, ~)  
src.UserData = read(src,src.BytesAvailableFcnCount,"uint8");  
end
```

Callback Function to Read ASCII Data

This function calls `readline` to read ASCII data originally sent by the `tcpclient` object. The data is echoed back by the server.

```
function readASCIIFcn(src, ~)
src.UserData = readline(src);
end
```

Troubleshooting TCP/IP Client Interface

Transmission Control Protocol (TCP) is a transport protocol layered on top of the Internet Protocol (IP) and is one of the most highly used networking protocols. You can use network socket communication to connect to remote hosts to read and write data.

Issue

If you are having trouble connecting to or communicating with your remote host, try these troubleshooting tips.

Possible Solutions

Supported Platforms

TCP/IP is supported on these platforms:

- Linux
- macOS
- Windows 10

The TCP/IP client interface is supported on the same platforms as MATLAB. For updates to the list of currently supported platforms, see System Requirements.

Configuration and Connection

- 1 Make sure you can create your TCP/IP client object. You create a client object with the `tcpclient` function, which requires the name of the remote host as an input argument. You also need to specify the remote port value.

Each client object is associated with one instrument. For example, to create a client object for a Sony/Tektronix AWG520 Arbitrary Waveform Generator, you use the remote host name of the instrument and the port number, which can be found in the instrument documentation.

```
t = tcpclient("sonytekawg.yourdomain.com",4000);
```

- 2 After you connect to the device, you can communicate with it. If sending and receiving does not work, you can check the following:
 - Make sure the data is being sent in the format expected by the server.
 - If you connect to a web server, you might need to send HTTP `get` or `post` commands. You can also use the `urlread` or `webread` functions to communicate with web servers.
 - Many TCP/IP servers expect header information inside the TCP/IP packet.

See “Write and Read Data over TCP/IP Interface” on page 14-7 for an example of communication over TCP/IP.

VISA-TCP/IP Communication

You can also use the `visadev` interface with a VISA-TCP/IP resource name instead of the `tcpclient` interface for TCP/IP communication with instruments.

Incorrect Data Type

Make sure the correct data type—for example `int16`, `uint16`, `double`—is being used with `read` and `write`. Use the same data type as the instrument. If reading and writing data types other than `uint8` or `int8`, make sure the `ByteOrder` is correct.

See Also

`tcpclient`

Related Examples

- “Resolve TCP/IP Client Connection Errors” on page 14-17
- “Resolve TCP/IP Client Warning: Unable to Read Any Data” on page 14-19

Resolve TCP/IP Client Connection Errors

Issue

If you are unable to create a TCP/IP client using the `tcpclient` interface, follow these troubleshooting steps.

Possible Solutions

Check IP Address and Port

- If your instrument supports TCP socket communication by allowing control and communication on a static TCP/IP port, the port number is typically set by the manufacturer. However, you might need to enable a TCP socket server on the instrument. Run the following commands in MATLAB with your remote host IP address or host name and port. In this example, the remote host IP address is `192.168.1.111` and port is `4000`.

- 1 Check that the IP address or host name you specified can be reached.

```
!ping 192.168.1.111
```

- 2 Check that the port is accessible using Telnet or another application that supports Telnet, such as PuTTY.

```
!telnet 192.168.1.111 4000
```

- Verify that the specified IP address or host name is valid by using `resolvehost`. If the output is empty, the specified IP address or host name is invalid. For example, if the host name is `en.wikipedia.org`, run the following.

```
[name,address] = resolvehost("en.wikipedia.org")
```

```
name =
```

```
    'en.wikipedia.org'
```

```
address =
```

```
    '208.80.154.224'
```

- Make sure that you specified the correct port number. Refer to your instrument manual or contact your instrument manufacturer to check the port number.
- Check that a TCP socket server is listening at the specified port. For example, on certain Tektronix oscilloscope models, you might have to enable the socket server, which is a feature provided by TekVISA running on the instrument itself and can provide a raw TCP connection for instrument control.
- Use a third-party TCP/IP communication software, such as PuTTY, to check that you can access the specified IP address and port from other software.

Check Network Connection

Make sure that your network connection is configured properly.

- Make sure that your network adapter is enabled and connected.
- If the instrument has a built-in PC running the TCP socket server, check if a firewall on the instrument's PC is blocking communication.
- Check if a firewall on the client computer is blocking communication.
- Some instruments and servers (such as `tcpserver` objects) allow only one connection. Make sure that the instrument or server is not already connected to another client.

See Also

`tcpclient`

Related Examples

- “Troubleshooting TCP/IP Client Interface” on page 14-15

Resolve TCP/IP Client Warning: Unable to Read Any Data

Issue

These remedies apply when you receive no data and you get this warning message:

```
'tcpclient' unable to read any data
```

Possible Solutions

Try these remedies to resolve the following causes for when you use the TCP/IP client interface for:

- Reading ASCII (text) data using the `readline` function.
- Reading binary data using the `read` function.

Cause	Solution
An invalid command was sent to the device, so there is a problem reading the response to the command.	Check your device manual for proper command formatting.
An incorrect write terminator was sent to the instrument before attempting to read data, so there is no data to read.	Verify that the <code>Terminator</code> property is set to the value required by your device. For more information about setting the property, see <code>configureTerminator</code> .
Your device did not receive the command because the remote host address or the remote port is incorrect.	Verify that the device is at the remote host address that you specified, and is listening on the remote port that you specified when you created the <code>tcpclient</code> object. For more information about communication settings, see “Create TCP/IP Client and Configure Settings” on page 14-3 and “Write and Read Data over TCP/IP Interface” on page 14-7.

See Also

`configureTerminator` | `read` | `readline`

More About

- “Troubleshooting TCP/IP Client Interface” on page 14-15

Bluetooth Low Energy Communication

- “Bluetooth Low Energy Communication Overview” on page 15-2
- “Find Your Bluetooth Low Energy Peripheral Devices” on page 15-4
- “Work with Device Characteristics and Descriptors” on page 15-7
- “Collect Data from Fitness Monitoring Devices” on page 15-12
- “Track Orientation of Bluetooth Low Energy Device” on page 15-18
- “Troubleshooting Bluetooth Low Energy” on page 15-23

Bluetooth Low Energy Communication Overview

Bluetooth Low Energy is a wireless communication protocol for discovering and communicating with low-power peripheral devices. Bluetooth Low Energy support in MATLAB allows you to:

- Scan for nearby peripheral devices and view their advertisement data.
- Establish a connection between your computer and peripheral devices.
- Read and write characteristic and descriptor data.
- Subscribe to characteristics to enable notification or indication.

Bluetooth Low Energy Communication in MATLAB is different from “Bluetooth Communication” and the functionalities supported by “Bluetooth Toolbox”. To understand the use cases for each feature and to decide which one best fits your needs, refer to the documentation for each.

Prerequisites and Setup

To use the Bluetooth Low Energy interface in MATLAB, you need the following:

- A peripheral device that supports Bluetooth 4.0 or higher
- A built-in or external Bluetooth 4.0 adapter on your computer
- MATLAB installed on your computer

Make sure your computer has Bluetooth turned on. The peripheral device that you are scanning for must be near your computer and disconnected from other devices and applications.

Bluetooth Low Energy Concepts

The Bluetooth Low Energy communication is based on the Generic Access Profile (GAP) protocol for device discovery and the Generic Attribute (GATT) protocol for device communication. Both of these protocols are documented in detail on the Bluetooth SIG website. Although specific knowledge about GAP and GATT is not necessary to communicate with Bluetooth Low Energy devices in MATLAB, there are a few important concepts to understand.

During discovery, devices are either central devices or peripheral devices.

- A central device scans for advertisement data from other devices. In the Bluetooth Low Energy interface in MATLAB, your computer is always the central device.
- A peripheral device transmits advertisement data. Peripheral devices are nearby devices that you are scanning for. Peripheral devices include fitness trackers, health monitors, and personal electronics such as smartwatches or wireless headphones.

After discovering the peripheral devices, you can connect to multiple peripheral devices from MATLAB at the same time. For more information about scanning for and connecting to peripheral devices, see “Find Your Bluetooth Low Energy Peripheral Devices” on page 15-4.

After establishing a connection between MATLAB on your computer and a Bluetooth Low Energy peripheral device, the two have a client-server relationship. The server is the device that contains data, while the client is the device that receives the data and performs a function.

Services, Characteristics, and Descriptors

The building blocks of Bluetooth Low Energy device communication are services, characteristics, and descriptors. All three of these play a role in reading from and writing to peripheral devices in MATLAB. In peripheral devices, their functions are as follows:

- Services are collections of related characteristics. Services are not readable or writable, but the characteristics that they contain can be. For example, the Heart Rate service includes both the Heart Rate Measurement and Body Sensor Location characteristics.
- Characteristics contain values for user data or device data. This is the primary attribute of the peripheral device that you want to read. For example, the Heart Rate Measurement characteristic is a standard characteristic commonly found on fitness trackers. You can read or write characteristic values.
- Descriptors describe characteristic values. Each characteristic can have one or more descriptors associated with it. A descriptor contains metadata about the characteristic value being measured. For example, the Client Characteristic Configuration Descriptor is a descriptor that determines whether the device is currently collecting characteristic data or not. You can read or write descriptor values.

All three of these can be standard or custom. Standard services, characteristics, and descriptors are defined by the Bluetooth SIG, while custom services, characteristics, and descriptors are usually specific to the device or device manufacturer.

In the Bluetooth Low Energy interface in MATLAB, you can use `read` and `write` on `characteristic` and `descriptor` objects. You can also use `subscribe` and `unsubscribe` with `characteristic` objects. For more information about how to perform these operations, see “Work with Device Characteristics and Descriptors” on page 15-7.

See Also

`blelist` | `ble` | `characteristic` | `descriptor` | `read` | `write` | `subscribe` | `unsubscribe`

More About

- “Find Your Bluetooth Low Energy Peripheral Devices” on page 15-4
- “Work with Device Characteristics and Descriptors” on page 15-7
- “Collect Data from Fitness Monitoring Devices” on page 15-12
- “Track Orientation of Bluetooth Low Energy Device” on page 15-18
- “Troubleshooting Bluetooth Low Energy” on page 15-23

External Websites

- Bluetooth SIG

Find Your Bluetooth Low Energy Peripheral Devices

You can see a list of nearby Bluetooth Low Energy peripheral devices using `blelist`. After you identify your device on the list, you can establish a connection to it from MATLAB using `ble`.

Scan for Devices

Scan for Bluetooth Low Energy peripheral devices from MATLAB using `blelist`. This function lists all nearby peripheral devices that are advertising data. You can view the advertisement data for each device in MATLAB to determine whether it is connectable. If your device does not appear in the list, make sure it is powered on, nearby, and disconnected from any other devices or applications. Then scan for it again.

```
list = blelist
```

```
list=5x5 table
```

Index	Name	Address	RSSI	Advertisement
1	"Gear Fit2 (E16A)"	"8498663EE16A"	-54	[1x1 struct]
2	""	"2C4D2724754D"	-69	[1x1 struct]
3	""	"1B75E09FD18F"	-70	[1x1 struct]
4	""	"4F7D6DAF9FCE"	-75	[1x1 struct]
5	""	"7B8ADB5851BD"	-76	[1x1 struct]

Devices are sorted by RSSI, which represents signal strength. If there are several devices listed, use the `Name` field to identify your device.

The advertisement data for each device contains data defined in the Generic Access Profile (GAP) by Bluetooth SIG. The `Type` field in the advertisement data `Advertisement` shows the connection status. View advertisement data of the first device.

```
list.Advertisement(1)
```

```
ans = struct with fields:
```

```

    Type: ["Connectable Undirected" "Scan Response"]
    Appearance: "Generic Watch"
    ShortenedLocalName: []
    CompleteLocalName: "Gear Fit2 (E16A)"
    TxPowerLevel: []
    SlaveConnectionIntervalRange: []
    ManufacturerSpecificData: [0 117 1 0 2 0 1 3 0]
    ServiceData: []
    CompleteServiceUUIDs: []
    IncompleteServiceUUIDs: []
    ServiceSolicitationUUIDs: []

```

Scan for Devices by Name

You can use name-value pair arguments to list only devices with a particular name.

For example, list all peripheral devices with names starting with the string "UA".

```
list = blelist("Name", "UA")
```

```
list=2x5 table
  Index      Name                Address          RSSI  Advertisement
  -----
    1      "UA E39 MODULE"      "84DD20E39AB6"  -84   [1x1 struct]
    2      "UA Footpod 239AE2"  "0CF3EE239AE2"  -87   [1x1 struct]
```

You can use name-value pair arguments to scan for specific names when you have many peripheral devices nearby.

Scan for Devices by Service Name or UUID

For devices that are advertising services, you can use name-value pair arguments to list only devices with the specified service. Service name and service UUID are both valid.

For example, list all peripheral devices that advertise the `Heart Rate` service.

```
list = blelist("Services","Heart Rate")
```

```
list=1x5 table
  Index      Name                Address          RSSI  Advertisement
  -----
    1      "UA E39 MODULE"      "84DD20E39AB6"  -84   [1x1 struct]
```

You can use name-value pair arguments to scan for specific services when you know which services you want to work with.

Scan for Longer Time

You can increase the amount of time MATLAB scans for nearby devices. This is useful if your device has a high advertising interval and does not appear in the list with the default timeout value of three seconds.

```
list = blelist("Timeout",10);
```

Connect to a Device

After you discover your device, establish a connection between MATLAB and the peripheral device using `ble`. Specify the device name or address from the `blelist` output.

```
b = ble("Gear Fit2 (E16A)")
```

```
b =
  ble with properties:
      Name: "Gear Fit2 (E16A)"
      Address: "8498663EE16A"
      Connected: 1
      Services: [2x2 table]
      Characteristics: [3x5 table]
```

```
Show services and characteristics
```

After creating a connection to your device, you can work with the `Characteristics` listed in the `ble` properties. See “Work with Device Characteristics and Descriptors” on page 15-7 for more information and next steps.

See Also

blelist | ble

More About

- “Work with Device Characteristics and Descriptors” on page 15-7
- “Collect Data from Fitness Monitoring Devices” on page 15-12
- “Track Orientation of Bluetooth Low Energy Device” on page 15-18
- “Troubleshooting Bluetooth Low Energy” on page 15-23

Work with Device Characteristics and Descriptors

Before working with characteristics or descriptors, scan for and create a connection to your Bluetooth Low Energy peripheral device. See “Find Your Bluetooth Low Energy Peripheral Devices” on page 15-4 for more information and instructions. After connecting to your device, you can interface with it by reading or writing the device characteristics and descriptors.

```
b = ble("DemoDev");
```

Access Device Characteristics

View your device characteristics by looking at the `Characteristics` property of the `ble` object.

```
b.Characteristics
```

```
ans=11x5 table
      ServiceName                ServiceUUID                CharacteristicName
-----
"Generic Access"                "1800"                    "Device Name"
"Generic Access"                "1800"                    "Appearance"
"Generic Access"                "1800"                    "Peripheral Preferred Connection Parameters"
"Generic Access"                "1800"                    "Central Address Resolution List"
"Generic Attribute"            "1801"                    "Service Changed"
"Heart Rate"                    "180D"                    "Heart Rate Measurement"
"Heart Rate"                    "180D"                    "Body Sensor Location"
"Battery Service"               "180F"                    "Battery Level"
"User Data"                     "181C"                    "Gender"
"Custom"                        "03B80E5A-EDE8-4B33-A751-6CE34EC4C700" "Custom"
"Custom"                        "03B80E5A-EDE8-4B33-A751-6CE34EC4C700" "Custom"
```

This table lists each characteristic and the service it is associated with. As the table shows, each service can contain multiple characteristics. If multiple characteristics have the same name, differentiate between them using the UUID. In this example, the device has both standard and custom characteristics. Standard characteristics are defined by the Bluetooth SIG, while custom characteristics are usually specific to the device or device manufacturer.

The `Attributes` field in this table tells you the read and write permissions for each characteristic. Select a characteristic you are interested in and view its properties using `characteristic`. For example, access the "Gender" characteristic using the service and characteristic names.

```
c = characteristic(b, "User Data", "Gender")
```

```
c =
  Characteristic with properties:
      Name: "Gender"
      UUID: "2A8C"
      Attributes: "Read" "Write"
      Descriptors: []
```

This characteristic is both readable and writable.

Read and Write Characteristic Data

Because the "Gender" characteristic is readable and writable, you can write data to it and verify the change in values.

Use `read` to get the current data. The full behavior of `read` for a characteristic depends on the `Attributes` property, as described in `characteristicData`.

```
data = read(c)
```

```
data = 0
```

Interpret the data by referring to the specification for this characteristic on the Bluetooth SIG website. 0 represents male and 1 represents female. Write 1 to the characteristic to indicate female using `write`.

```
write(c,1)
```

You can read from the characteristic again to observe the change in the data.

```
data = read(c)
```

```
data = 1
```

Subscribe to Characteristic

You can also subscribe to a characteristic to enable notification or indication on the characteristic. You can only subscribe to characteristics that contain "Notify", "Indicate", or both in the `Attributes` property. After you enable notification or indication for a characteristic, use `read` to get the updated data. See `characteristicData` for a description of the full behavior of `read` based on `Attributes`.

For this example, create a characteristic object that represents the "Heart Rate Measurement" characteristic.

```
c = characteristic(b,"Heart Rate","Heart Rate Measurement")
```

```
c =  
  Characteristic with properties:  
      Name: "Heart Rate Measurement"  
      UUID: "2A37"  
      Attributes: "Notify"  
      Descriptors: [1x3 table]  
      DataAvailableFcn: []
```

```
Show descriptors
```

This characteristic supports "Notify".

Start receiving notifications by using `subscribe`. See `type` for a description of the full behavior of `subscribe` based on `Attributes`.

```
subscribe(c)
```

Read from the characteristic to check that you are receiving data.

```
read(c)
ans = 1×19
    23    14     1  187     1  186     1  185     1  184     1  183     1  182     1  181
```

Interpret the data by referring to the specification for this characteristic found in the Heart Rate Service on the Bluetooth SIG website.

After you finish working with the characteristic, disable notifications using `unsubscribe`.

```
unsubscribe(c)
```

Use Callback Function to Read Characteristic Data

You can also create a callback function to read characteristic data as it updates with new data from the device.

Because the "Heart Rate Measurement" characteristic supports "Notify", you can create a callback function called `displayCharacteristicData`. Specify the read mode as 'oldest' instead of 'latest'. Calling the 'latest' data can lead to errors in the callback function caused by the flushing of previous data.

```
function displayCharacteristicData(src,evt)
    [data,timestamp] = read(src,'oldest');
    disp(data);
    disp(timestamp);
end
```

Use the `@` operator to assign the function handle to the `DataAvailableFcn` property of the characteristic. When a new notification is available, the callback is called.

```
c.DataAvailableFcn = @displayCharacteristicData
```

```
c =
  Characteristic with properties:
        Name: "Heart Rate Measurement"
        UUID: "2A37"
    Attributes: "Notify"
    Descriptors: [1×3 table]
  DataAvailableFcn: displayCharacteristicData
```

```
Show descriptors
```

After you finish working with the characteristic, disable notifications and reset the callback using `unsubscribe`.

```
unsubscribe(c)
c.DataAvailableFcn = [];
```

Access Device Descriptors

If a characteristic has descriptors, you can access the descriptors to read from or write to them. View the descriptors for a characteristic by looking at the `Descriptors` property of the characteristic object.

For this example, show the `Descriptors` for the "Heart Rate Measurement" characteristic.

```
c.Descriptors
```

```
ans=1x3 table
```

DescriptorName	DescriptorUUID	Attributes
"Client Characteristic Configuration"	"2902"	{1x2 string}

Access the "Client Characteristic Configuration" descriptor.

```
d = descriptor(c,"Client Characteristic Configuration")
```

```
d =
```

```
Descriptor with properties:
```

```
    Name: "Client Characteristic Configuration"
    UUID: "2902"
Attributes: ["Read" "Write"]
```

This descriptor is both readable and writable.

Read and Write Descriptor Data

The "Client Characteristic Configuration" descriptor contains information about whether notification or indication is enabled or disabled. You can use `read` to get the current data.

```
data = read(d)
```

```
data = 1x2
```

```
    0    0
```

Interpret this data by referring to the specification for this descriptor found in the Bluetooth Core Specification found on the Bluetooth SIG website.

This value changes when the notification or indication status changes. For example, write to this value to enable notification for the "Heart Rate Measurement" characteristic using `write`. Then, observe the change in values by reading the descriptor again.

```
write(d,[1 0])
```

```
data = read(d)
```

```
data = 1x2
```

```
    1    0
```

See Also

[characteristic](#) | [descriptor](#) | [read](#) | [write](#) | [subscribe](#) | [unsubscribe](#)

More About

- “Find Your Bluetooth Low Energy Peripheral Devices” on page 15-4
- “Collect Data from Fitness Monitoring Devices” on page 15-12
- “Track Orientation of Bluetooth Low Energy Device” on page 15-18
- “Troubleshooting Bluetooth Low Energy” on page 15-23

Collect Data from Fitness Monitoring Devices

This example shows how to collect and plot data from fitness monitoring devices using Bluetooth® Low Energy communication.

Hardware Setup

This example uses an Under Armour® heart rate monitor belt and a pair of Under Armour smart running shoes. Both devices support Bluetooth Low Energy communication.

Discover and Connect to Devices

First, check that the Bluetooth Low Energy devices support connections by finding them in MATLAB®. The `blelist` function scans nearby Bluetooth Low Energy peripheral devices that are advertising.

```
blelist
```

```
ans=14x5 table
```

Index	Name	Address	RSSI	Advertisement
1	""	"21996E3A-8F31-496D-B332-79D03B759BC7"	-65	[1x1 struct]
2	""	"12377421-4EA3-4F77-9365-EFD580C34DE9"	-66	[1x1 struct]
3	"UA E39 MODULE"	"8206F662-BA4A-483F-A908-516FF506BFB0"	-67	[1x1 struct]
4	""	"CF65AD36-2146-4CA1-BCEA-FED47F6195CA"	-76	[1x1 struct]
5	"UA Footpod 239AE2"	"CF7B1A17-4104-4D7B-AE70-1837CAE9C9D0"	-78	[1x1 struct]
6	""	"67A1A92A-5F1C-4AF8-857A-99F194E9A5F8"	-82	[1x1 struct]
7	""	"5609D68D-0EED-41D7-BE19-F3ACAA119C7A"	-84	[1x1 struct]
8	""	"5A17DF46-6F71-4DAC-AF0D-0F28E3911187"	-85	[1x1 struct]
9	""	"9675A0FA-0394-468B-B908-040696E1C5BC"	-88	[1x1 struct]
10	""	"61540D17-C2DD-41D4-B107-E2E7374B11F4"	-88	[1x1 struct]
11	""	"C2A5CCC3-CA6C-4688-AAE9-A5BE039561F9"	-92	[1x1 struct]
12	""	"AF5E1195-4088-4A4B-ADA5-0BD3C91BFE62"	-93	[1x1 struct]
13	""	"83C69EFB-0FAD-4A35-B167-79C51A1F245D"	-94	[1x1 struct]
14	""	"993276FD-07EC-433D-85E1-E144B289B648"	-95	[1x1 struct]

After the devices are found in MATLAB, connect to them by calling `ble`. Specify the name of the device if the name is unique, or specify the device address.

```
belt = ble("UA E39 MODULE")
```

```
belt =
```

```
ble with properties:
```

```
    Name: "UA E39 MODULE"
    Address: "8206F662-BA4A-483F-A908-516FF506BFB0"
    Connected: 1
    Services: [4x2 table]
    Characteristics: [22x5 table]
```

```
Show services and characteristics
```

```
shoe = ble("UA Footpod 239AE2")
```

```

shoe =
  ble with properties:
      Name: "UA Footpod 239AE2"
      Address: "CF7B1A17-4104-4D7B-AE70-1837CAE9C9D0"
      Connected: 1
      Services: [8x2 table]
      Characteristics: [39x5 table]

```

Show services and characteristics

Access the Characteristics property of the `ble` object `belt`. This device has the "Heart Rate" service which contains the "Heart Rate Measurement" characteristic.

```
belt.Characteristics
```

```
ans=22x5 table
```

ServiceName	ServiceUUID	Characteristics
"Heart Rate"	"180D"	"Heart Rate Measurement"
"Heart Rate"	"180D"	"Body Sensor Location"
"Heart Rate"	"180D"	"Heart Rate Control Point"
"Battery Service"	"180F"	"Battery Level"
"Device Information"	"180A"	"System ID"
"Device Information"	"180A"	"Model Number String"
"Device Information"	"180A"	"Serial Number String"
"Device Information"	"180A"	"Firmware Revision String"
"Device Information"	"180A"	"Hardware Revision String"
"Device Information"	"180A"	"Software Revision String"
"Device Information"	"180A"	"Manufacturer Name String"
"Device Information"	"180A"	"IEEE 11073-20601 Regulator"
"Device Information"	"180A"	"PnP ID"
"Custom"	"21A51000-4C86-11E2-BCFD-0800200C9A66"	"Custom"
"Custom"	"21A51000-4C86-11E2-BCFD-0800200C9A66"	"Custom"
"Custom"	"21A51000-4C86-11E2-BCFD-0800200C9A66"	"Custom"
:		

Access the Characteristics property of the `ble` object `shoe`. This device has the "Running Speed and Cadence" service which contains the "RSC Measurement" characteristic.

```
shoe.Characteristics
```

```
ans=39x5 table
```

ServiceName	ServiceUUID	Characteristics
"Device Information"	"180A"	"System ID"
"Device Information"	"180A"	"Model Number String"
"Device Information"	"180A"	"Serial Number String"
"Device Information"	"180A"	"Firmware Revision String"
"Device Information"	"180A"	"Hardware Revision String"
"Device Information"	"180A"	"Software Revision String"
"Device Information"	"180A"	"Manufacturer Name String"
"Device Information"	"180A"	"IEEE 11073-20601 Regulator"
"Device Information"	"180A"	"PnP ID"
"Battery Service"	"180F"	"Battery Level"

```

"Running Speed and Cadence"    "1814"                "RSC Measurement"
"Running Speed and Cadence"    "1814"                "RSC Feature"
"Running Speed and Cadence"    "1814"                "SC Control Point"
"Custom"                       "21A54000-4C86-11E2-BCFD-0800200C9A66" "Custom"
"Custom"                       "21A54000-4C86-11E2-BCFD-0800200C9A66" "Custom"
"Custom"                       "21A54000-4C86-11E2-BCFD-0800200C9A66" "Custom"
:
```

Read Heart Rate Data

Next, create an object for the "Heart Rate Measurement" characteristic by specifying its service and characteristic information.

```
hr = characteristic(belt, "heart rate", "heart rate measurement")
```

```
hr =
  Characteristic with properties:
      Name: "Heart Rate Measurement"
      UUID: "2A37"
      Attributes: "Notify"
      Descriptors: [1x3 table]
      DataAvailableFcn: []
```

```
Show descriptors
```

Then read the current heart rate measurement from the device.

```
data = read(hr)
data = 1x4
      22      96      73      3
```

According to the Heart Rate Service specification in the Bluetooth Low Energy Specifications List, the "Heart Rate Measurement" characteristic value contains a flag byte followed by one or many heart rate values. The format of the measurement value depends on the flag value. Convert the raw data to a heart rate in beats per minute (bpm).

```
flag = uint8(data(1));
% Get the first bit of the flag, which indicates the format of the heart rate value
heartRateValueFormat = bitget(flag, 1);
if heartRateValueFormat == 0
    % Heart rate format is uint8
    heartRate = data(2);
else
    % Heart rate format is uint16
    heartRate = double(typecast(uint8(data(2:3)), 'uint16'));
end
fprintf('Heart rate measurement: %d(bpm)\n', heartRate);
Heart rate measurement: 96(bpm)
```

Read Running Speed and Cadence Data

Similarly, create an object for the "RSC Measurement" characteristic by specifying its service and characteristic information.

```
rsc = characteristic(shoe, "running speed and cadence", "rsc measurement")
```

```
rsc =
  Characteristic with properties:
      Name: "RSC Measurement"
      UUID: "2A53"
      Attributes: "Notify"
      Descriptors: [1x3 table]
      DataAvailableFcn: []
```

```
Show descriptors
```

Then read the current running speed and cadence value from the device.

```
data = read(rsc)
```

```
data = 1x10
```

```
    3    0    0    0    0    0    84    57    0    0
```

According to the Running Speed and Cadence Service specification in the Bluetooth Low Energy Specifications List, the "RSC Measurement" characteristic value contains 2 bytes that represents the instantaneous speed and 1 byte that represents the instantaneous cadence. Convert the raw data to a running speed in meters per second (m/s) and to a cadence in steps per minute.

```
instantaneousSpeed = double(typecast(uint8(data(2:3)), 'uint16'))/256;
```

```
instantaneousCadence = data(4);
```

```
fprintf('Instantaneous speed: %.2f(m/s) and instantaneous cadence: %d(steps per minute)\n', inst
```

```
Instantaneous speed: 0.00(m/s) and instantaneous cadence: 0(steps per minute)
```

Correlate Heart Rate and Running Speed

After reading the heart rate and RSC data, track live data during a running session and correlate the two measurements to analyze fitness performance.

To show the correlation of fitness data, first create two plots to create an animation by adding data points in a loop.

```
% Create a plot for running speed against heart rate
```

```
axSpeed = axes('XLim', [0, 5], 'YLim', [60, 220]);
```

```
xlabel(axSpeed, 'Running speed (m/s)');
```

```
ylabel(axSpeed, 'Heart rate (bpm)');
```

```
subplot(1, 2, 1, axSpeed);
```

```
hSpeed = animatedline(axSpeed, 'Marker', 'o', 'MarkerFaceColor', 'green');
```

```
% Create a plot for running cadence against heart rate
```

```
axCadence = axes('XLim', [0, 200], 'YLim', [60 220]);
```

```
xlabel(axCadence, 'Running cadence (steps per minute)');
```

```
ylabel(axCadence, 'Heart rate (bpm)');
```

```
subplot(1, 2, 2, axCadence);
hCadence = animatedline(axCadence, 'Marker', 'o', 'MarkerFaceColor', 'blue');
```

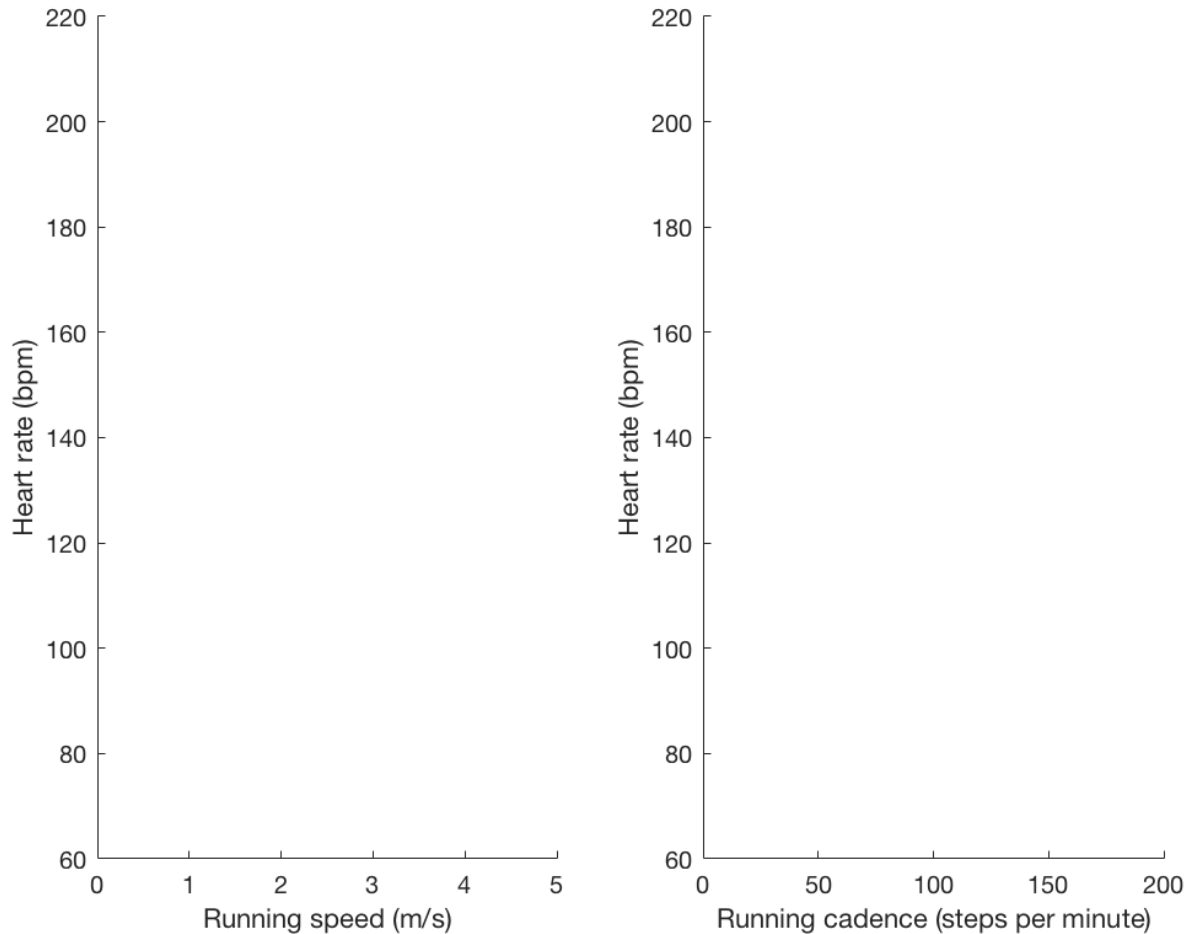

Next, read device data in a loop and update the plot as the user progresses from walking to jogging to running.

```
for loop = 1:30
    % Get heart rate data
    data = read(hr);
    flag = uint8(data(1));
    heartRateValueFormat = bitget(flag, 1);
    if heartRateValueFormat == 0
        heartRate = data(2);
    else
        heartRate = double(typecast(uint8(data(2:3)), 'uint16'));
    end

    % Get running speed data
    data = read(rsc);
    instantaneousSpeed = double(typecast(uint8(data(2:3)), 'uint16'))/256;
    instantaneousCadence = data(4);
```

```

% Update plot with new data
addpoints(hSpeed, instantaneousSpeed, heartRate);
addpoints(hCadence, instantaneousCadence, heartRate);
drawnow;
end

```

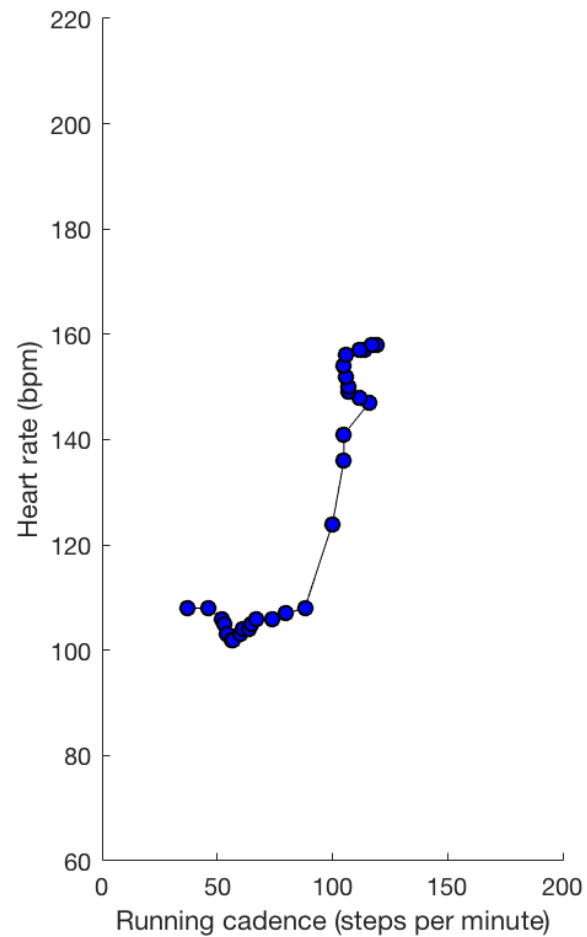
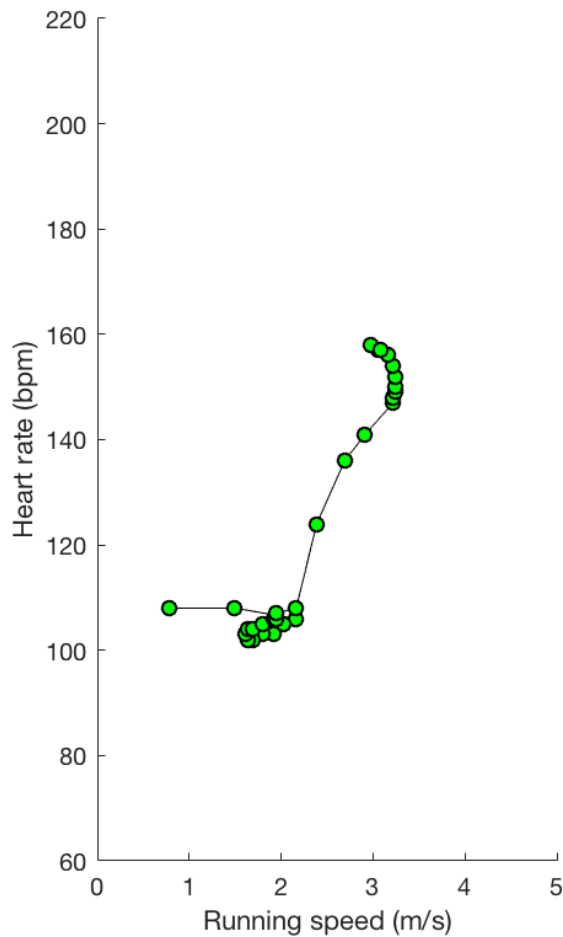

These plots generally show that higher running speed and cadence values correspond to an increased heart rate.

Disconnect from Device

Clear the device objects when you are finished working with them.

```
clear belt shoe
```

Track Orientation of Bluetooth Low Energy Device

This example shows how to track device orientation with device motion sensor data using Bluetooth® Low Energy communication.

Hardware Setup

This example uses the Nordic Thingy:52™ device. Nordic Thingy:52 is a Bluetooth Low Energy device with a 9-axis motion sensor. This device provides a rich set of sensor data including raw accelerometer, gyroscope, compass, and fused data. This example uses the device calculated rotation matrix to track the device orientation.

Discover and Connect to Device

First, check that the Bluetooth Low Energy device supports connections by finding it in MATLAB®. The `blelist` function scans nearby Bluetooth Low Energy peripheral devices that are advertising.

```
blelist
```

```
ans=20x5 table
```

Index	Name	Address	RSSI	Advertisement
1	"Thingy"	"F2DF635320F6"	-54	[1x1 struct]
2	" "	"5AE98748DC34"	-73	[1x1 struct]
3	" "	"7A9762B423E0"	-76	[1x1 struct]
4	" "	"5E0EAEF93E78"	-76	[1x1 struct]
5	" "	"08534F9CC17B"	-77	[1x1 struct]
6	" "	"4323693660AC"	-79	[1x1 struct]
7	" "	"5386B1B9FCEC"	-82	[1x1 struct]
8	" "	"2D132D3ACD33"	-83	[1x1 struct]
9	" "	"537E555A0188"	-84	[1x1 struct]
10	" "	"237E6384E9BF"	-87	[1x1 struct]
11	" "	"2C0CA5F4793C"	-88	[1x1 struct]
12	" "	"55D810EF7331"	-89	[1x1 struct]
13	" "	"3A01FA8D3D18"	-89	[1x1 struct]
14	" "	"2084C6A7DA4D"	-90	[1x1 struct]
15	" "	"52DBAB89F58F"	-91	[1x1 struct]
16	" "	"528E12038BD6"	-91	[1x1 struct]
:				

After the device is found in MATLAB, connect to it by calling `ble`. Specify the name of the device if it has a unique name, or specify the device address.

```
b = ble("Thingy")
```

```
b =
```

```
ble with properties:
```

```

    Name: "Thingy"
    Address: "F2DF635320F6"
    Connected: 1
    Services: [9x2 table]
    Characteristics: [38x5 table]
```

```
Show services and characteristics
```

Access the Characteristics property of the `ble` object. The device has the "Motion Service" service, which contains the "Rotation Matrix" characteristic.

b.Characteristics

ans=38x5 table

ServiceName	ServiceUUID	Char
"Generic Access"	"1800"	"Device Name"
"Generic Access"	"1800"	"Appearance"
"Generic Access"	"1800"	"Peripheral Prefe"
"Generic Access"	"1800"	"Central Address"
"Generic Attribute"	"1801"	"Service Changed"
"Thingy Configuration Service"	"EF680100-9B35-4933-9B10-52FFA9740042"	"Device Name"
"Thingy Configuration Service"	"EF680100-9B35-4933-9B10-52FFA9740042"	"Advertising Para"
"Thingy Configuration Service"	"EF680100-9B35-4933-9B10-52FFA9740042"	"Connection Para"
"Thingy Configuration Service"	"EF680100-9B35-4933-9B10-52FFA9740042"	"Eddystone URL"
"Thingy Configuration Service"	"EF680100-9B35-4933-9B10-52FFA9740042"	"Cloud Token"
"Thingy Configuration Service"	"EF680100-9B35-4933-9B10-52FFA9740042"	"Firmware Versio"
"Thingy Configuration Service"	"EF680100-9B35-4933-9B10-52FFA9740042"	"MTU Request"
"Thingy Configuration Service"	"EF680100-9B35-4933-9B10-52FFA9740042"	"NFC Tag Content"
"Weather Station Service"	"EF680200-9B35-4933-9B10-52FFA9740042"	"Temperature"
"Weather Station Service"	"EF680200-9B35-4933-9B10-52FFA9740042"	"Pressure"
"Weather Station Service"	"EF680200-9B35-4933-9B10-52FFA9740042"	"Humidity"
:		

Read Sensor Data

Next, create an object for the "Rotation Matrix" characteristic by specifying its service and characteristic information.

```
c = characteristic(b, "motion service", "rotation matrix")
```

```
c =
```

```
Characteristic with properties:
```

```
    Name: "Rotation Matrix"
    UUID: "EF680408-9B35-4933-9B10-52FFA9740042"
    Attributes: "Notify"
    Descriptors: [1x3 table]
    DataAvailableFcn: []
```

```
Show descriptors
```

Then read the current rotation matrix value from the device.

```
data = read(c)
```

```
data = 1x18
```

```
    253    63    255    255    15     1    255    255     0    64     8     0    240    254    247    255
```

According to the Nordic Thingy:52 documentation, this raw data contains a 3-by-3 matrix where each element is a 16-bit integer sent in 2 bytes. Each element represents a signed floating point number,

composed of 2 sign-and-exponent bits and 14 fraction bits. Interpret the raw data as a rotation matrix.

```
% Prepare 4-by-4 transform matrix to plot later (assume the device has no
% translation and only rotation)
transformMatrix = eye(4);
% Populate the transform matrix with 9 rotation matrix elements
for row = 1:3
    for column = 1:3
        % Extract the 2 bytes representing the current element in the rotation matrix
        beginIndex = (row-1)*3 + (column-1);
        element = data(2*beginIndex + (1:2));
        transformMatrix(row, column) = double(typecast(uint8(element), 'int16')) / (2^14);
    end
end
% Display the transform matrix
disp(transformMatrix);

    0.9998    -0.0001    0.0165         0
   -0.0001    1.0000    0.0005         0
   -0.0166   -0.0005    0.9998         0
         0         0         0         1.0000
```

Track Device Orientation

To show live tracking of the device orientation, first plot a 3-D object representing the Nordic Thingy:52 device.

```
% Create a 3-D plot
ax = axes('XLim', [-1.5 1.5], 'YLim', [-1.5 1.5], 'ZLim', [-1 2]);
xlabel(ax, 'X-axis');
ylabel(ax, 'Y-axis');
zlabel(ax, 'Z-axis');
% Reverse the 2 axis directions to match the device coordinate system
set(ax, 'Zdir', 'reverse');
set(ax, 'Xdir', 'reverse');
grid on; view(3);

% Define the surface color
color = [0.3010 0.7450 0.9330];

% Create patches for all cube surfaces by specifying the four corners of each surface
top = [-1 -1 1; 1 -1 1; 1 1 1; -1 1 1];
p(1) = patch(top(:,1), top(:,2), top(:,3), color);

bottom = [-1 -1 0; 1 -1 0; 1 1 0; -1 1 0];
p(2) = patch(bottom(:,1), bottom(:,2), bottom(:,3), color);

front = [1 -1 0; 1 1 0; 1 1 1; 1 -1 1];
p(3) = patch(front(:,1), front(:,2), front(:,3), color);

back = [-1 -1 0; -1 1 0; -1 1 1; -1 -1 1];
p(4) = patch(back(:,1), back(:,2), back(:,3), color);

left = [1 -1 0; -1 -1 0; -1 -1 1; 1 -1 1];
p(5) = patch(left(:,1), left(:,2), left(:,3), color);

right = [1 1 0; -1 1 0; -1 1 1; 1 1 1];
```

```
p(6) = patch(right(:,1), right(:,2), right(:,3), color);

mark = [0.9 -0.7 -0.01; 0.7 -0.7 -0.01; 0.7 -0.9 -0.01; 0.9 -0.9 -0.01];
p(7) = patch(mark(:,1), mark(:,2), mark(:,3), 'black');

% Set the object transparency
alpha(0.5)
```

After the 3-D object is created, link the rotation matrix data acquired from the device to the plot by using `hgtransform`.

```
tfObject = hgtransform('Parent', ax);
set(p, 'Parent', tfObject);
```

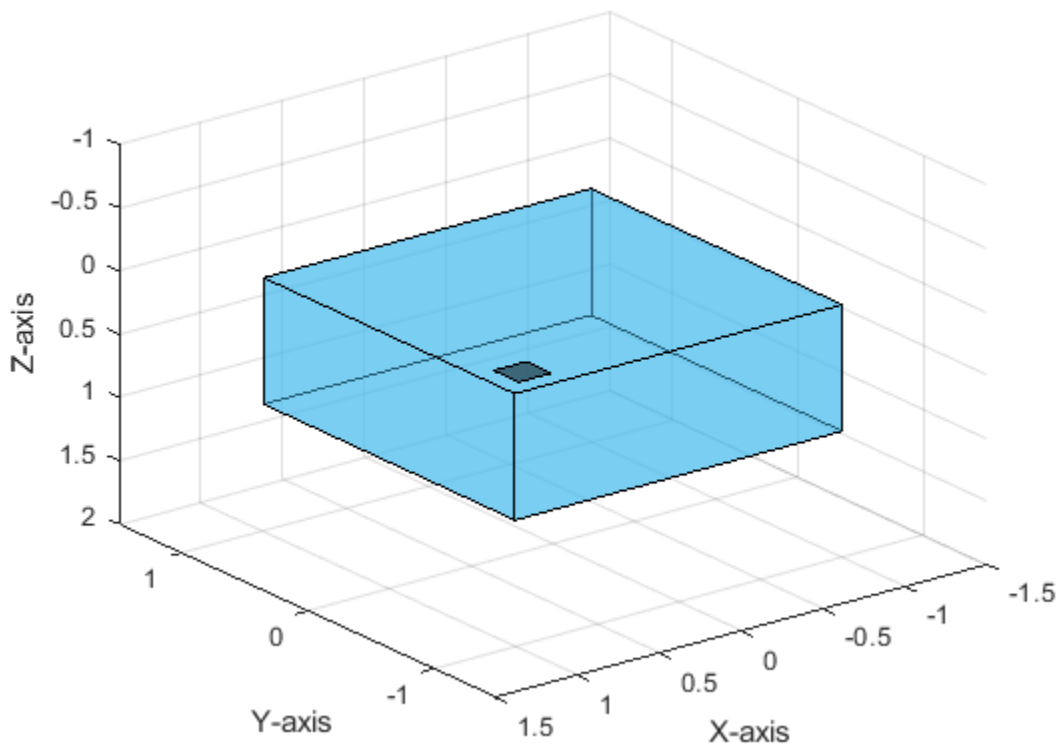

With the Transform object, pull device data in a loop and use the data to update the object orientation. The rotation matrix data sent from the device has precision loss, which can cause matrix transformation warnings. For this example, ignore the warning by suppressing it. For greater accuracy, you can use "Euler" or "Quaternion" characteristic data and convert it to a rotation matrix using Robotics System Toolbox™.

```
warning('off', 'MATLAB:hg:DiceyTransformMatrix');
for loop = 1:100
    % Acquire device data
    data = read(c);
    % Prepare 4-by-4 transform matrix to plot later
    transformMatrix = eye(4);
    % Populate the transform matrix with 9 rotation matrix elements
```

```

for row = 1:3
    for column = 1:3
        % Extract the 2 bytes representing the current element in the rotation matrix
        beginIndex = (row-1)*3 + (column-1);
        element = data(2*beginIndex + (1:2));
        transformMatrix(row, column) = double(typecast(uint8(element), 'int16')) / (2^14);
    end
end

% Update plot
set(tfObject, 'Matrix', transformMatrix);
pause(0.1);
end

```

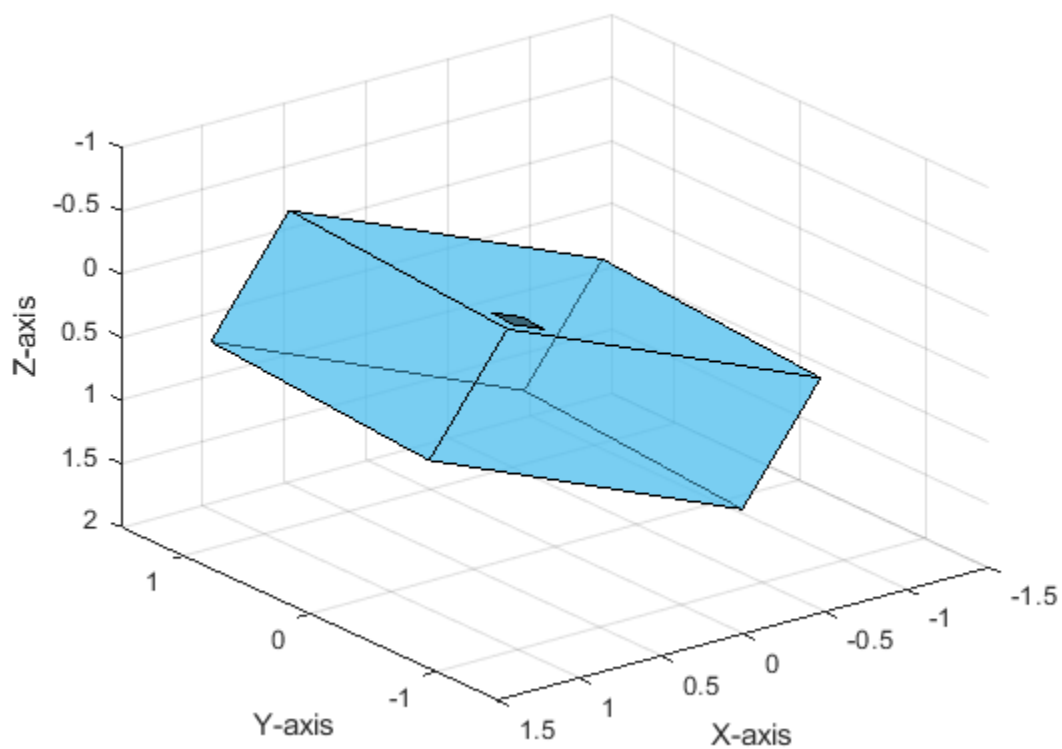

```
warning('on', 'MATLAB:hg:DiceyTransformMatrix');
```

Close Device Connection

Clear the device object when you are finished working with it.

```
clear b
```

Troubleshooting Bluetooth Low Energy

Issue

If you are having issues connecting to your Bluetooth Low Energy peripheral device from MATLAB or are unable to read or write data, you can try some of the following troubleshooting tips.

Possible Solutions

Check Supported Platforms

The Bluetooth Low Energy interface is supported on these platforms:

- macOS 10.13 High Sierra or later
- Windows 10, version 1709 or later

Before trying other troubleshooting steps, make sure your computer is running one of these platforms.

Configure Adapter

If MATLAB does not detect your built-in or external Bluetooth adapter when you call `blelist`, try the following:

- Make sure the adapter supports Bluetooth 4.0 and higher.
- Restart Bluetooth services on your computer.
- Update to the latest device drivers for your adapter.
- Reboot your computer.

Check Device Status

If your device does not appear in the `blelist` output, make sure that you have done the following:

- Power on your peripheral device.
- Bring your peripheral device within range of your computer.
- Disconnect your peripheral device from any other devices or applications first. The output from `blelist` shows you only nearby devices that are currently advertising data. If your device is already connected in another application or in MATLAB, it might not appear in the output.
- Try a larger value for the `Timeout` parameter in `blelist`. This increases the amount of time MATLAB scans for nearby devices. For example, `blelist("Timeout",20)` searches for nearby peripheral devices for 20 seconds. The default timeout value is three seconds. If your device transmits advertisement data less often than once every three seconds, MATLAB might not capture it.

If your peripheral device powers off or disconnects, the UUID might change when it powers on again or reconnects. However, the name remains the same in the `blelist` output. If you are trying to create a new `ble` object for the same device, specify the new UUID instead of the name.

On Windows, if a peripheral device has already been paired but the firmware that defines characteristics and descriptors is changed, `ble` might fail to connect the device to your computer. To fix this, disconnect and then reconnect your device to Windows.

If you are unable to create a `characteristic` object for your Bluetooth Low Energy device on Windows 10, try pairing your device on Windows before using `ble` to connect to it in MATLAB. You can pair to a device in **Windows Settings > Devices > Add Bluetooth or other device**.

Enable Bluetooth Permissions on macOS Big Sur

If you are using macOS Big Sur, you may need to configure additional settings. Try the following steps when you get this error message:

Bluetooth permission is not enabled for MATLAB. Allow MATLAB or Terminal to use Bluetooth from the Security & Privacy settings.

Open **Security & Privacy > Privacy > Bluetooth** and click the **+** icon.

- If you launch MATLAB from **Applications**, add MATLAB to the list of apps that are allowed Bluetooth access.
- If you launch MATLAB from **Terminal**, add **Terminal** to the list of apps that are allowed Bluetooth access.
- If you launch MATLAB from both **Applications** and **Terminal**, add both MATLAB and **Terminal** to the list of apps that are allowed Bluetooth access.

Troubleshoot Read and Write Operations

Using `read(c, 'latest')` or `read(c)` inside a callback function for a characteristic with a high rate can throw an error or block MATLAB for a long time. Instead, use `read(c, 'oldest')` in a callback function. For an example, see “Read Characteristic Data from a Bluetooth Low Energy Peripheral Device Using a Callback Function”.

On macOS, some device characteristics require authentication to read or write for the first time. After you create a `ble` object, run `read` or `write`. Follow the prompts that appear on your computer to pair your peripheral device.

See Also

`blelist` | `ble` | `characteristic` | `descriptor`

More About

- “Bluetooth Low Energy Communication Overview” on page 15-2
- “Find Your Bluetooth Low Energy Peripheral Devices” on page 15-4
- “Work with Device Characteristics and Descriptors” on page 15-7

Bluetooth Communication

- “Bluetooth Communication Overview” on page 16-2
- “Configure Bluetooth Communication Settings” on page 16-3
- “Transmit Data Using Bluetooth Communication” on page 16-6
- “Use Callbacks for Bluetooth Communication” on page 16-8
- “Troubleshooting Bluetooth Communication” on page 16-10
- “Resolve Bluetooth Connection Errors” on page 16-12
- “Resolve Bluetooth Warning: Unable to Read Any Data” on page 16-14
- “Resolve Bluetooth Warning: Unable to Read All Data” on page 16-15
- “Communicate with HC-06 over Bluetooth” on page 16-16
- “Transition Your Code to bluetooth Interface” on page 16-19

Bluetooth Communication Overview

Bluetooth Communication

The Bluetooth interface in MATLAB allows you to connect to devices over the Bluetooth communication protocol and to transmit and receive ASCII and binary data. MATLAB supports the Bluetooth Serial Port Profile (SPP). You can identify any SPP Bluetooth device and establish a two-way connection with that device.

Bluetooth is an open wireless technology standard for exchanging data over short distances by short wavelength radio transmissions from fixed and mobile devices using a packet-based protocol. Bluetooth provides a secure way to connect and exchange information between devices such as LEGO® MINDSTORMS® NXT robots, USB Bluetooth adapters (dongles), wireless sensors, mobile phones, and computers.

Specifications about the Bluetooth standard can be found at the Bluetooth SIG website.

Support for Bluetooth communication in MATLAB is different from “Bluetooth Low Energy Communication” and the functionalities supported by “Bluetooth Toolbox”. To understand the use cases for each feature and to decide which one best fits your needs, refer to the documentation for each.

Supported Platforms

The Bluetooth interface is supported on these platforms:

- macOS 10.14 Mojave or later
- Windows 10

See Also

`bluetoothlist` | `bluetooth`

More About

- “Configure Bluetooth Communication Settings” on page 16-3
- “Transmit Data Using Bluetooth Communication” on page 16-6
- “Use Callbacks for Bluetooth Communication” on page 16-8

Configure Bluetooth Communication Settings

Discover Your Device

To connect to a Bluetooth device from MATLAB, your computer needs to have a built-in or external Bluetooth adapter. The adapter identifies Bluetooth devices within range when queried. After identifying nearby devices in the Bluetooth settings on your computer, you need to pair your device with your computer first before connecting to it from MATLAB.

On Windows, you can pair to a device in **Settings > Devices > Add Bluetooth or other device**. The following shows the Windows Bluetooth settings where two of the devices in range have been paired—an audio device named E7 and a phone named Pixel 3. These are the same names you see in the `bluetoothlist` output.

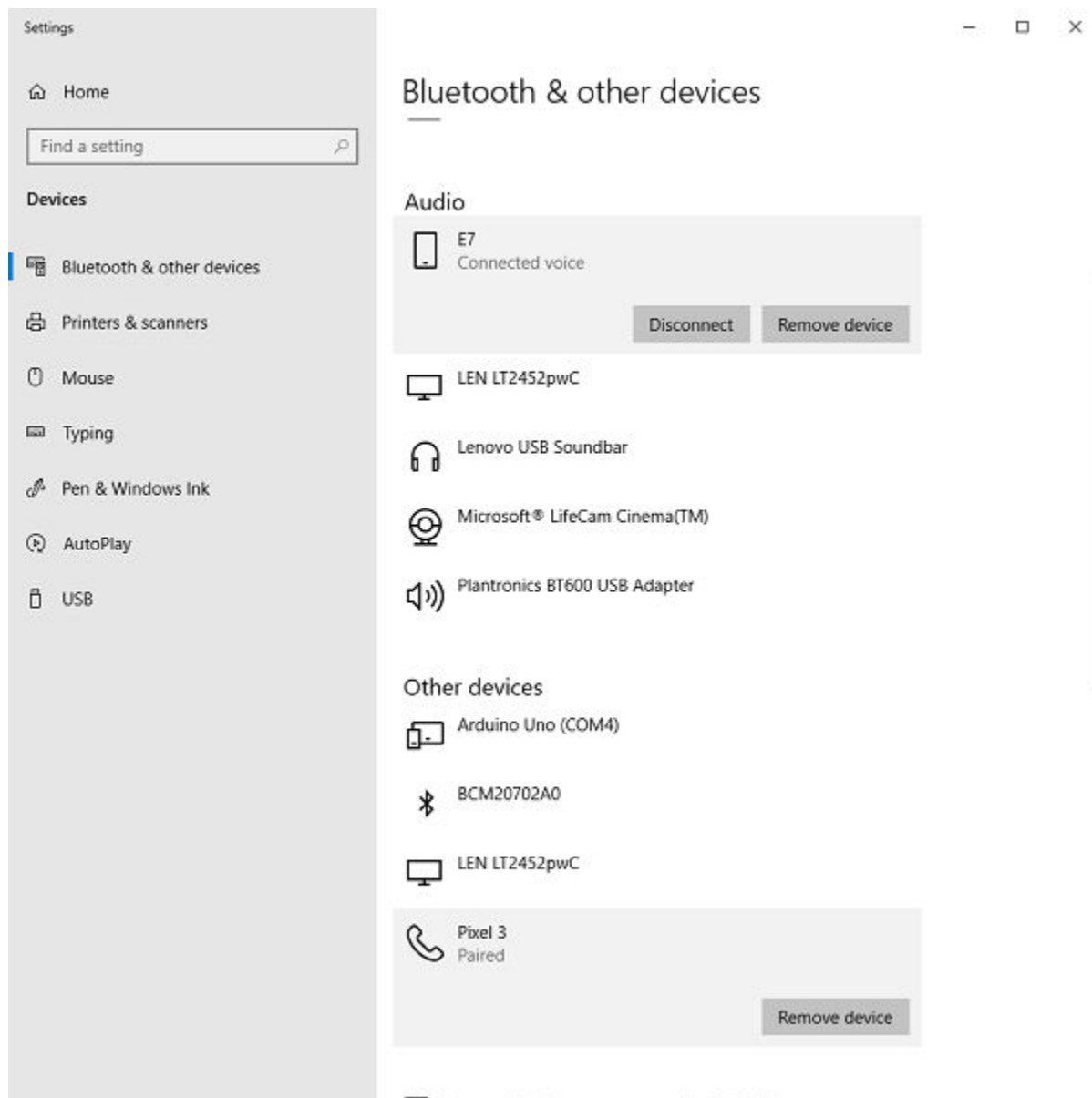

Use `bluetoothlist` to see a list of nearby Bluetooth devices and their connection statuses.

```
bluetoothlist
```

```
ans =
```

```
4×4 table
```

Name	Address	Channel	Status
"E7"	"FC58FA8156E8"	1	"Ready to connect"
"Pixel 3"	"3C286DD533CA"	8	"Ready to connect"
"	"98D331FB3B77"	Unknown	"Unknown"
"mjin-maci"	"A886DDA44062"	Unknown	"Unknown"

`bluetoothlist` returns a table of four Bluetooth devices that are in the range of the adapter on the computer. You can see that both E7 and Pixel 3 are shown in the list and have the status "Ready to connect". You can connect to a Bluetooth device using `bluetooth` only if its status is "Ready to connect". For a complete list of possible statuses, see "Status".

Connect to Your Device and View Properties

You can use `bluetooth` to connect to a device with either the name or address displayed in the output of `bluetoothlist`. If a device shows an empty string as its name, you must connect to it using its address. To successfully connect to your device, you must specify the same channel that appears in the output of `bluetoothlist`. If you do not specify the channel when you connect to a device, MATLAB attempts to connect to the default channel 1.

This example looks at the Pixel 3 phone in the previous section. The `bluetoothlist` output provides the information you need to create a `bluetooth` object for this device. You must specify either the name or address and the channel.

```
device = bluetooth("Pixel 3",8)
```

```
device =
```

```
bluetooth with properties:
```

```

    Name: "Pixel 3"
    Address: "3C286DD533CA"
    Channel: 8
    NumBytesAvailable: 0
    NumBytesWritten: 0
```

```
Show all properties
```

Click `properties` to view a full list of properties and their values for the `bluetooth` object `device`.

```

    Name: "Pixel 3"
    Address: "3C286DD533CA"
    Channel: 8
    NumBytesAvailable: 0
    NumBytesWritten: 0
```

```
        ByteOrder: "little-endian"  
        Timeout: 10  
        Terminator: "LF"  
  
        BytesAvailableFcn: []  
BytesAvailableFcnCount: 64  
        BytesAvailableFcnMode: "off"  
  
        ErrorOccurredFcn: []  
        UserData: []
```

See Also

`bluetoothlist` | `bluetooth`

More About

- “Transmit Data Using Bluetooth Communication” on page 16-6

Transmit Data Using Bluetooth Communication

You can read and write both text data (ASCII based) and binary data. For text data, use the `readline` and `writeline` functions. For binary data, use the `read` and `write` functions.

In this example, a LEGO MINDSTORMS NXT robot with the name C3P0 is connected to the computer. Communicate with the NXT device by following these steps.

- 1 Determine what Bluetooth devices are accessible from your computer.

```
bluetoothlist
```

```
ans =
```

```
4x4 table
```

Name	Address	Channel	Status
"C3P0"	"0016530FD63D"	1	"Ready to connect"
"HC-06"	"98D331FB3B77"	1	"Requires pairing"
"mj-in-maci"	"A886DDA44062"	3	"Requires pairing"
"DMTDevice"	"B0B448F47A4C"	Unknown	"Unknown"

- 2 In this case, C3P0 is the device name of the NXT robot and is shown in the output. To connect to the device, create a Bluetooth object called `bt` using channel 1 of the NXT device.

```
bt = bluetooth("C3P0",1);
```

```
bt =
```

```
bluetooth with properties:
```

```

    Name: "C3P0"
    Address: "0016530FD63D"
    Channel: 1
    NumBytesAvailable: 0
    NumBytesWritten: 0

```

```
Show all properties
```

- 3 Send a message to the remote device using the `write` function. In this example, specific characters are sent to the device that this particular device (the NXT robot C3P0) understands. You can write to the device and then view the `NumBytesWritten` property to check that the values were sent.

```
write(bt,[2,0,1,155])
bt.NumBytesWritten
```

```
ans =
```

```
35
```

You can see that the 35 bytes of data have been written to the device.

- 4 View the `NumBytesAvailable` property to see the number of bytes available to read.

```
bt.NumBytesAvailable
```

```
ans =
```

```
    35
```

Use the `read` function to read 35 bytes from the remote device.

```
name = read(bt,35);
char(name(7:10))
```

```
ans =
```

```
    'C3P0'
```

The device returns the characters `'C3P0'`, which is the name of the device. That was a reply to the instructions that were sent to it. See the documentation for your device for this type of device-specific communication information.

- 5 Clean up by clearing the object.

```
clear bt
```

Other Functionality

The following functions can be used with the Bluetooth object.

<code>read</code>	Read data from Bluetooth device
<code>readline</code>	Read line of ASCII string data from Bluetooth device
<code>write</code>	Write data to Bluetooth device
<code>writeline</code>	Write line of ASCII data to Bluetooth device
<code>configureTerminator</code>	Set terminator for ASCII string communication with Bluetooth device
<code>configureCallback</code>	Set callback function and trigger condition for communication with Bluetooth device
<code>flush</code>	Clear Bluetooth device buffers

See Also

`bluetoothlist` | `bluetooth`

More About

- “Configure Bluetooth Communication Settings” on page 16-3
- “Use Callbacks for Bluetooth Communication” on page 16-8

Use Callbacks for Bluetooth Communication

You can enhance the power and flexibility of your Bluetooth device by using events and callbacks. An event occurs after a condition is met and can result in one or more callbacks.

While MATLAB is connected to a Bluetooth device, you can use events to display a message, display data, analyze data, and so on. You can control callbacks through callback properties and callback functions. All event types have an associated callback property. Callback functions are MATLAB functions that you write to suit your specific application needs. Execute a callback when a particular event occurs by specifying the name of the callback function as the value for the associated callback property.

Callback Properties

The Bluetooth properties and functions associated with callbacks follow.

Property or Function	Purpose
NumBytesAvailable	Number of bytes available to read
BytesAvailableFcn	Bytes available callback function
BytesAvailableFcnCount	Number of bytes of data to trigger callback
BytesAvailableFcnMode	Bytes available callback trigger mode
configureCallback	Set callback function and trigger condition for communication with Bluetooth device
ErrorOccurredFcn	Callback function triggered by error event
UserData	General purpose property for user data

Using Callbacks

This example uses a HC-06 Bluetooth transceiver module configured as a loopback device.

- 1 Create the callback function. Define a callback function `collectData` that reads received data and stores it in the `UserData` property of the `bluetooth` object.

```
function collectData(src,evt)
    src.UserData = [src.UserData; read(src,src.BytesAvailableFcnCount)];
end
```

- 2 Create a `bluetooth` object `hc06` for the HC-06 module.

```
hc06 = bluetooth("HC-06",1)

hc06 =
    bluetooth with properties:
        Name: "HC-06"
        Address: "98D331FB3B77"
        Channel: 1
        NumBytesAvailable: 0
        NumBytesWritten: 0

Show all properties
```

- 3 Configure callback properties to read and collect data each time five bytes are sent by the device and received in MATLAB.

```
configureCallback(hc06,"byte",5,@collectData);
```

- 4 Clear the bluetooth device object when you are done working with it.

```
clear hc06
```

See Also

[bluetooth](#) | [configureCallback](#) | [read](#)

More About

- “Configure Bluetooth Communication Settings” on page 16-3

Troubleshooting Bluetooth Communication

The MATLAB Bluetooth interface allows you to connect to devices over Bluetooth and to transmit and receive ASCII and binary data. MATLAB supports the Bluetooth Serial Port Profile (SPP). You can identify any SPP Bluetooth device and establish a two-way connection with that device.

Issue

If you are having trouble discovering your Bluetooth devices, connecting to them, or communicating with them, try these troubleshooting tips.

Possible Solutions

Check Supported Platforms

The Bluetooth interface is supported on these platforms:

- macOS 10.14 Mojave or later
- Windows 10

Configure Adapter

To connect to Bluetooth devices from MATLAB, your computer needs to have a built-in or external Bluetooth adapter. The adapter identifies Bluetooth devices within range when queried. After identifying nearby devices in the Bluetooth settings on your computer, you need to pair your device with your computer first before connecting to it from MATLAB. For more information about discovering and pairing your device, see “Configure Bluetooth Communication Settings” on page 16-3.

If a Bluetooth adapter is removed and a different one plugged in, all Bluetooth devices have to be paired again with your computer. If the same adapter is removed and plugged back in, then you do not need to pair the devices again.

If MATLAB does not detect your built-in or external adapter, restart Bluetooth services on your computer and update to the latest device drivers for your adapter. Then, restart your computer.

Check Device Status

Make sure that the Bluetooth device is turned on and that the Bluetooth service on the device is turned on. Bring the device within range of your computer.

View the status of your device in MATLAB by using the `bluetoothlist` function. You can connect to a device using `bluetooth` only if its status is "Ready to connect". Possible status values follow.

Value	Description
"Ready to connect"	Device supports SPP, is paired, and is not connected anywhere.
"Requires pairing"	Device supports SPP and is not paired.
"Connected"	Device supports SPP and is connected.

Value	Description
"Unsupported"	Device does not support SPP.
"Unknown"	Unknown if device supports SPP. Device is turned off or fails to respond to scanning request.

If your device status is "Unsupported", it does not support SPP. You cannot connect to it from MATLAB.

If your device status is "Unknown", it fails to respond to a scanning request. Make sure that it is within range, turned on, and not already connected outside MATLAB.

If your device does not appear in the `bluetoothlist` output, make sure that it is not connected to any other devices or applications. You can also try a larger value for the `Timeout` parameter in `bluetoothlist`. Using a larger value increases the amount of time MATLAB scans for nearby devices.

For more information about connecting to your device, see "Configure Bluetooth Communication Settings" on page 16-3.

Check Device Connection

Make sure you can connect to the device by creating a `bluetooth` object. You must provide two arguments to create the object, either the device name or address and a channel number. The specified channel number must match the channel number from the `bluetoothlist` output. For more information about creating a `bluetooth` object, see `bluetooth`.

After you connect to the device, you can communicate with it. For more information about communicating with your device, see "Transmit Data Using Bluetooth Communication" on page 16-6.

Device Out of Range

If you create a `bluetooth` object for a Bluetooth device and the device goes out of range, the object still exists in the MATLAB workspace. However, when the device comes into range again, you must clear the object and create it again for communication to continue.

Make Sure Device Is Powered On

If you create a `bluetooth` object for a Bluetooth device and the device is turned off or runs out of charge, the object still exists in the MATLAB workspace. However, if you recharge and turn on the device again, you must clear the object and create it again for communication to continue.

See Also

`bluetooth`

Related Examples

- "Resolve Bluetooth Connection Errors" on page 16-12
- "Resolve Bluetooth Warning: Unable to Read Any Data" on page 16-14
- "Resolve Bluetooth Warning: Unable to Read All Data" on page 16-15

Resolve Bluetooth Connection Errors

Issue

If you are unable to connect to a Bluetooth device using the `bluetooth` interface, follow these troubleshooting steps.

Possible Solutions

MATLAB supports the Bluetooth Serial Port Profile (SPP). You can identify any SPP Bluetooth device and establish a two-way connection with that device.

Configure Adapter

To connect to Bluetooth devices from MATLAB, your computer needs to have a built-in or external Bluetooth adapter. The adapter identifies Bluetooth devices within range when queried. After identifying nearby devices in the Bluetooth settings on your computer, you need to pair your device with your computer first before connecting to it from MATLAB. For more information about discovering and pairing your device, see "Configure Bluetooth Communication Settings" on page 16-3.

If a Bluetooth adapter is removed and a different one plugged in, all Bluetooth devices have to be paired again with your computer. If the same adapter is removed and plugged back in, then you do not need to pair the devices again.

If MATLAB does not detect your built-in or external adapter, restart Bluetooth services on your computer and update to the latest device drivers for your adapter. Then, restart your computer.

Check Device Status

Make sure that the Bluetooth device is turned on and that the Bluetooth service on the device is turned on. Bring the device within range of your computer.

View the status of your device in MATLAB by using the `bluetoothlist` function. You can connect to a device using `bluetooth` only if its status is "Ready to connect". Possible status values follow.

Value	Description
"Ready to connect"	Device supports SPP, is paired, and is not connected anywhere.
"Requires pairing"	Device supports SPP and is not paired.
"Connected"	Device supports SPP and is connected.
"Unsupported"	Device does not support SPP.
"Unknown"	Unknown if device supports SPP. Device is turned off or fails to respond to scanning request.

If your device status is "Unsupported", it does not support SPP. You cannot connect to it from MATLAB.

If your device status is "Unknown", it fails to respond to a scanning request. Make sure that it is within range, turned on, and not already connected outside MATLAB.

If your device does not appear in the `bluetoothlist` output, make sure that it is not connected to any other devices or applications. You can also try a larger value for the `Timeout` parameter in `bluetoothlist`. Using a larger value increases the amount of time MATLAB scans for nearby devices.

For more information about connecting to your device, see “Configure Bluetooth Communication Settings” on page 16-3.

Check Device Connection

Make sure you can connect to the device by creating a `bluetooth` object. You must provide two arguments to create the object, either the device name or address and a channel number. The specified channel number must match the channel number from the `bluetoothlist` output. For more information about creating a `bluetooth` object, see `bluetooth`.

After you connect to the device, you can communicate with it. For more information about communicating with your device, see “Transmit Data Using Bluetooth Communication” on page 16-6.

See Also

`bluetooth`

Related Examples

- “Troubleshooting Bluetooth Communication” on page 16-10

Resolve Bluetooth Warning: Unable to Read Any Data

Issue

These remedies apply when you receive no data and you get this warning message:

```
'bluetooth' unable to read any data.
```

Possible Solutions

Try these remedies to resolve the following causes when you use the Bluetooth interface for:

- Reading ASCII (text) data using the `readline` function.
- Reading binary data using the `read` function.

Cause	Solution
An invalid command was sent to the device, so there is a problem reading the response to the command.	Check your device manual for proper command formatting.
An incorrect write terminator was sent to the instrument before attempting to read data, so there is no data to read.	Verify that the <code>Terminator</code> property is set to the value required by your device. For more information about setting the property, see <code>configureTerminator</code> .
An incorrect device name, address, or channel was used.	Verify that the device is paired and connected. For more information about pairing and connecting, see “Configure Bluetooth Communication Settings” on page 16-3.

See Also

`configureTerminator` | `read` | `readline`

More About

- “Troubleshooting Bluetooth Communication” on page 16-10

Resolve Bluetooth Warning: Unable to Read All Data

Issue

These remedies apply when you receive data and you get this warning message:

```
'bluetooth' unable to read all requested data.
```

Possible Solutions

ASCII Data

Try these remedies to resolve the following causes when you use the Bluetooth interface for reading ASCII (text) data using the `readLine` function.

Cause	Solution
An incorrect read terminator was used.	Verify that the <code>Terminator</code> property is set to the value required by your device. For more information about setting the property, see <code>configureTerminator</code> .
Communication with the device was interrupted.	Check your device connection. For tips, see “Troubleshooting Bluetooth Communication” on page 16-10.

Binary Data

Try these remedies to resolve the following causes when you use the Bluetooth interface for reading binary data using the `read` function.

Cause	Solution
The number of values to read was set to a higher value than the number of values available to be read.	Set the number of values to read using the input argument <code>count</code> on the <code>read</code> function. For information about setting number of values to read, see <code>read</code> .
Device did not send all the requested data.	Check your device connection. For tips, see “Troubleshooting Bluetooth Communication” on page 16-10.
There was a data format mismatch.	Verify that the device data format matches the specified read format. Data format is set using the input argument <code>datatype</code> on the <code>read</code> function. For more information about supported data types, see <code>read</code> .

See Also

`configureTerminator` | `read` | `readLine`

More About

- “Troubleshooting Bluetooth Communication” on page 16-10

Communicate with HC-06 over Bluetooth

This example shows how to communicate with a HC-06 Bluetooth® module using Serial Port Profile.

Hardware Requirements

- Windows® 10 or macOS machine with built-in or external Bluetooth 2.0 compatible adapter
- HC-06 Bluetooth module
- 5 V source, such as an FTDI converter or Arduino® board
- A few wires

Hardware Setup

This example uses a HC-06 Bluetooth transceiver module configured as a loopback device. On the HC-06 module:

- Connect the VCC pin to the 5 V source.
- Connect the GND pin to the ground.
- Connect the TXD pin to the RXD pin.

A blinking LED on the HC-06 module indicates that the device is powered. Next, pair the device on the host computer to allow connection in MATLAB®. The default PIN code is 1234 unless configured otherwise.

Get Device Information

Identify the Bluetooth device address or name and SPP channel number by calling the `bluetoothlist` function. Make sure the device status is "Ready to connect", indicating that it is powered on and paired. If you already know the device information, you can skip this step.

```
bluetoothlist
```

Run `blelist` to search for nearby Bluetooth Low Energy peripheral devices.

```
ans=4x4 table
```

Name	Address	Channel	Status
"HanaBTDev"	"CC78AB79656F"	Unknown	"Unknown"
"EUCLID"	"0016530CE4AC"	Unknown	"Unknown"
"HC-06"	"98D331FB3B77"	1	"Ready to connect"
"DMTDevice"	"B0B448F47A4C"	1	"Requires pairing"

Connect to Device

Use the device address or name and SPP channel number to connect to the device by calling `bluetooth`. Specify the device name if it is unique or specify the device address.

```
hc06 = bluetooth("HC-06", 1)
```

```
hc06 =  
    bluetooth with properties:
```

```

        Name: "HC-06"
        Address: "98D331FB3B77"
        Channel: 1
    NumBytesAvailable: 0
    NumBytesWritten: 0

```

Show all properties

Write and Read Data

After you connect the HC-06 to MATLAB, write byte data or string data to the device by calling `write`.

```

write(hc06, 1:10);
write(hc06, "helloworld");

```

Since the device is configured as a loopback, the data received on the device is immediately returned to MATLAB. Read the data by calling `read`.

```

read(hc06, 10)

```

```

ans = 1×10

```

```

     1     2     3     4     5     6     7     8     9    10

```

```

read(hc06, 10, "string")

```

```

ans =
'helloworld'

```

For information on sending and receiving terminated string data, see `readline` and `writeline`.

Collect Data Asynchronously

You can use a callback function to read data as it is written to the Bluetooth device. Call `configureCallback` to read and collect data each time five bytes are sent by the device and received in MATLAB.

```

function collectData(src, evt)
    % Read received data and store it in the UserData property on the bluetooth object
    src.UserData = [src.UserData; read(src,src.BytesAvailableFcnCount)];
end

```

```

configureCallback(hc06, "byte", 5, @collectData);

```

Write data to the device. The data is immediately sent back to MATLAB, triggering the callback function to read and display the data.

```

write(hc06, 1:20);
% Wait for all callbacks to be processed
pause(1);
disp(hc06.UserData);

```

```

     1     2     3     4     5
     6     7     8     9    10
    11    12    13    14    15
    16    17    18    19    20

```

Disconnect from Device

Clear the device object when you are finished working with it.

```
clear hc06
```

Transition Your Code to bluetooth Interface

A new set of MATLAB functions and properties provides support for communicating with Bluetooth devices. The `Bluetooth` function, its object functions, and its properties will be removed. Use the `bluetooth` (case-sensitive) interface instead.

Bluetooth Interface	bluetooth Interface	Example
<code>instrhwinfo</code>	<code>bluetoothlist</code>	"Discover Bluetooth Devices" on page 16-20
Bluetooth and <code>fopen</code>	<code>bluetooth</code>	"Connect to Bluetooth Device" on page 16-20
<code>fwrite</code>	<code>write</code>	"Write and Read" on page 16-20
<code>fread</code>	<code>read</code>	
<code>fprintf</code>	<code>writeline</code>	"Send Command" on page 16-22
		"Write and Read Back Data" on page 16-23
<code>fscanf</code>	<code>readline</code>	"Read Terminated String" on page 16-21
<code>fgetl</code>		"Write and Read Back Data" on page 16-23
<code>fgets</code>		"Read and Parse String Data" on page 16-23
<code>flushinput</code> and <code>flushoutput</code>	<code>flush</code>	"Flush Data from Memory" on page 16-23
Terminator	<code>configureTerminator</code>	"Set Terminator" on page 16-24
<code>BytesAvailableFcnCount</code> , <code>BytesAvailableFcnMode</code> , and <code>BytesAvailableFcn</code>	<code>configureCallback</code>	"Set Up Callback Function" on page 16-24
<code>BytesAvailable</code>	<code>NumBytesAvailable</code>	
<code>RemoteName</code>	<code>Name</code>	
<code>RemoteID</code>	<code>Address</code>	
<code>ErrorFcn</code>	<code>ErrorOccurredFcn</code>	

Removed Functionality

The `binblockread` and `binblockwrite` functions will be removed.

The `ValuesReceived` and `ValuesSent` properties will be removed. You can calculate the number of values sent using the `NumBytesAvailable` property and the data type of the data available. For example, if the `NumBytesAvailable` is 20 bytes of `uint32` data, the number of values sent is five since each `uint32` value is four bytes.

The `readasync` and `stopasync` functions and the `ReadAsyncMode` and `TransferStatus` properties will be removed. The updated interface reads data asynchronously.

The `BytesToOutput`, `InputBufferSize`, and `OutputBufferSize` properties will be removed. Buffer sizes are automatically managed and sized as needed.

The `OutputEmptyFcn` property is not available in the updated interface. You can set callback functions using `configureCallback` in the updated interface, but not for this property.

The `RecordDetail`, `RecordMode`, `RecordName`, and `RecordStatus` properties will be removed.

The `TimerFcn` and `TimerPeriod` properties will be removed. Use `timer` instead.

The `Profile`, `ObjectVisibility`, `Status`, and `Tag` properties will be removed.

Discover Bluetooth Devices

This example shows how to discover Bluetooth devices using the recommended functionality.

Functionality	Use This Instead
<code>instrhwinfo('Bluetooth')</code>	<code>bluetoothlist</code>

For more information, see `bluetoothlist`.

Connect to Bluetooth Device

These examples show how to connect to a Bluetooth device and disconnect from it using the recommended functionality.

Functionality	Use This Instead
<code>b = Bluetooth('NXT',3)</code> <code>fopen(b)</code>	<code>b = bluetooth("NXT",3)</code>
<code>fclose(b)</code> <code>delete(b)</code> <code>clear b</code>	<code>clear b</code>

The `fopen` function is not available in the updated interface. The object creation function `bluetooth` both creates the object and connects the object to the device.

The `fclose` function is not available in the updated interface. The `clear` function disconnects the object from the device when it removes the object from the workspace.

For more information, see `bluetooth`.

Write and Read

These examples use a loopback device to show how to perform a binary write and read, write nonterminated string data, and read fixed-length string data using the recommended functionality.

Functionality	Use This Instead
<pre>% b is a Bluetooth object fwrite(b,1:5) data = fread(b,5) data = 1 2 3 4 5</pre>	<pre>% b is a bluetooth object write(b,1:5) data = read(b,5) data = 1 2 3 4 5</pre>
<pre>% b is a Bluetooth object command = "start"; fwrite(b,command,"char")</pre>	<pre>% b is a bluetooth object command = "start"; write(b,command,"char")</pre>
	<pre>% b is a bluetooth object command = "start"; write(b,command,"string")</pre>
<pre>% b is a Bluetooth object length = 5; data = fread(b,length,"char") resp = 104 101 108 108 111 data = char(data) ' resp = 'hello'</pre>	<pre>% b is a bluetooth object length = 5; data = read(b,length,"string") data = "hello"</pre>

For more information, see `write` or `read`.

Read Terminated String

These examples show how to perform a terminated string read using the recommended functionality.

Functionality	Use This Instead
<p><code>% b is a Bluetooth object</code> <code>data = fscanf(b, "%e")</code></p> <pre>data = 11.9000</pre> <p>For the format specifier "%e", fscanf returns the terminator and the user must remove it from the string.</p>	<p><code>% b is a bluetooth object</code> <code>data = readline(b)</code></p> <pre>data = "11.9"</pre> <p><code>data = sscanf(data, "%e")</code></p> <pre>data = 11.9000</pre>
<p><code>% b is a Bluetooth object</code> <code>data = fgetl(b)</code></p> <pre>data = 'hello'</pre> <p>fgetl reads until the specified terminator is reached and then discards the terminator.</p>	<p><code>% b is a bluetooth object</code> <code>data = readline(b)</code></p> <pre>data = "hello"</pre> <p>readline reads until the specified terminator is reached and then discards the terminator. There is no option to include the terminator.</p>
<p><code>% b is a Bluetooth object</code> <code>data = fgets(b)</code></p> <pre>data = 'hello '</pre> <p>fgets reads until the specified terminator is reached and then returns the terminator.</p>	

For more information, see `readline`.

Send Command

This example shows how to write terminated string data using the recommended functionality.

Functionality	Use This Instead
<p><code>% b is a Bluetooth object</code> <code>b.Terminator = "CR/LF"</code> <code>channel = 1;</code> <code>fprintf(b, "id is %d", channel);</code></p>	<p><code>% b is a bluetooth object</code> <code>configureTerminator(b, "CR/LF")</code> <code>channel = 1;</code> <code>str = sprintf("id is %d", channel);</code> <code>writeline(b, str)</code></p> <p>writeline automatically appends the write terminator.</p>

For more information, see `configureTerminator` or `writeline`.

Write and Read Back Data

This example shows how to write text and read back data using the recommended functionality.

Functionality	Use This Instead
<pre>% b is a Bluetooth object data = query(b, 'ctrlcmd') data = 'success'</pre>	<pre>% b is a bluetooth object writeline(b, "ctrlcmd") data = readline(b) data = "success"</pre>

For more information, see `writeline` or `readline`.

Read and Parse String Data

This example shows how to read and parse string data using the recommended functionality.

Functionality	Use This Instead
<pre>% b is a Bluetooth object data = scanstr(b, ';') data = 3x1 cell array {'a'} {'b'} {'c'}</pre>	<pre>% b is a bluetooth object data = readline(b) data = "a;b;c" data = strsplit(data, ";") data = 1x3 string array "a" "b" "c"</pre>

For more information, see `readline`.

Flush Data from Memory

This example shows how to flush data from the buffer using the recommended functionality.

Functionality	Use This Instead
<pre>% b is a Bluetooth object flushinput(b)</pre>	<pre>% b is a bluetooth object flush(b, "input")</pre>
<pre>% b is a Bluetooth object flushoutput(b)</pre>	<pre>% b is a bluetooth object flush(b, "output")</pre>
<pre>% b is a Bluetooth object flushinput(b) flushoutput(b)</pre>	<pre>% b is a bluetooth object flush(b)</pre>

For more information, see `flush`.

Set Terminator

This example shows how to set the terminator using the recommended functionality.

Functionality	Use This Instead
<pre>% b is a Bluetooth object b.Terminator = "CR/LF";</pre>	<pre>% b is a bluetooth object configureTerminator(b,"CR/LF")</pre>
<pre>% b is a Bluetooth object b.Terminator = {"CR/LF" [10]};</pre>	<pre>% b is a bluetooth object configureTerminator(b,"CR/LF",10)</pre>

For more information, see `configureTerminator`.

Set Up Callback Function

This example uses a loopback device to show how to set up a callback function using the recommended functionality.

Functionality	Use This Instead
<pre>% b is a Bluetooth object b.BytesAvailableFcnCount = 5 b.BytesAvailableFcnMode = "byte" b.BytesAvailableFcn = @mycallback function mycallback(src,evt) data = fread(src,src.BytesAvailableFcnCount); disp(evt) disp(evt.Data) end Type: 'BytesAvailable' Data: [1x1 struct] AbsTime: [2019 12 21 16 35 9.7032]</pre>	<pre>% b is a bluetooth object configureCallback(b,"byte",5,@mycallback); function mycallback(src,evt) data = read(src,src.BytesAvailableFcnCount); disp(evt) ByteAvailableInfo with properties: BytesAvailableFcnCount: 5 AbsTime: 21-Dec-2019 12:23:01</pre>
<pre>% b is a Bluetooth object b.Terminator = "LF/CR" b.BytesAvailableFcnMode = "terminator" b.BytesAvailableFcn = @mycallback function mycallback(src,evt) data = fscanf(src,'%s'); disp(evt) disp(evt.Data) end Type: 'BytesAvailable' Data: [1x1 struct] AbsTime: [2019 12 21 16 35 9.7032]</pre>	<pre>% b is a bluetooth object configureTerminator(b,"LF/CR") configureCallback(b,"terminator",@mycallback); function mycallback(src,evt) data = readline(src); disp(evt) end TerminatorAvailableInfo with properties: AbsTime: 21-Dec-2019 12:23:01</pre>

For more information, see `configureCallback`.

See Also

[bluetoothlist](#) | [bluetooth](#)

More About

- [R2020a Bluetooth Communication Topics](#)

Hardware Manager

Get Started with Hardware Manager

In this section...

“Discover Hardware” on page 17-2

“Add Hardware” on page 17-4

Hardware Manager is a graphical interface that allows you to discover and connect to your hardware from MATLAB by providing access to the necessary add-ons and apps.

Discover Hardware

When you open **Hardware Manager**, it displays all applicable hardware devices, channels, and protocols detected on your system. To access your hardware, follow these steps:

- 1 Open **Hardware Manager**, either by clicking it in the apps gallery, or by typing

```
hardwareManager
```

Hardware Manager displays all the applicable detected hardware connected to your system. Allow a moment for the list to be completed. When ready, **Hardware Manager** might look like this:

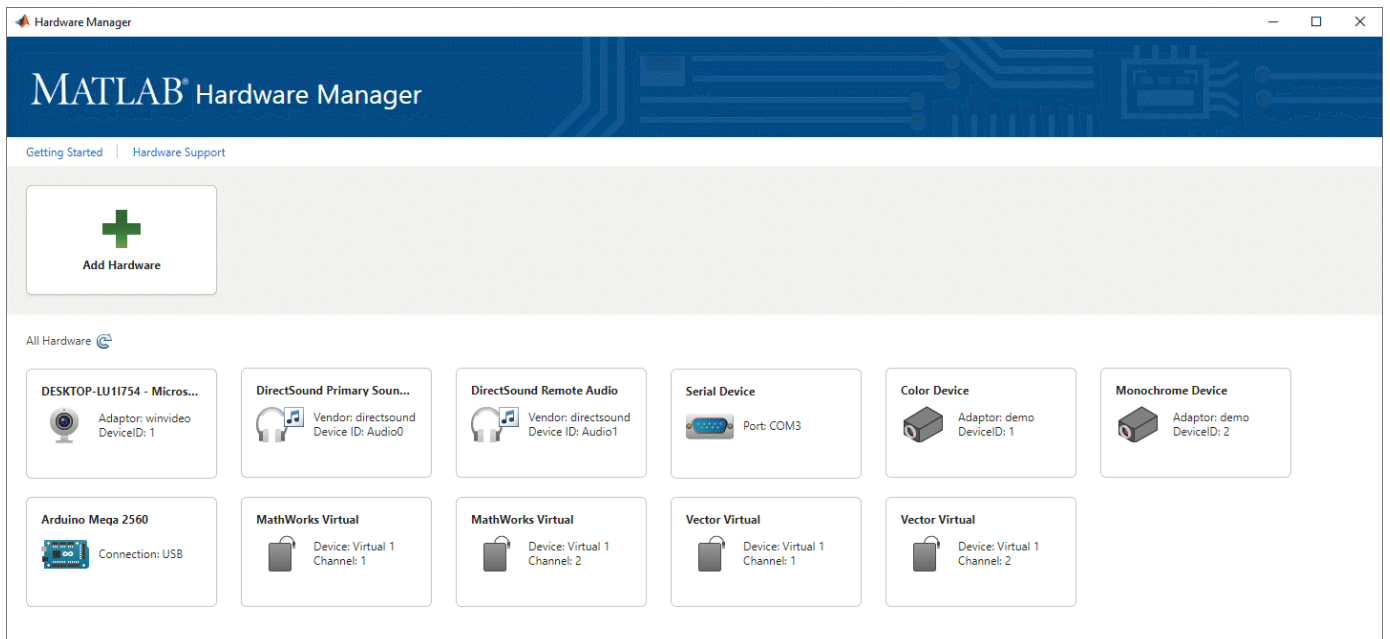

If you do not see your hardware listed in your display, see “Add Hardware” on page 17-4.

- 2 Click the device you want to use.

Hardware manager displays a list of apps that support your device. For example, if you select a serial port, the **Serial Explorer** app is available.

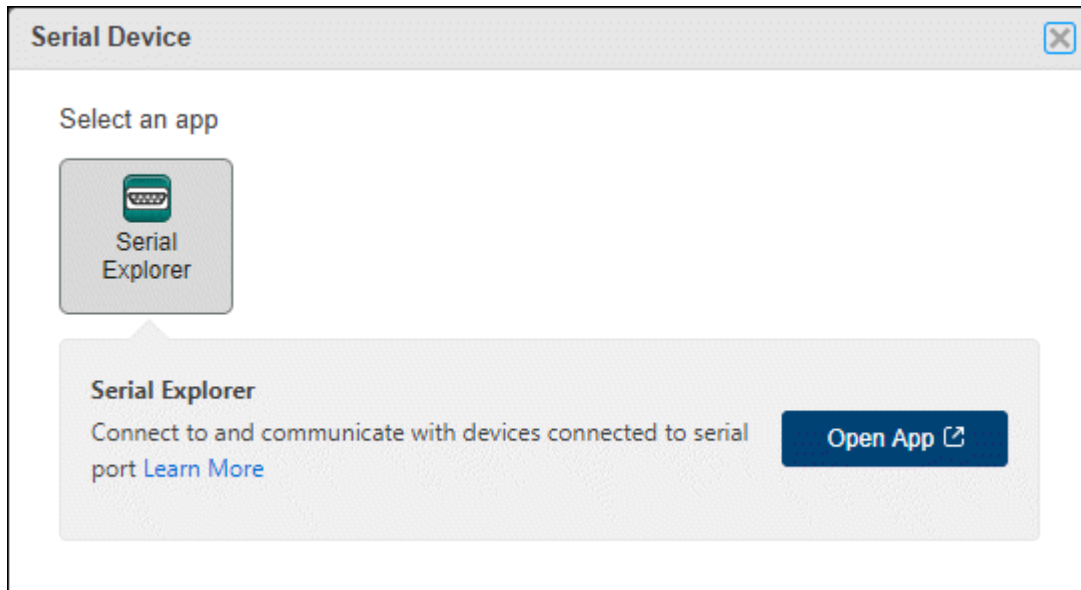

For this particular device, no add-ons are needed. So you can directly open the **Serial Explorer** app.

If the app you want to use with your device is available in an add-on that you do not have installed, **Hardware Manager** provides a link so you can install the necessary product or support package. For example, if you select a Vector Virtual 1 device and want to use the **CAN Explorer** app, this requires Vehicle Network Toolbox and an additional support package. If you have the toolbox installed, but not the support package, **Hardware Manager** indicates that installation is required:

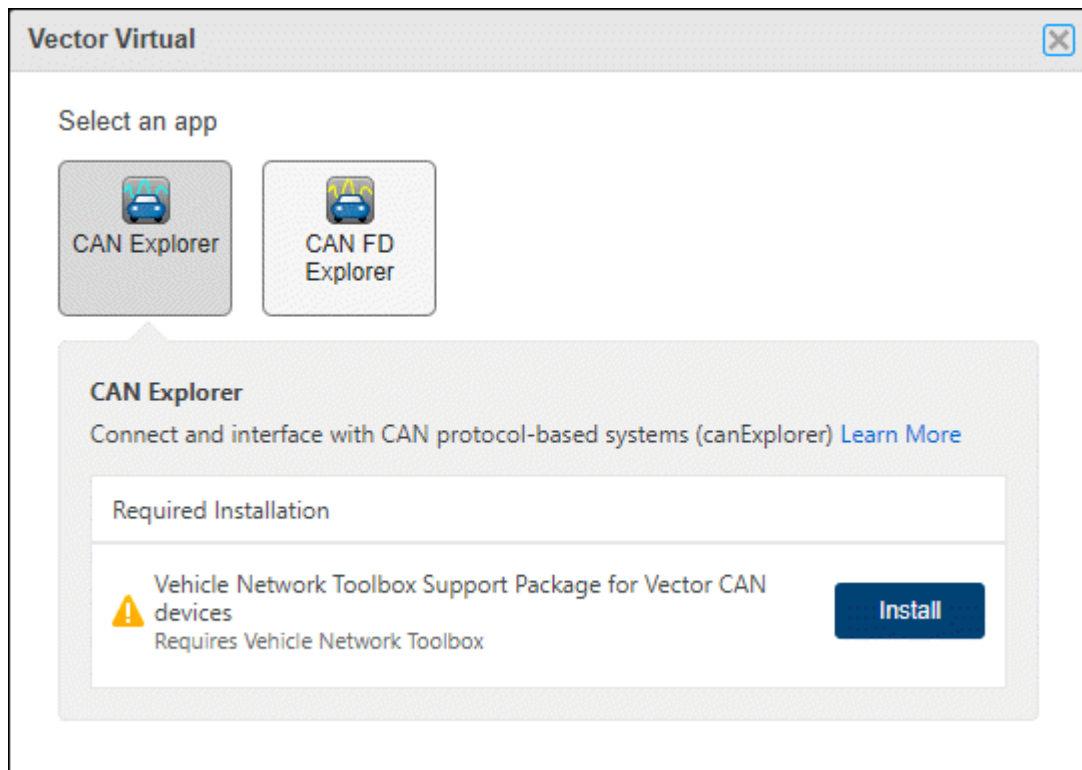

Add Hardware

In some cases, **Hardware Manager** might not automatically detect or recognize your hardware. This can happen for devices that require add-ons to be installed before detection can occur. You can manually add and configure your device, following these steps.

- 1 Click **Add Hardware**.
- 2 Select a hardware type and interface/protocol for communicating with your hardware. Among the choices are Arduino®, Raspberry Pi™, CAN, TCP/IP, and so on.
- 3 Select a manufacturer. Whether you need to select a manufacturer and which ones you can choose depend on the hardware type you chose. Some of the supported vendors are NI™, Analog Devices®, Kvaser, and so on.

For your selections, **Hardware Manager** displays the apps that are applicable and indicates which MathWorks® products to install.

Example 17.1. Connect a DCAM-Compliant Camera

For example, suppose you want to connect MATLAB to a DCAM-compliant digital camera in **Hardware Manager**.

Click **Add Hardware**.

For **Hardware type/interface**, choose **Cameras and Frame Grabbers**.

For **Select your hardware manufacturer**, choose **DCAM**. This is not actually a manufacturer, but is an industry-standard class of camera.

Your Add Hardware dialog might look like this:

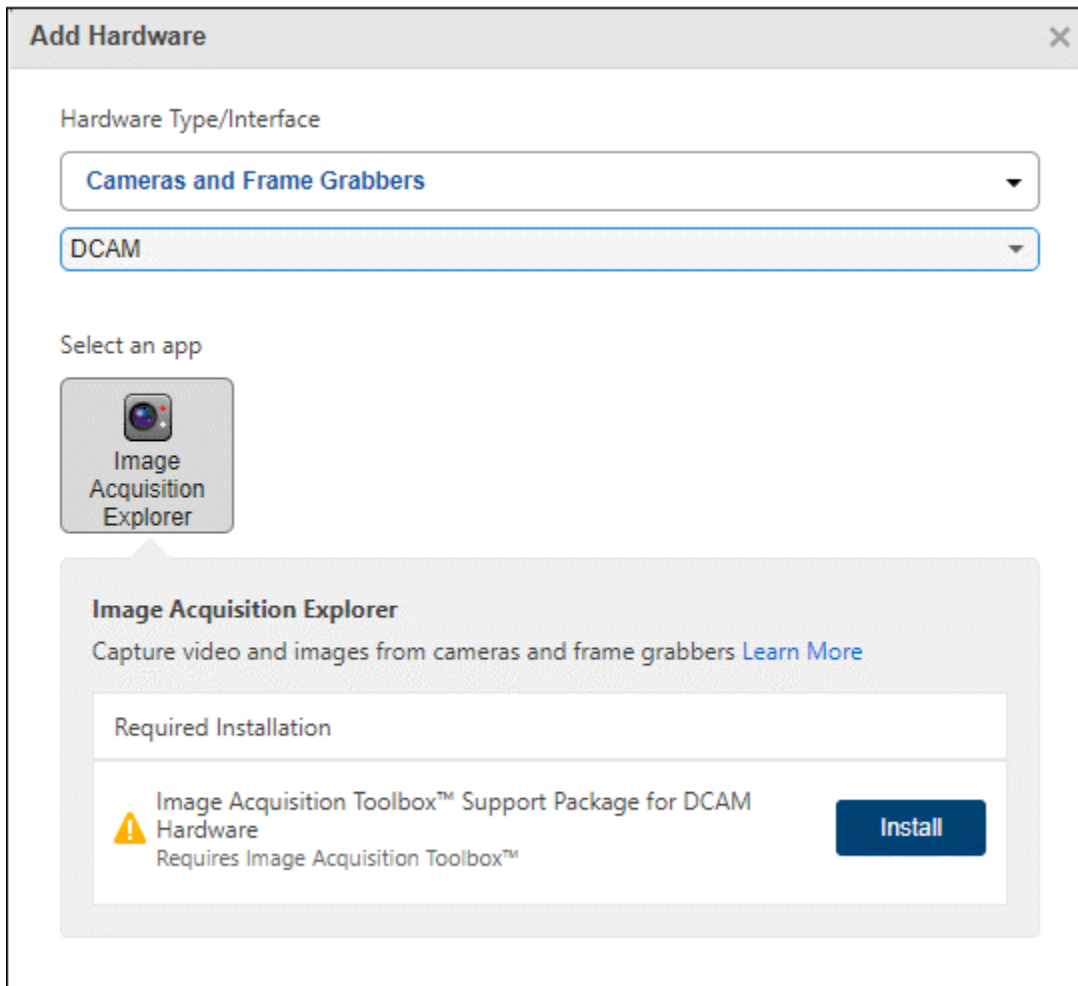

In this example, the **Image Acquisition Explorer** app is provided in Image Acquisition Toolbox™. This toolbox is already installed, so **Hardware Manager** does not prompt you to do that. However, the chosen camera type of DCAM requires a support package which is not installed. At this point, you can click **Install** to get the required support package.

See Also

Apps
Hardware Manager

